

Automatic Transmission Mechanical and Hydraulic Systems Phase 2



SAFETY NOTICE

This publication's purpose is to provide technical training information to individuals in the automotive trade. All test and repair procedures must be performed in accordance with manufacturer's service and diagnostic manuals. All **warnings**, **cautions**, and **notes** must be observed for safety reasons. The following is a list of general guidelines:

- Proper service and repair is critical to the safe, reliable operation of all motor vehicles.
- The information in this publication has been developed for service personnel, and can help when diagnosing and performing vehicle repairs.
- Some service procedures require the use of special tools. These special tools must be used as recommended throughout this Technical Training Publication, the diagnostic manual, and the service manual.
- Special attention should be exercised when working with spring- or tension-loaded fasteners and devices such as E-Clips, Cir-clips, snap rings, etc. Careless removal may cause personal injury.
- Always wear safety goggles when working on vehicles or vehicle components.
- Improper service methods may damage the vehicle or render it unsafe.
- Observe all **warnings** to avoid the risk of personal injury.
- Observe all **cautions** to avoid damage to equipment and vehicles.
- **Notes** are intended to add clarity and should help make your job easier.

Cautions and **warnings** cover only the situations and procedures FCA US LLC has encountered and recommended. Neither FCA US LLC nor its subsidiaries or affiliates cannot know, evaluate, and advise the service trade of all conceivable ways in which service may be performed, or of the possible hazards for each. Consequently, FCA US LLC and its subsidiaries and affiliates have not undertaken any such broad service review. Accordingly, anyone who used a service procedure or tool that is not recommended in this publication, must be certain that neither personal safety, nor vehicle safety, is jeopardized by the service methods they select.

No part of this publication may be reproduced, stored in a retrieval system or transmitted, in any form or by any means, electronic, mechanical, photocopying, recording, or otherwise, without the prior written permission of FCA US LLC.

FCA US LLC reserves the right to make changes from time to time, without notice or obligation, in prices, specifications, colors and materials, and to change or discontinue models. See your dealer for the latest information.

Copyright © 2016 FCA US LLC





TABLE OF CONTENTS

INTRODUCTION	1
COURSE OBJECTIVES	1
ACRONYMS	2
LESSON 1 FLUID LEAKS	5
FLUID LEAK IDENTIFICATION	5
Fluid Leak Inspection Tools	5
Fluid Leak Inspection Methods.....	6
EXTERNAL SEALS.....	7
Lip Seal Locations	7
Case Housing Seals	8
Directional Seals.....	9
Differential Seals	10
Gaskets.....	11
Gasket Locations	11
Reusable Gaskets	12
Chemical Sealers.....	13
RTV Sealer Application	14
CASTING POROSITY.....	15
Case Porosity	15
Pump Porosity.....	16
Fluid Connections	17
Cooler Line Fitting Seal	18
VENT ASSEMBLY LEAKS	19
Over-Filled	19
Over-Heating	19
Internal Vent Circuit Leak.....	19
BELLHOUSING LEAKS.....	20
DEMONSTRATION 1 LEAK LOCATIONS AND DIAGNOSTIC TOOLS (62TE BENCH UNIT)	23
ACTIVITY 1 LEAK DIAGNOSIS	25
TASK ONE: ON-VEHICLE FLUID DYE LEAK INSPECTION	25
TASK TWO: ON-BENCH TRACING POWDER INSPECTION	27
LESSON 2 TORQUE CONVERTER AND TEMPERATURE CONTROL	31
TORQUE CONVERTER COMPONENTS	31
Impeller Assembly.....	32
Turbine Assembly	33

Stator Assembly	34
Torque Converter Clutch (TCC) Assembly	35
Torque Converter Fluid Flow.....	36
TORQUE CONVERTER MECHANICAL OPERATION	37
Stator Operation.....	38
TORQUE CONVERTER HYDRAULIC OPERATION	39
Torque Converter Pressure Regulation	39
Converter Control Switch Valve	40
Converter Control Switch Valve (continued).....	41
TORQUE CONVERTER CLUTCH (TCC) MECHANICAL OPERATION	42
TORQUE CONVERTER CLUTCH (TCC) HYDRAULIC OPERATION.....	43
Two-Channel TCC Control Circuit	43
Three-Channel TCC Control Circuit.....	44
TORQUE CONVERTER NOISE DIAGNOSIS.....	45
Torque Converter External Noise	45
Torque Converter Internal Noise - Park or Neutral.....	46
Torque Converter Internal Noise - Drive or Reverse	47
Torque Converter Internal Noise - Cruise.....	48
Torque Converter Internal Noise and Vibration - TCC Apply	49
TRANSMISSION COOLING SYSTEM.....	50
Single-Pass Parallel-Path Coolers.....	51
Bolt-on-Cooler.....	52
Oil-to-Air Cooler.....	53
Double-Pass Parallel-Path Design	53
Double-Pass Combination Cooler	54
Double-Pass Stand-Alone Cooler	54
COOLING SYSTEM HYDRAULIC OPERATION.....	55
Pressure Bypass Systems	55
Thermal and Pressure Bypass Systems.....	57
Thermal Bypass Valve Tube Type	61
TRANSMISSION OIL HEATER SYSTEM.....	62
Coolant Bypass Valve	63
DEMONSTRATION 2 TORQUE CONVERTER COMPONENTS.....	65
ACTIVITY 2 TORQUE CONVERTER MECHANICAL DIAGNOSIS	69
TASK ONE: SLUGGISH VEHICLE LAUNCH	69
TASK TWO: POOR VEHICLE PERFORMANCE AFTER LAUNCH.....	73
TASK THREE: POOR FUEL ECONOMY.....	75
ACTIVITY 3 TORQUE CONVERTER HYDRAULIC DIAGNOSIS.....	79

TASK ONE: RFE DELAYED ENGAGEMENT DURING COLD STARTS	79
ACTIVITY 4 TORQUE CONVERTER NOISE DIAGNOSIS	83
LESSON 3 DIAGNOSTIC MEASUREMENTS AND TESTS	89
PURPOSE OF TESTING	89
TRANSMISSION LINE PRESSURE CHECK	90
CLUTCH AIR CHECKS	91
ENDPLAY MEASUREMENTS	92
DEMONSTRATION 3 LINE PRESSURE CHECK	95
ACTIVITY 5 ENDPLAY CHECK	97
ACTIVITY 6 VALVE BODY REMOVAL AND AIR CHECK	99
LESSON 4 FLUID PUMP	107
FLUID PUMP MECHANICAL OPERATION	107
General Operation	107
Crescent Gear Pumps	108
Gerotor Pumps	109
Dual Stage Pumps	110
Pump Body Valves	111
Chain Drive Oil Pump	112
Vane Style Oil Pump	113
FLUID PUMP HYDRAULIC OPERATION	114
Closed-Loop Line Pressure Control	114
Default Line Pressure Control	115
Open-Loop Line Pressure Control	116
FLUID PUMP NOISE DIAGNOSIS	117
Fluid Pump Noise	117
ACTIVITY 7 PUMP REMOVAL	119
DEMONSTRATION 4 FLUID PUMP COMPONENTS	123
ACTIVITY 8 FLUID PUMP MECHANICAL DIAGNOSIS	127
TASK ONE: SLOW ENGAGEMENT INTO REVERSE AND DRIVE	127
ACTIVITY 9 FLUID PUMP HYDRAULIC DIAGNOSIS	131
TASK ONE: TRANSMISSION HAS SLOW ENGAGEMENTS AND SOFT SHIFTS IN ALL GEARS	131
TASK TWO: TRANSMISSION HAS HARSH ENGAGEMENTS AND HARSH SHIFTS IN ALL GEARS	135
ACTIVITY 10 FLUID PUMP NOISE DIAGNOSIS	139
LESSON 5 GEARSETS	141
PLANETARY GEARSETS	141
Simple Planetary Gearset	141
Simpson Planetary Gearset	142

Ravigneaux Planetary Gearset	143
Compounded Planetary Gearset.....	144
PLANETARY GEARSET POWERFLOW.....	145
Calculating Gear Ratio	146
Gear Reduction	147
Direct Drive	148
Overdrive.....	149
Reverse	150
GEARSET LUBRICATION	152
Lubrication Passages	152
PARKING SYSTEMS	154
Parking System Components.....	154
Parking System Operation	155
Park Lock System.....	156
FINAL DRIVE SYSTEMS	157
Final Drive Components	158
62TE Transfer Gears.....	159
GEARSET/ROTATING ASSEMBLY NOISE	160
Input Component Noise.....	161
Output Component Noise	162
Gearset Noise.....	163
Final Drive Noise	164
ACTIVITY 11 TRANSMISSION DISASSEMBLY.....	167
DEMONSTRATION 5 CLUTCH APPLICATION CHART	185
ACTIVITY 12 CLUTCH AND GEARSET INTERACTION	191
TASK ONE: UNDERDRIVE POWERFLOW.....	191
TASK TWO: DIRECT DRIVE POWERFLOW	199
TASK THREE: OVERDRIVE POWERFLOW.....	202
ACTIVITY 13 GEARSET MECHANICAL DIAGNOSIS.....	207
ACTIVITY 14 GEARSET HYDRAULIC/LUBRICATION DIAGNOSIS	209
ACTIVITY 15 GEARSET NOISE DIAGNOSIS	215
LESSON 6 CLUTCH ELEMENTS.....	221
CLUTCH ELEMENTS	221
CLUTCH AND SOLENOID APPLICATION CHARTS	223
Clutch Application Charts.....	223
Solenoid Application Charts.....	224
HYDRAULIC CONTROLS.....	226
Solenoids.....	227

Check Balls	228
Spool Valves	229
Accumulators.....	230
Manual Valve	231
Non-Manual Valve	232
Limp Modes	234
Limp Modes Examples	235
CLUTCH OPERATION.....	236
Multi-Disc Clutch Operation.....	236
MULTI-DISC CLUTCH.....	238
Multi-Disc Clutch Components	238
OVERRUNNING CLUTCHES.....	243
Roller-Type.....	243
Sprag-Type	244
DOG CLUTCHES.....	245
CLUTCH LUBRICATION.....	246
Lubrication Passages	246
NOISE	247
CLUTCH NOISE	247
DEMONSTRATION 6 SOLENOID APPLICATION CHART.....	251
ACTIVITY 16 CLUTCH HYDRAULIC DIAGNOSIS.....	255
ACTIVITY 17 CLUTCH MECHANICAL DIAGNOSIS	267
ACTIVITY 18 CLUTCH NOISE DIAGNOSIS.....	269
ACTIVITY 19 TRANSMISSION ASSEMBLY	273
APPENDIX	295
GLOSSARY	303

INTRODUCTION

This course is intended to provide the entry level automatic transmission technician with the skills necessary to successfully diagnose the mechanical and hydraulic automatic transmission control systems on the first visit.

COURSE OBJECTIVES

After completing this course, the technician will be able to:

- Diagnose and identify repairs for transmission fluid leaks
- Diagnose torque converter operation for mechanical, hydraulic, and noise concerns
- Diagnose thermal management systems for mechanical and hydraulic concerns
- Perform initial diagnostic measurements and tests, including line pressure, endplay check, and clutch air checks
- Diagnose oil pump operation and pressure regulation for mechanical, hydraulic, and noise concerns
- Use clutch application charts to diagnose gearset mechanical and noise concerns and diagnose the lubrication system
- Diagnose clutch operation for mechanical, hydraulic, and noise concerns

ACRONYMS

The following is a list of acronyms used throughout this publication:

CVI	Clutch Volume Index
DLC	Data Link Connector
DTC	Diagnostic Trouble Code
DMM	Digital MultiMeter
DC	Direct Clutch
ERS	Electronic Range Select
EMCC	Electronically-Modulated Converter Clutch
ECT	Engine Coolant Temperature
LC	Low Clutch
LR/CC	Low Reverse/Converter Clutch
L/R	Low/Reverse
MIL	Malfunction Indicator Lamp
MAP	Manifold Absolute Pressure
OD	Overdrive
PCM	Powertrain Control Module
PWM	Pulse-Width-Modulated
RFE	Rear Fully Electronic (545RFE/65RFE/66RFE/68RFE)
rpm	Revolutions Per Minute
RTV	Room Temperature Vulcanizing
SLA	Shift Lever Assembly
SLP	Shift Lever Position
SAE	Society of Automotive Engineers
SSV	Solenoid Switch Valve
TPS	Throttle Position Sensor
TCC	Torque Converter Clutch
TCM	Transmission Control Module
TCR	Transmission Control Relay
TRS	Transmission Range Sensor
TTS	Transmission Temperature Sensor
TE	Transverse Electronic (62TE)
UD	Underdrive
VFS	Variable Force Solenoid
VLP	Variable Line Pressure
VIN	Vehicle Identification Number
WOT	Wide-Open Throttle

Notes: _____

LESSON 1 FLUID LEAKS

FLUID LEAK IDENTIFICATION

Fluid Leak Inspection Tools

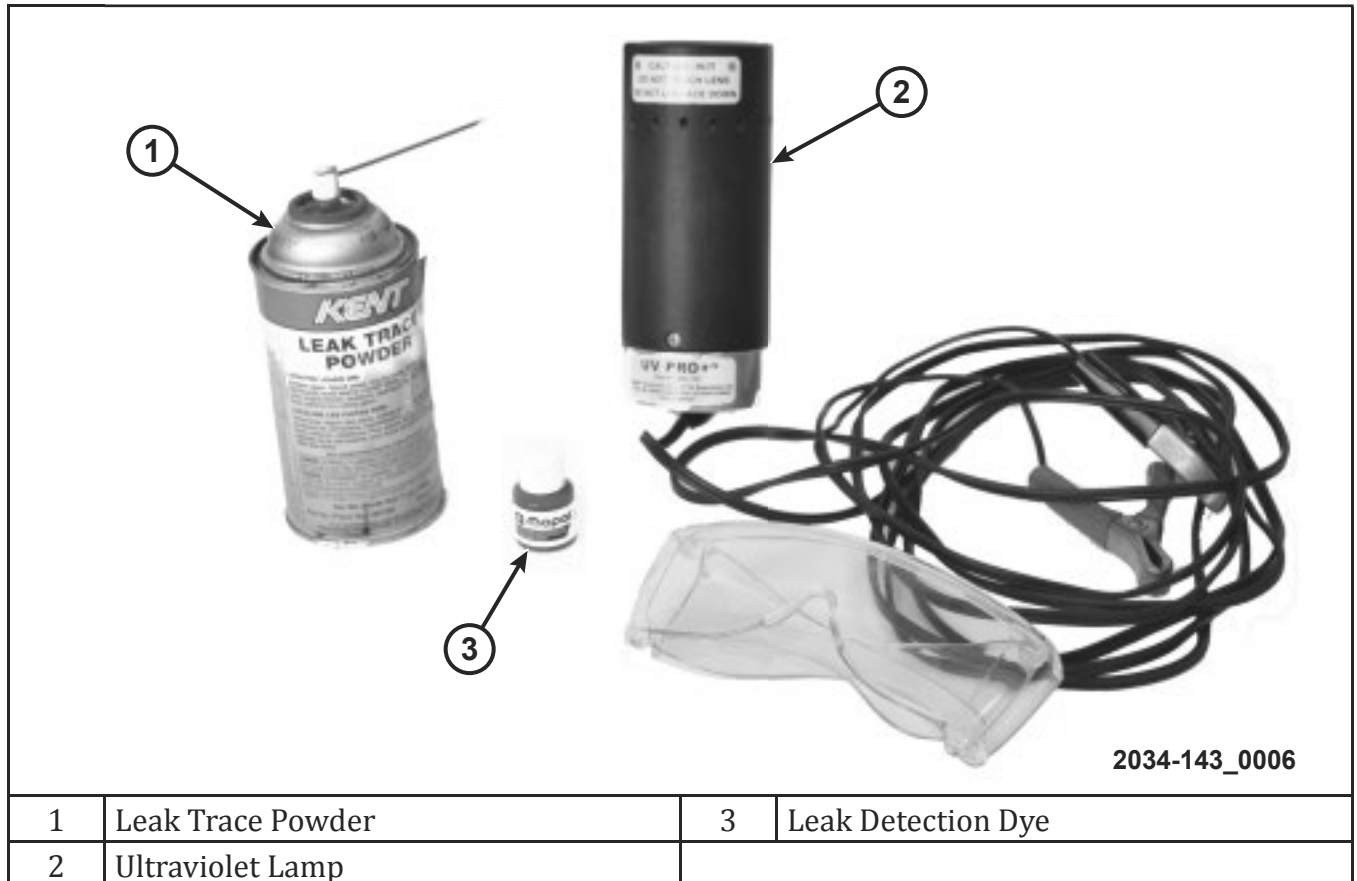

Figure 1 Leak Inspection Tools

Visual inspections include the following:

- Clean the residual fluid
- Apply leak detection dye or leak trace powder
- Duplicate the leak
- Isolate the leak concern

Fluid Leaks

Fluid Leak Inspection Methods

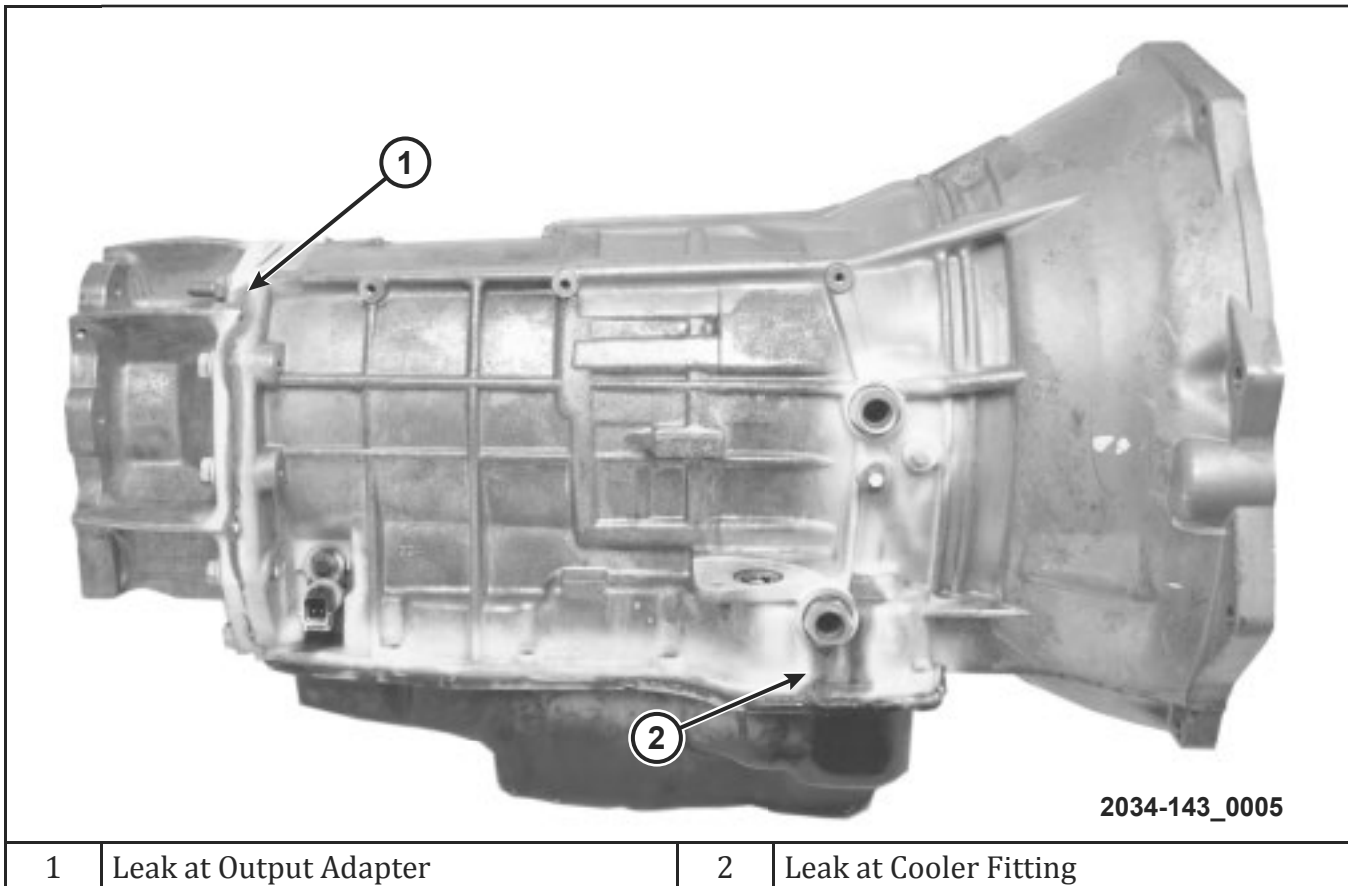

Figure 2 Fluid Leak

Gravity pulls fluid down, so it is important to trace the leak back to the highest point that fluid is visible. To duplicate the leak, some concerns may require operating the vehicle under specific conditions, such as:

- High operating temperatures
- High vehicle loads
- Driving on an incline or decline
- Specific gear ranges

EXTERNAL SEALS

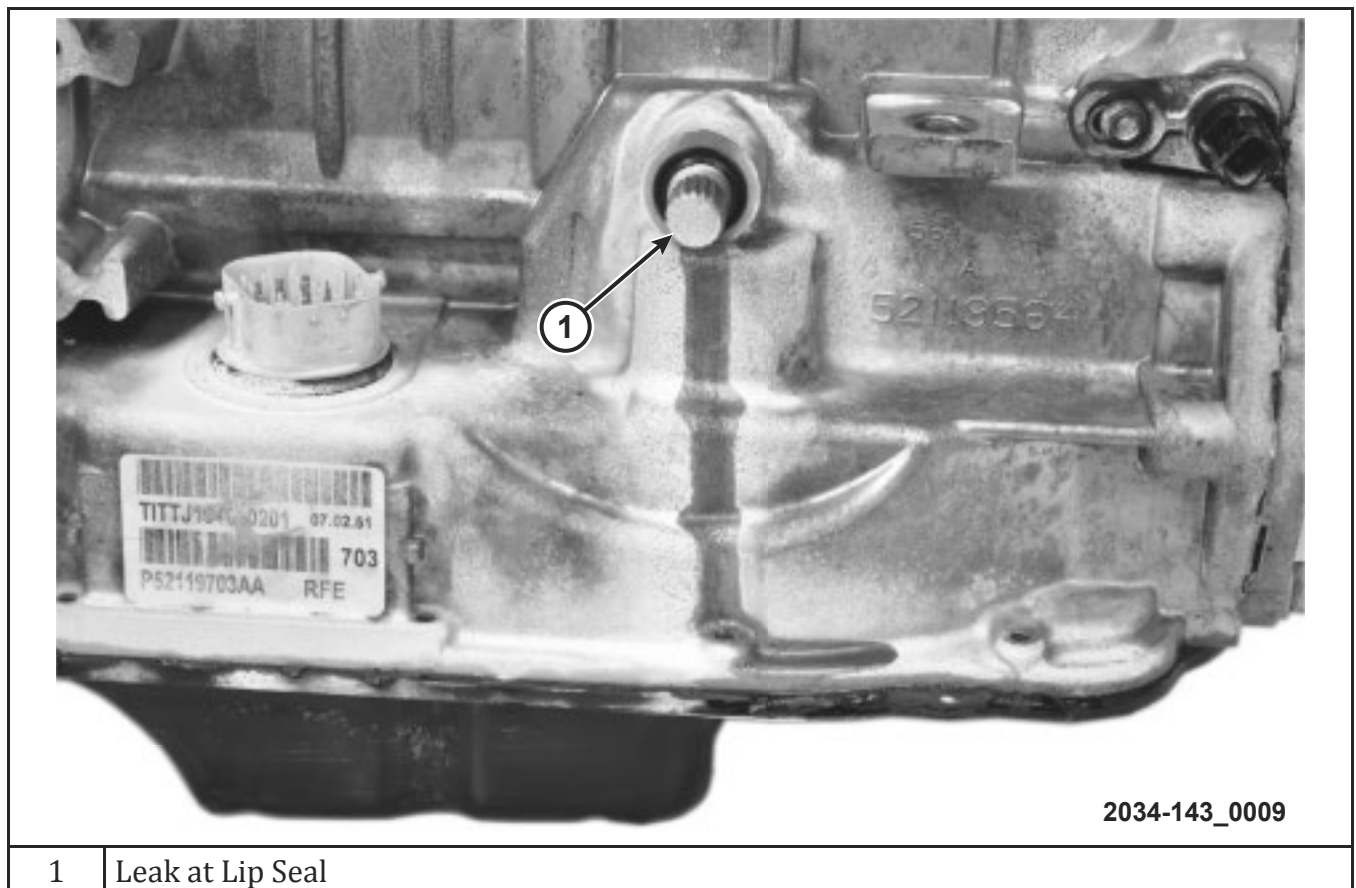

Figure 3 Shifter Shaft Lip Seal Leak

Lip Seal Locations

Lip seals are found in automatic transmissions anywhere a shaft needs to rotate and extend outside the transmission.

Lip seals are used in the following external locations on most transmissions:

- Torque converter hub seal
- Shifter shaft seal
- Output shaft seals on rear-wheel drive transmissions
- Half-shaft seals on transaxles

Lip seals can leak on the lip area as well as the outside of the seal where it meets the mounting bore. It is important to inspect both sealing surfaces for imperfections when replacing a lip seal.

Case Housing Seals

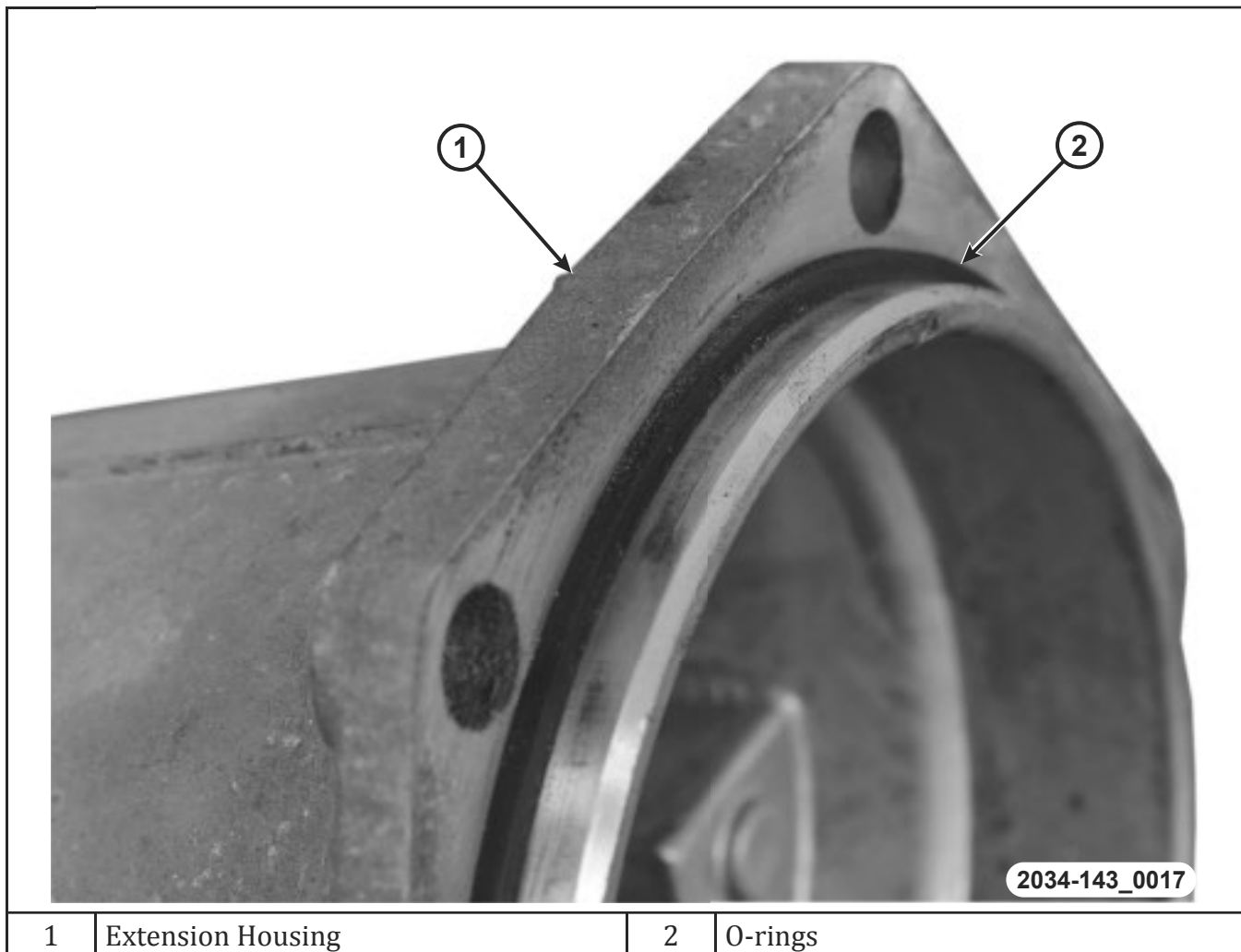

Figure 4 Seal

O-ring or square-cut seals are used in many transmission applications. These seals are usually round or square in cross-section, but ovals are used occasionally as well.

These seals are used in the following external locations on most transmissions:

- Extension housing
- Oil pump housing
- Speed sensors
- Shifter shaft seal
- Electrical pass-through connector

Directional Seals

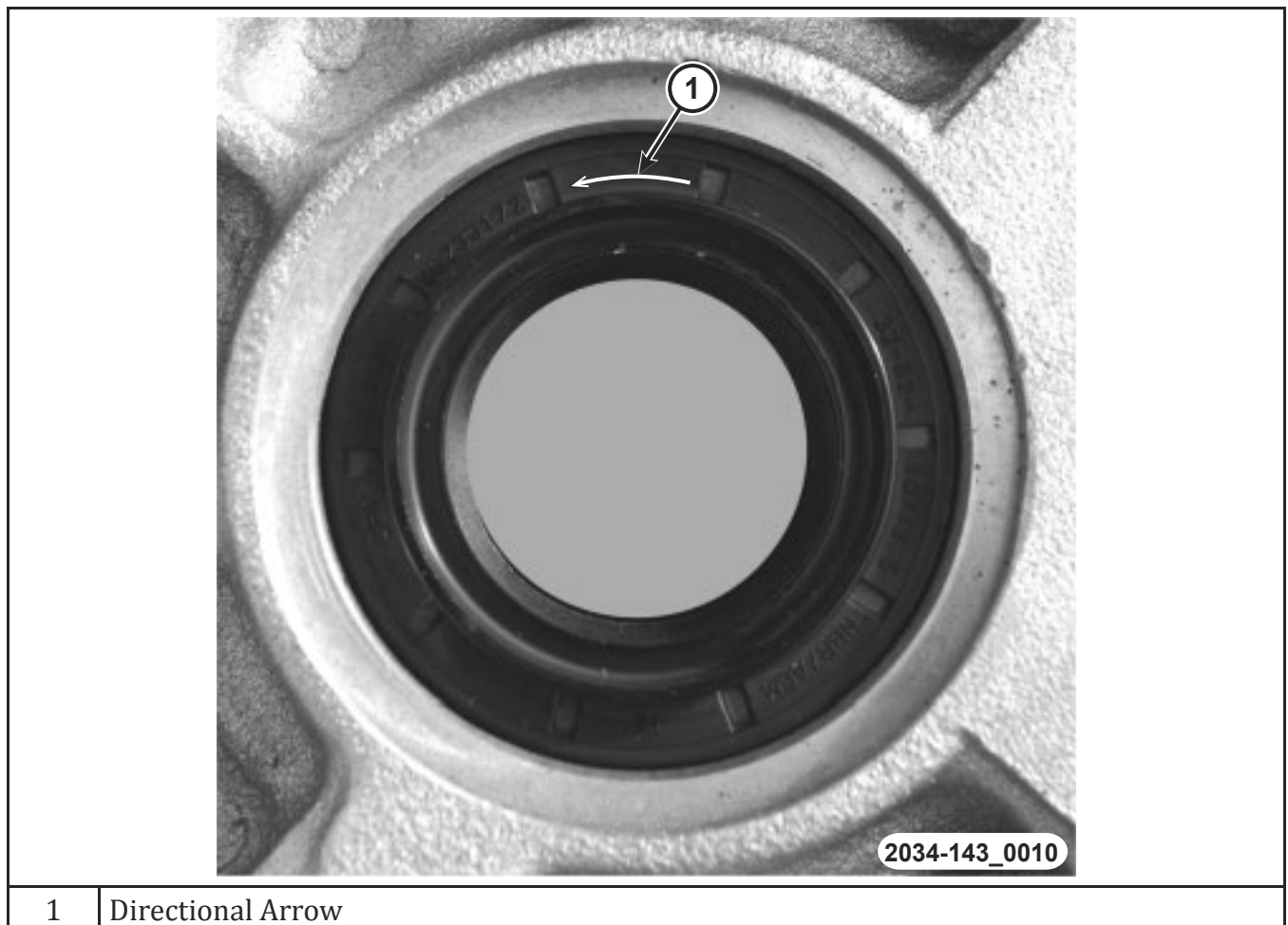

Figure 5 Directional Seals

Some lip seals are directional. Directional seals are uniquely designed to channel fluid back into the transmission with the shaft rotating in one direction. The output shaft seals include grooves that channel the oil into the transaxle housing. The seal for each side is unique to its location on the transaxle. The arrow must point towards the front of the vehicle (the direction the half shafts turn when the vehicle is moving forward).

- The gear case side arrow points counterclockwise
- The bellhousing side arrow points clockwise

NOTE: A direction seal may produce a leak if it is installed in the wrong direction.

Differential Seals

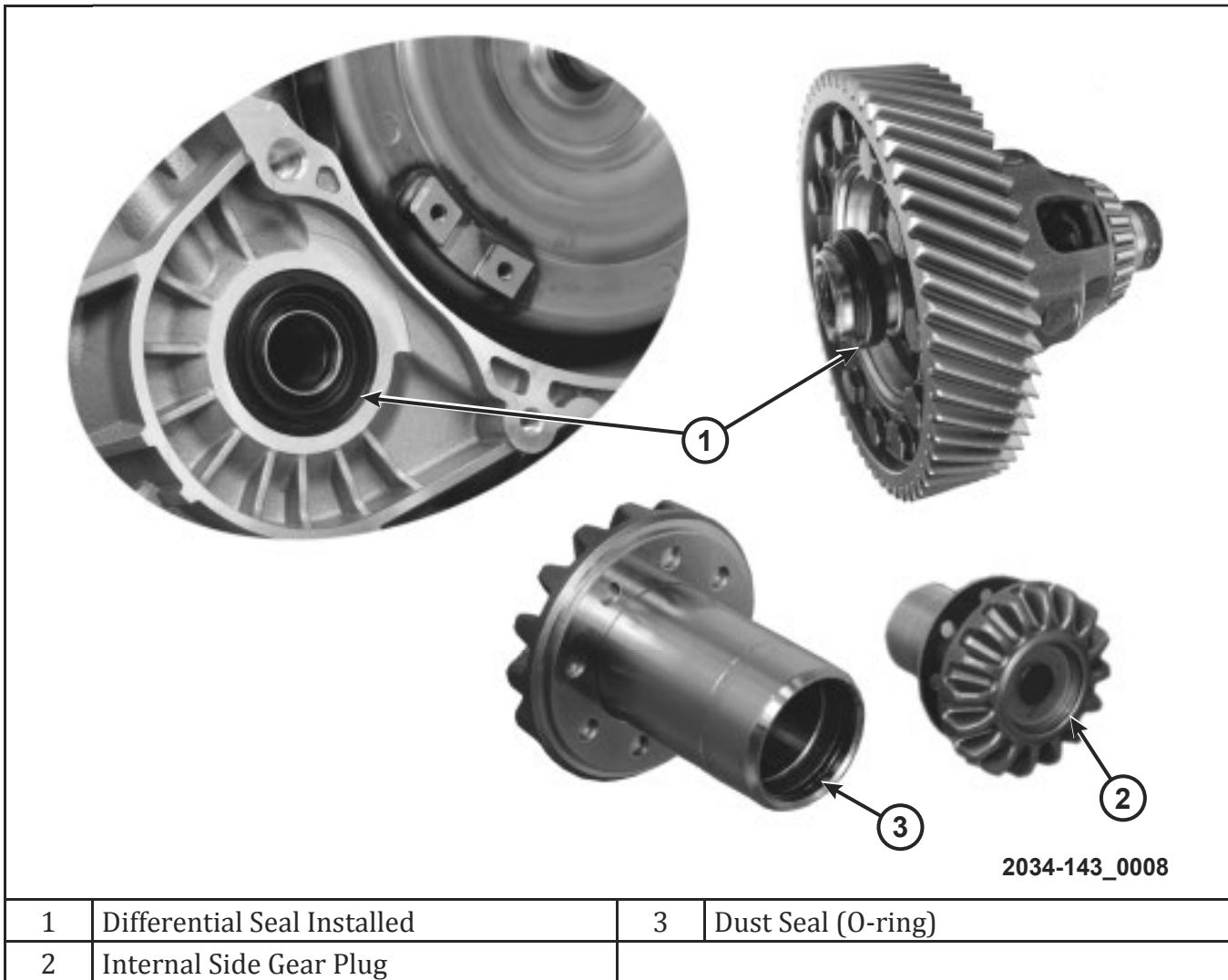
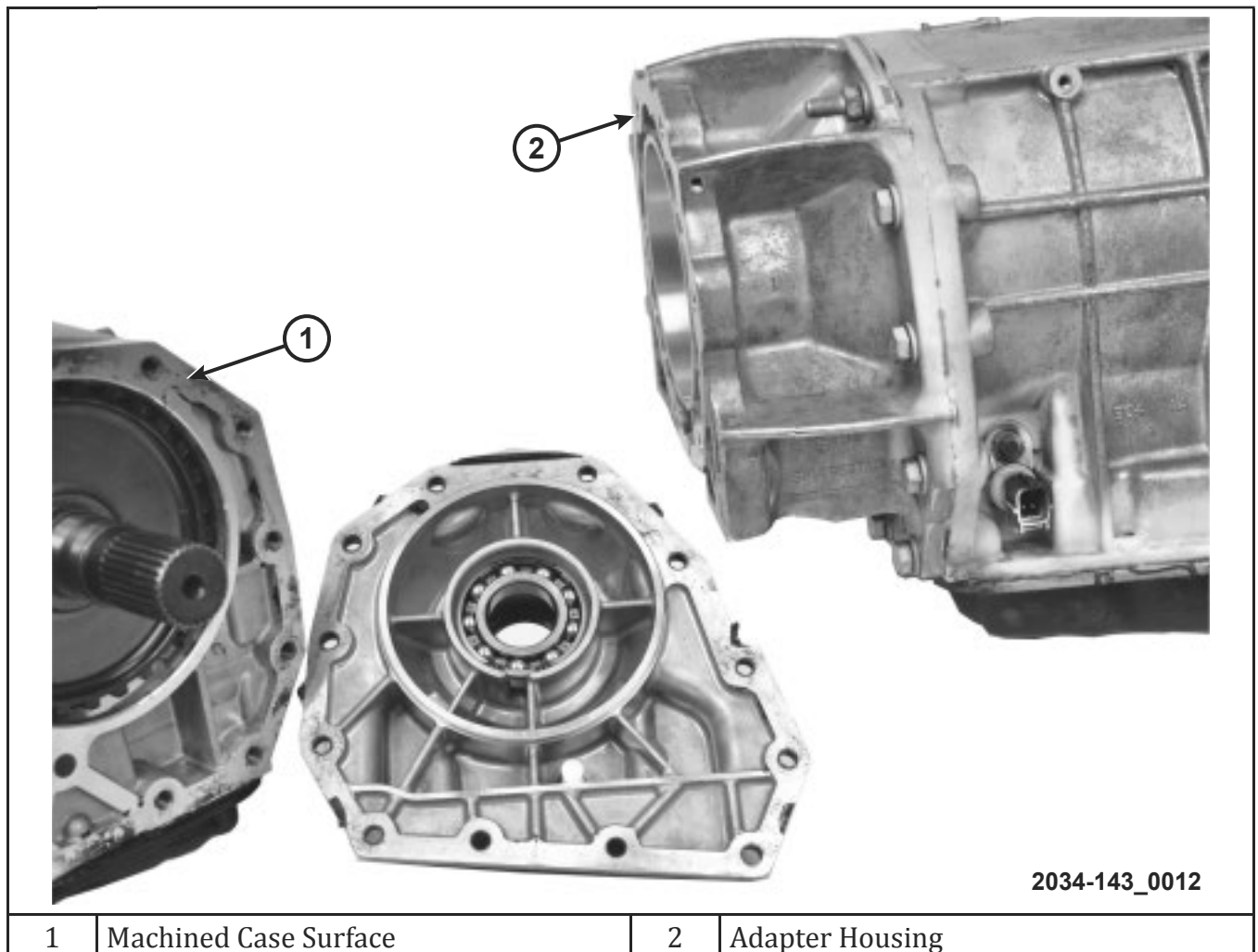

Figure 6 Differential Seals

The differential axle seals in use on some transaxles form the seal on the stub shaft.

The differential assembly houses the side gearset. The stub shaft is incorporated into the side gears and protrudes from the transmission case to become the sealing surface for the axle seals. The side gears are also sealed internally so that no fluid can escape through the center.

Gaskets



1	Machined Case Surface	2	Adapter Housing
---	-----------------------	---	-----------------

Figure 7 Gasket Leaks

Gaskets are used to seal mating components with flat surfaces.

Gasket Locations

Gaskets are used in the following locations on most transmissions:

- Oil pan
- Case halves
- Extension housing
- Pump housing
- Valve body

Many leaks appear to form at the oil pan gasket because the oil drips from above and channels around the lip of the oil pan. Always be sure to track the leak to its highest point.

Reusable Gaskets

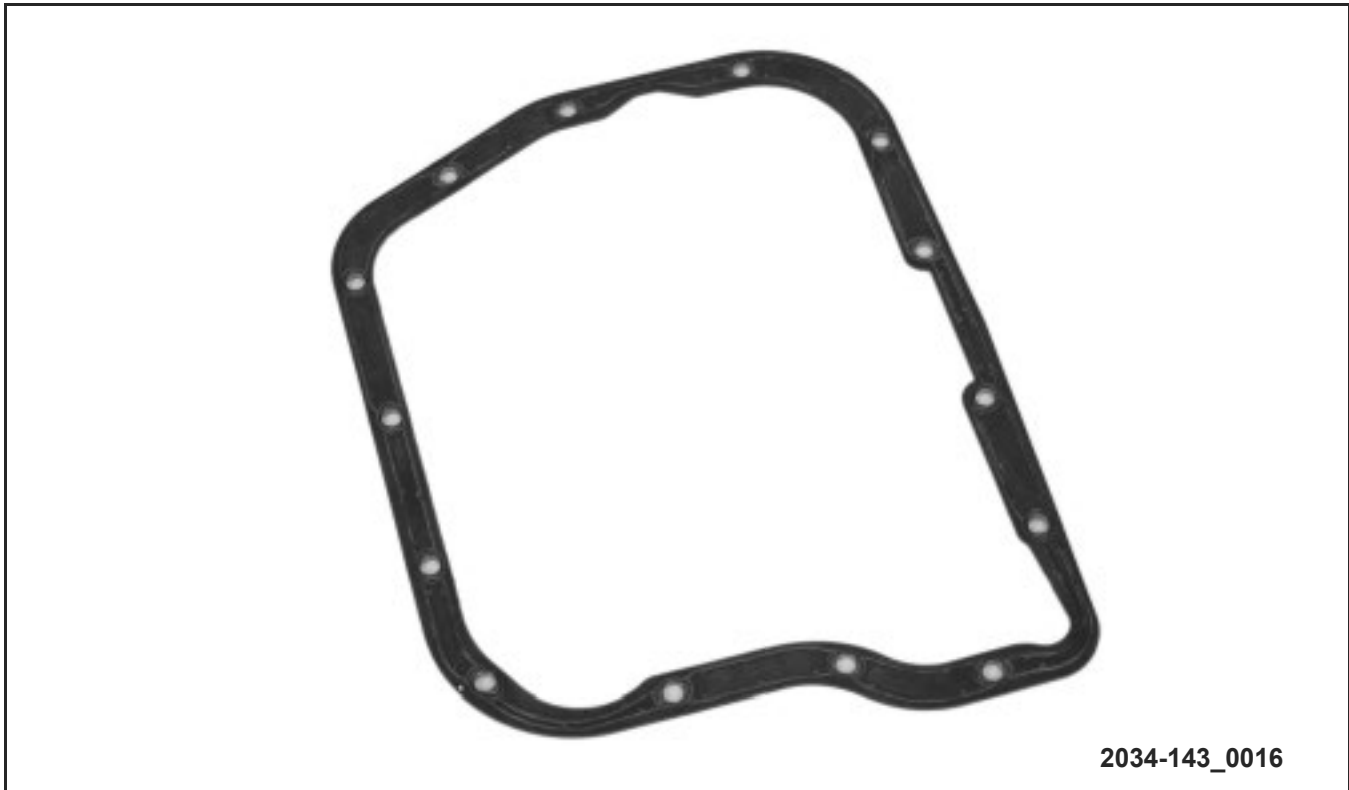

Figure 8 Reusable Transmission Gasket

Reusable gaskets are made of a rubber or plastic composite material. Always inspect the gasket for nicks, cuts, cracks, or deformities.

NOTE: Reusable gaskets should never be cleaned with brake parts cleaner or mineral spirits. Using such cleaning agents may damage the gaskets. Use only clean transmission fluid and a lint-free towel to clean reusable gaskets.

Chemical Sealers



2034-143_0014

1	Anaerobic Sealer	2	ATF RTV Sealer
---	------------------	---	----------------

Figure 9 Chemical Sealers

Anaerobic Sealers

Anaerobic sealers are used in applications where no extra thickness can be tolerated, such as transmission case halves where bearing preload needs to be maintained. This type of sealer cures with the absence of air and is only used where specified in service information.

RTV Sealers

Room temperature vulcanizing (RTV) sealers are used in specific areas of the transmission to create a gasket for proper sealing of two mating components. Be aware that there may be different types of RTV used for different types of engine, transmission, or axle oil. Using the incorrect RTV may result in leaks or foaming of the fluid. Always refer to service information for the correct application.

Fluid Leaks

RTV Sealer Application

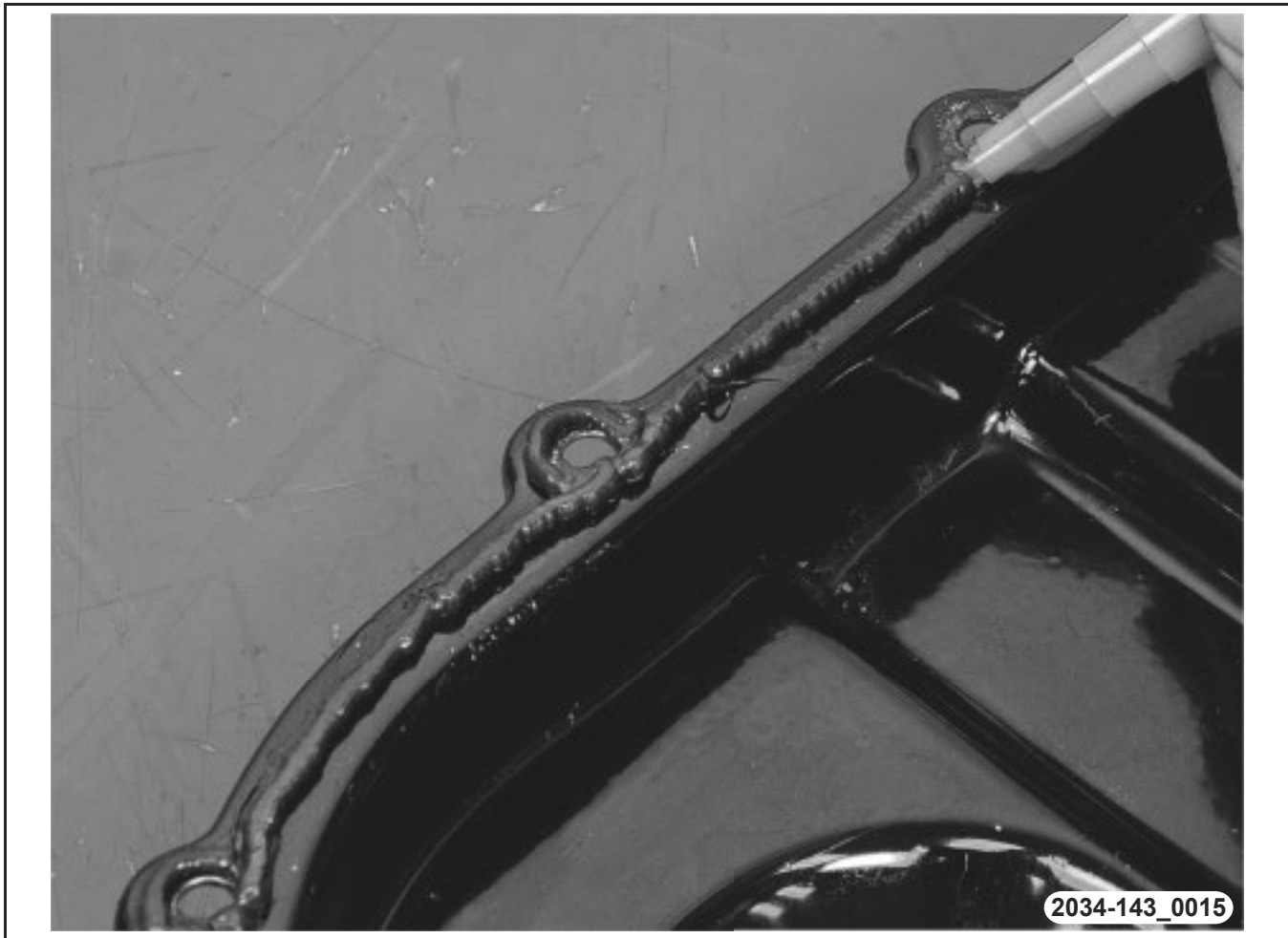

Figure 10 RTV Sealer Application

Sealer Application Methods

Excessive RTV can allow small RTV pieces to circulate through the transmission. To prevent this, use a proper amount of RTV to seal properly, but not so much that the RTV squeezes into the transmission.

CASTING POROSITY

Case Porosity

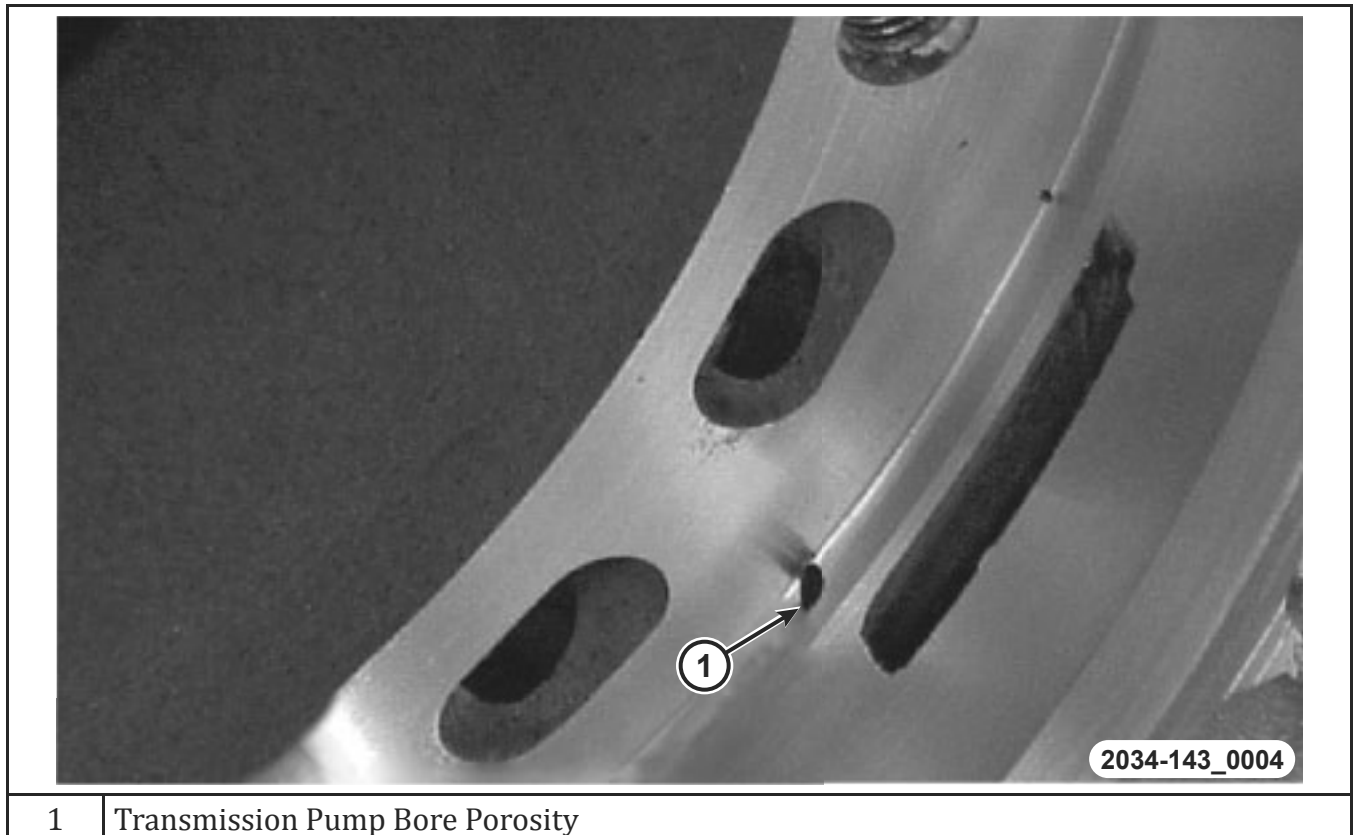

Figure 11 Case Porosity

Transmissions consist of many cast metal pieces connected together. In rare instances, a part may get through production checks with a defect called porosity. This is a void where casting material is missing.

Fluid Leaks

Pump Porosity

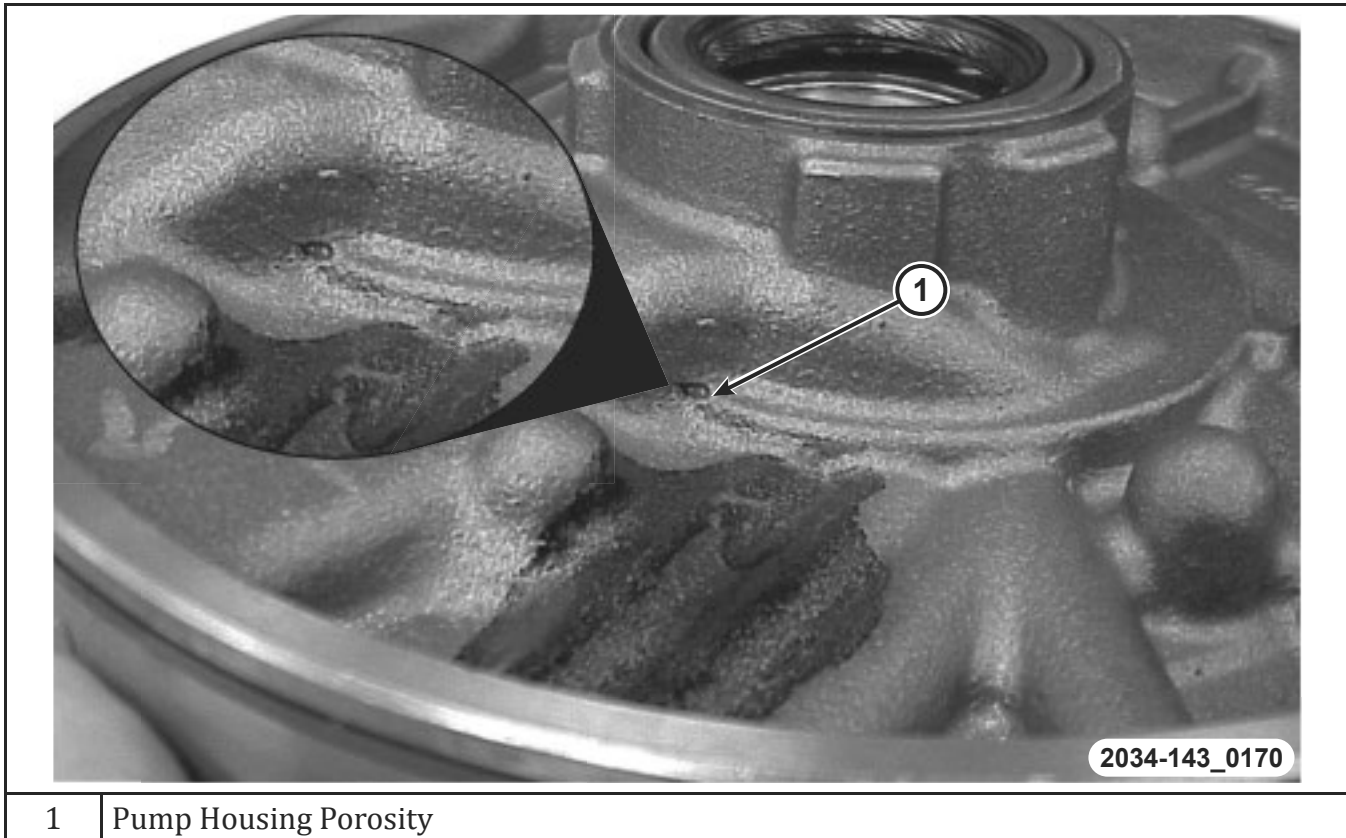

Figure 12 Pump Porosity

Transmission fluid can leak through these porosities, and the leaks can be difficult to find. Some porosity issues can be confirmed by spraying brake parts cleaner on the inside of the case or housing. The brake parts cleaner will quickly wick through the porous material and show on the exterior case surface. A part with this condition usually needs to be replaced.

Fluid Connections

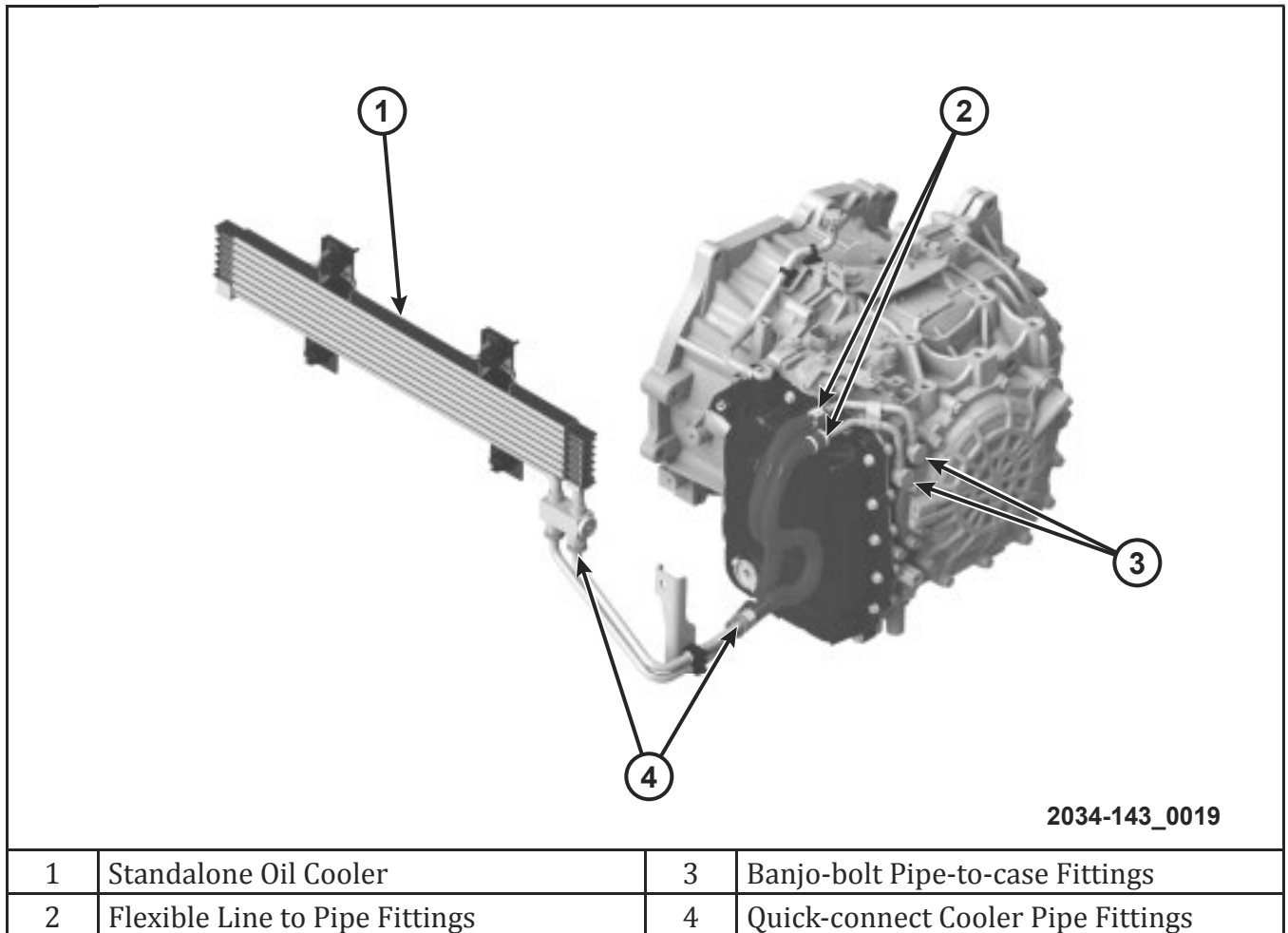

Figure 13 Transmission Cooler Connections

Most automatic transmissions are equipped with an oil cooler and, in some cases, an oil heater to improve transmission function and durability. This normally requires a separate cooler that is located in the vehicle airflow. Metal or flexible tubing is used to carry the fluid to and from the cooler. Fluid leaks can occur at the connections to the oil cooler, the lines, or at the transmission fittings.

Cooler Line Fitting Seal

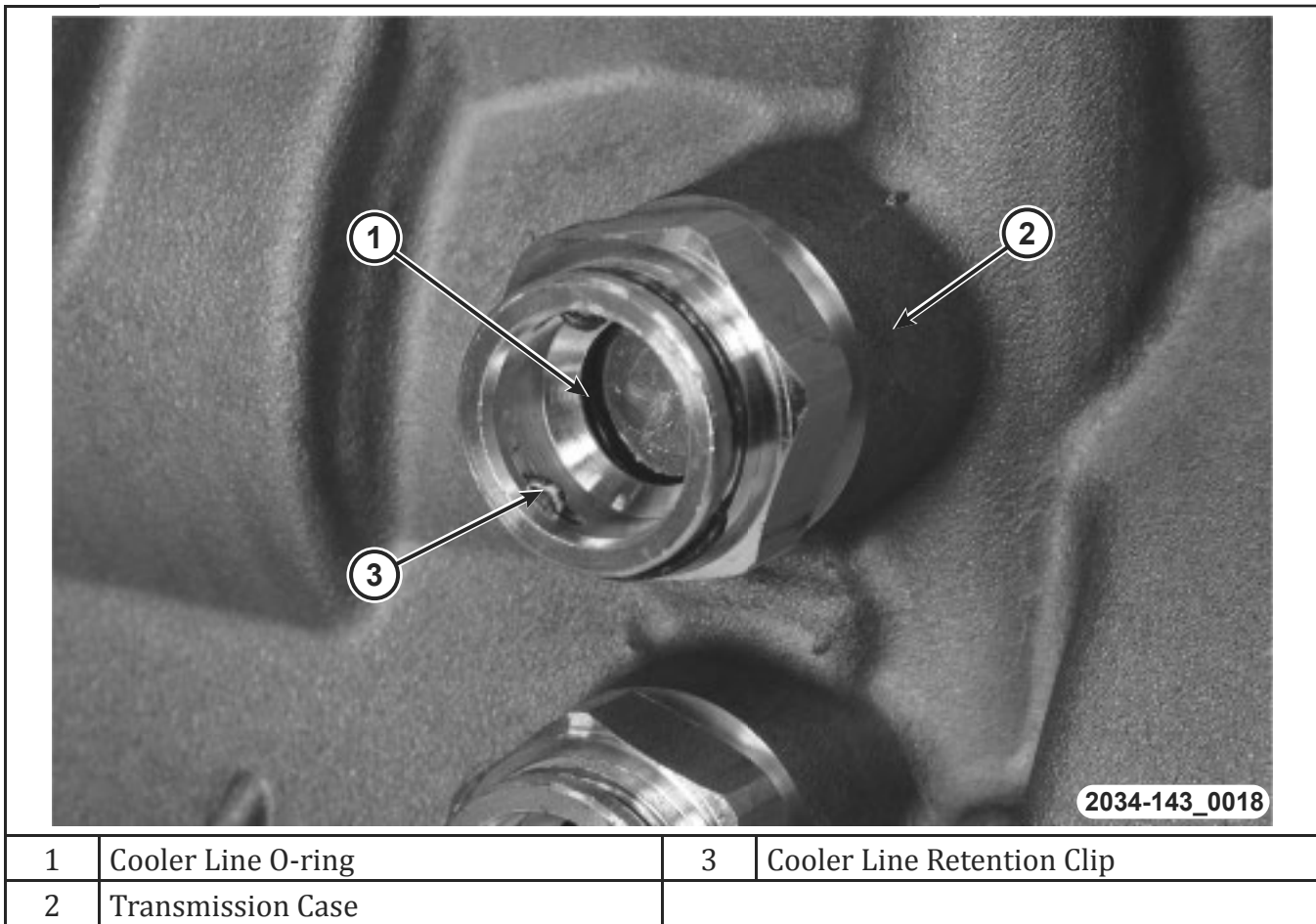

Figure 14 Transmission Cooler Line O-ring Seal

In the application shown, leaks can also occur at the O-ring seals that seal the oil cooler lines to the transmission. Leaks may also occur if the cooler line retention clip is missing, damaged, or improperly seated.

VENT ASSEMBLY LEAKS

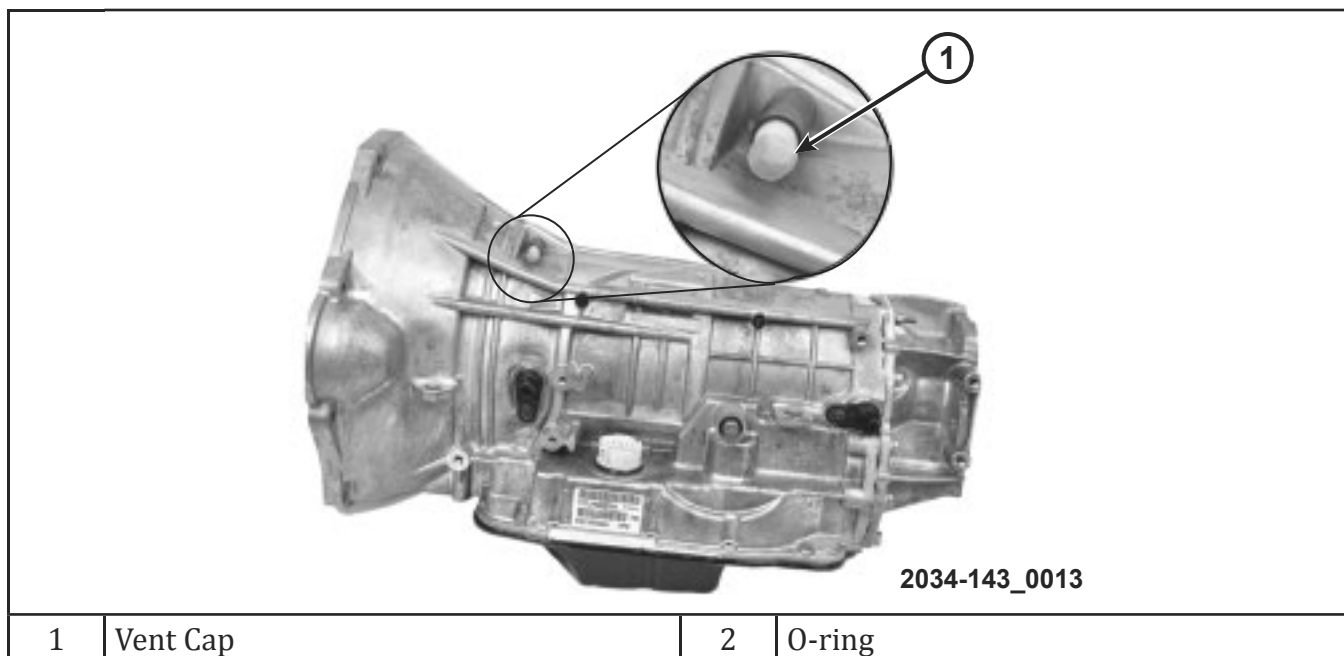

Figure 15 Transmission Vent

Over-Filled

When the fluid level is too high, the fluid comes in contact with the rotating components and becomes aerated. As more air is added to the fluid, it has nowhere to go except out the vent.

Over-Heating

Transmission fluid volume changes greatly with temperature. This is why most transmissions require the fluid level to be checked at operating temperature, when the fluid is expanded, to prevent overfilling. If the temperature of the fluid is hotter than normal, the fluid expands even more. The transmission fluid may then contact the rotating components, as it does when it is overfilled.

Internal Vent Circuit Leak

This type of leak is less common and is caused by fluid pressure flowing through a bad gasket, usually in the pump area, and blowing out the vent. In most cases, the transmission must be removed to repair this fault.

BELLOUSING LEAKS

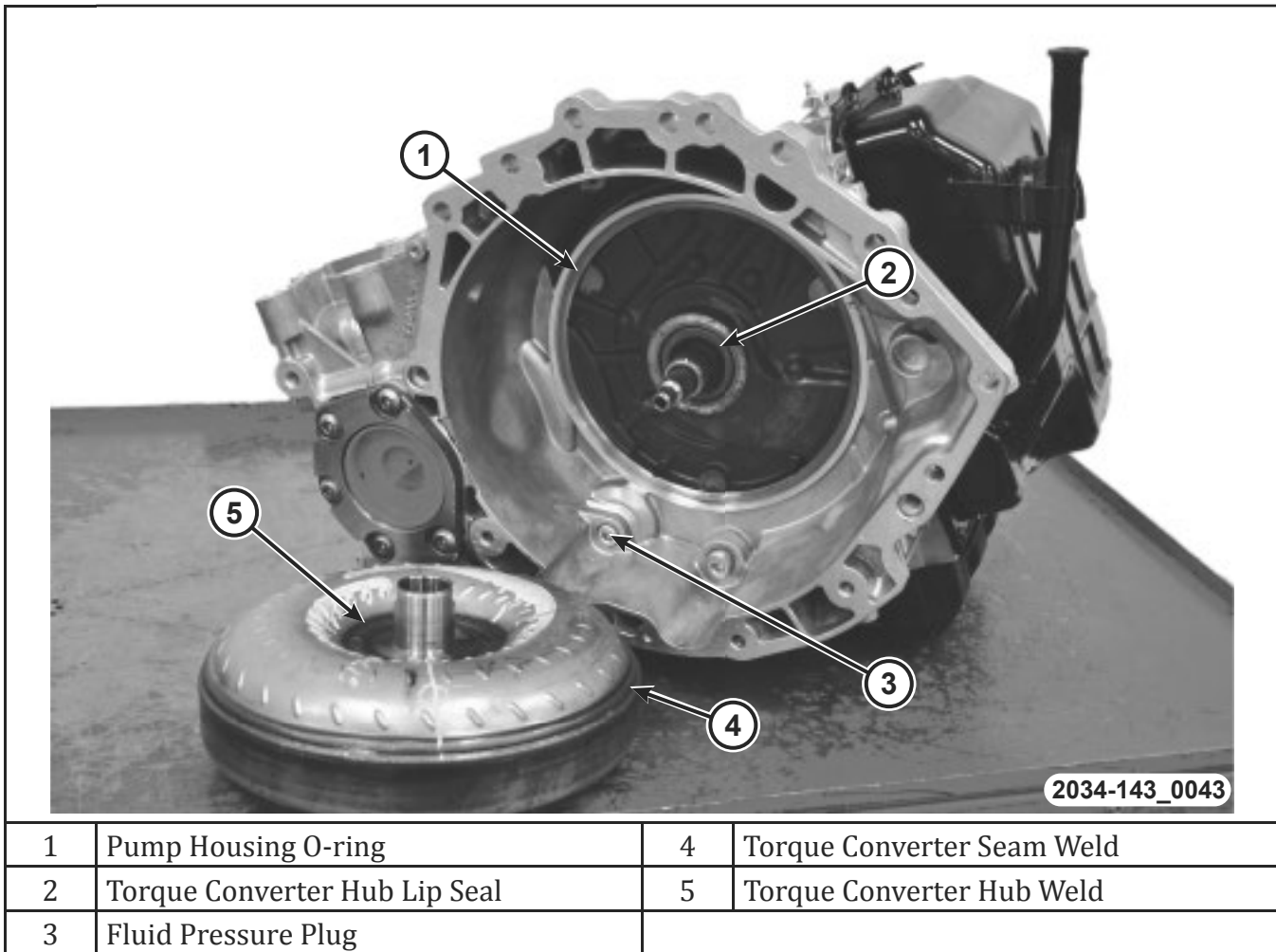

Figure 16 Bellhousing Leak Areas

Fluid leaks in this area can be difficult to diagnose and repair because the transmission must be removed to perform most of the repairs in this area. The rotation of the torque converter tends to sling the oil throughout the bellhousing. It is important to follow the path of the fluid back to its source.

Notes:

Fluid Leaks

Notes:

**DEMONSTRATION 1 LEAK LOCATIONS AND DIAGNOSTIC TOOLS
(62TE BENCH UNIT)**

Instructions: This demonstration covers the key points on leak locations and diagnostic tools. This demonstration page is primarily for notes on the instructor demonstration. It also has a couple of key questions on the topic.

1. What tools are available for leak testing?

2. List the general transmission fluid leak locations below.

3. The pan on a transmission was resealed, but the customer still finds fluid on the garage floor. What are the possible sources of the leak?



ACTIVITY 1 LEAK DIAGNOSIS

TASK ONE: ON-VEHICLE FLUID DYE LEAK INSPECTION

Instructions: For this task, assume the vehicle has come into your shop with a transmission leak concern. The concern has been verified and no related Service Bulletins have been issued.

NOTE: There is no dye used in 8- and 9-speed transmissions.

1. Perform the on-vehicle fluid leak inspection using the black light.
2. After you identify the location of the leak, determine your next step to either perform the repair or determine if further diagnosis is necessary.
3. Use the table below to document any parts that may be necessary to perform the repair and any information the service advisor may need to keep the customer informed.

Leak Source	Comments
(Example) Oil Pan Gasket	The oil pan is leaking Need to pull the pan to inspect the gasket and sealing surfaces to identify the root cause
Leak #1	
Leak #2	
Leak #3	
Leak #4	

Leak Diagnosis

Instructions: Answer the following questions.

4. What causes the fluid to leak from the transmission vent assembly?

5. Can you replace the axle seal or output shaft seal with the transmission in the vehicle?

6. What should you look for before replacing the axle seal or output shaft seal?

7. What should you look for when removing the old axle seal or output shaft seal?



TASK TWO: ON-BENCH TRACING POWDER INSPECTION

Instructions: For this task, assume the vehicle has come into your shop with a transmission fluid leak concern. The concern has been verified. Leak tracing powder has been applied to the transmission, and the vehicle has been road tested. Use the transmission that is on the bench to perform the leak inspection using the tracing powder.

1. Research service information for any related Service Bulletins or Tech Tips. The instructor will provide vehicle information.
 2. Are there any related Service Bulletins or Tech Tips?
-
3. Perform the fluid leak inspection using tracing powder.
 4. Identify each of the leak points you find by marking the area on the transmission image below.

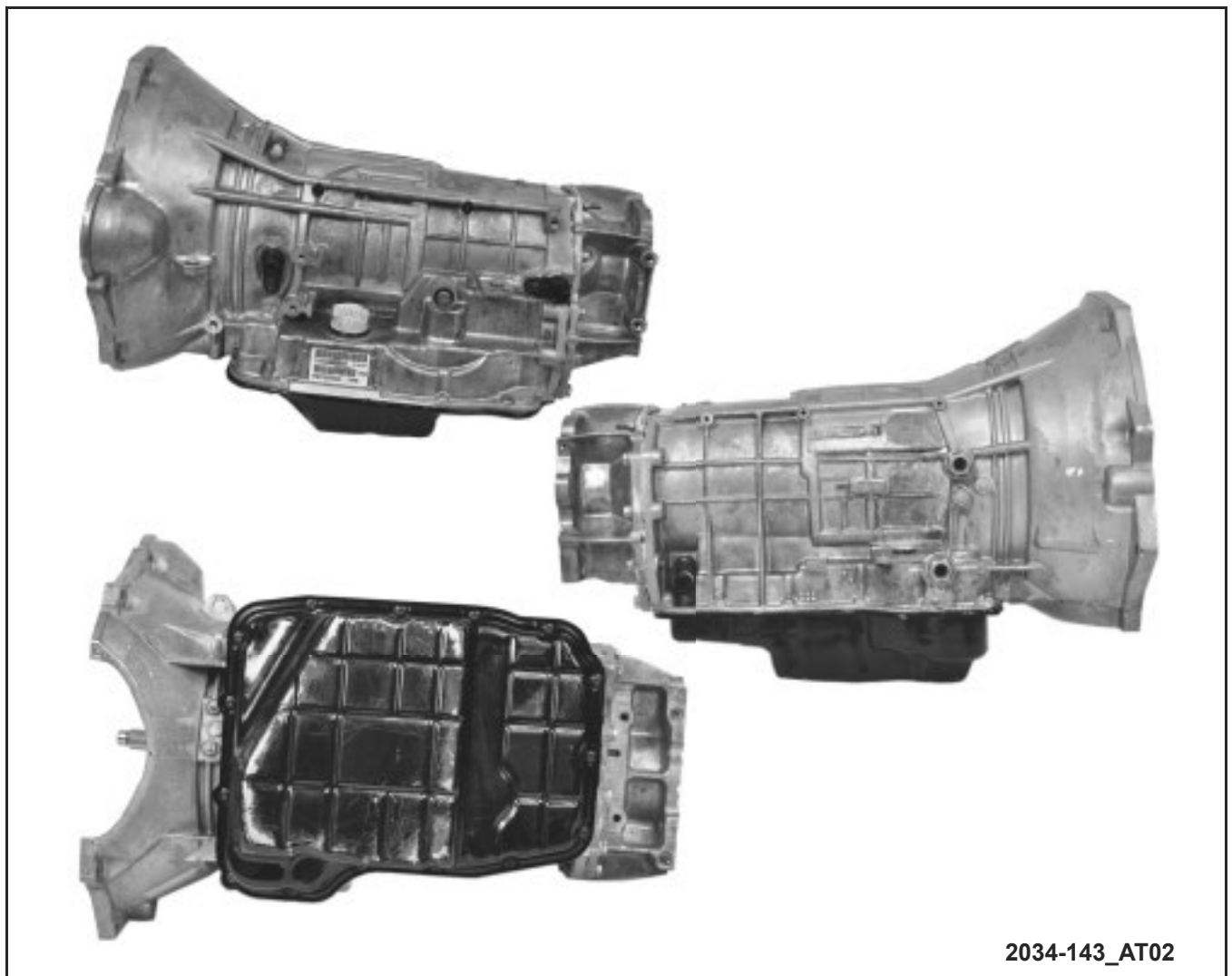

Leak Diagnosis

5. After you identify the location of the leak, determine your next step to either perform the repair or determine if further diagnosis is necessary. Use the table below to document any parts that may be necessary to perform the repair and any information the service advisor may need to keep the customer informed.

Repair Estimate	
Leak Source	Comments
(Example) Oil Pan Gasket	The oil pan is leaking Need to pull the pan to inspect the gasket and sealing surfaces to identify the root cause
Leak #1	
Leak #2	
Leak #3	
Leak #4	
Leak #5	

6. Remove the torque converter to identify the source of the leak from the bellhousing area.
7. What is causing the fluid to leak from the bellhousing area?



LESSON 2 TORQUE CONVERTER AND TEMPERATURE CONTROL

TORQUE CONVERTER COMPONENTS

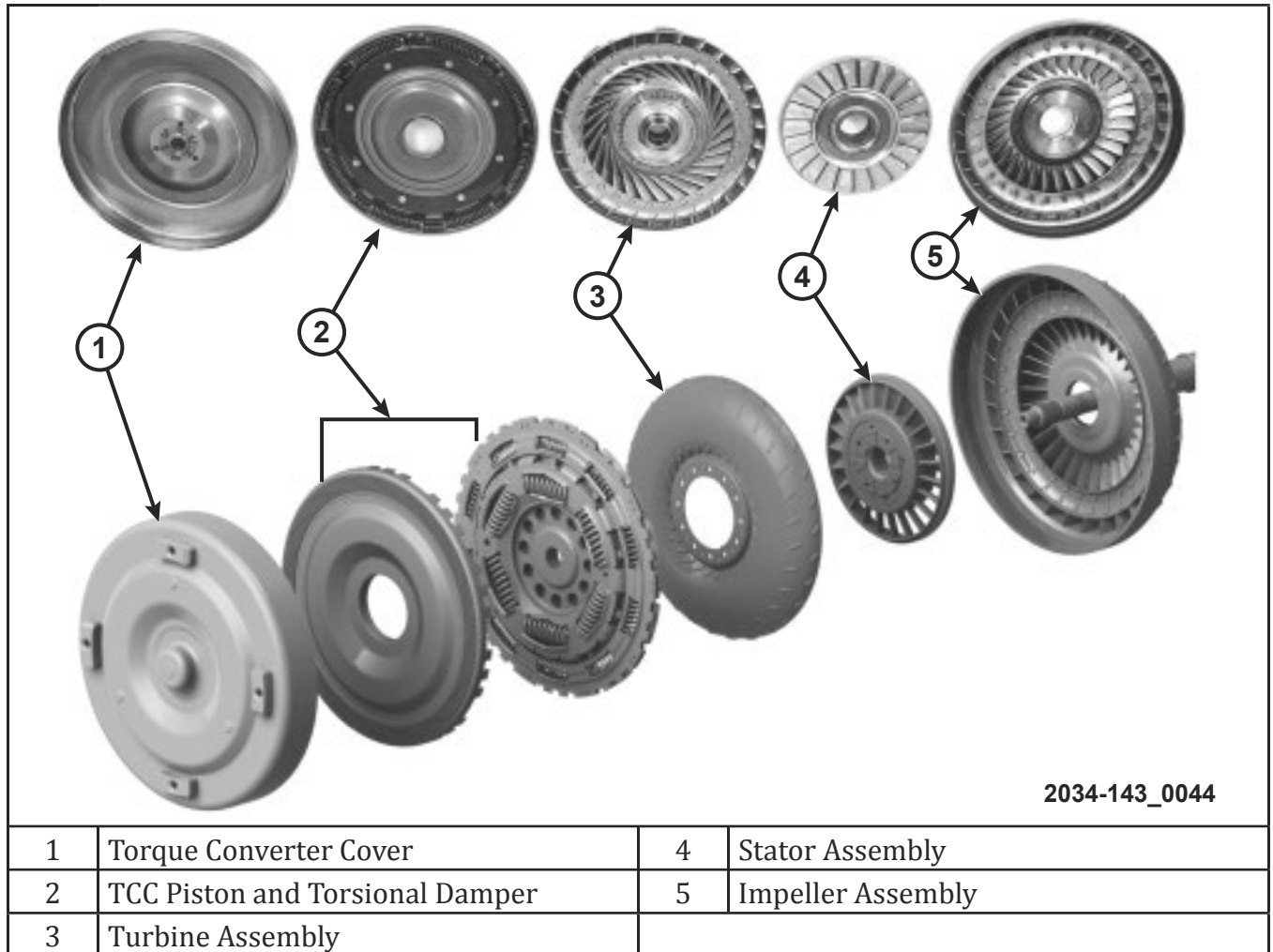

Figure 17 Torque Converter Components

The automatic transmission torque converter is located at the front of the transmission bellhousing. The torque converter transmits torque from the engine to the input or turbine shaft of the transmission.

The torque converter consists of five main members (components):

1. Torque converter (housing)
2. Impeller assembly
3. Turbine assembly
4. Stator assembly
5. Torque converter clutch (TCC) assembly

Impeller Assembly

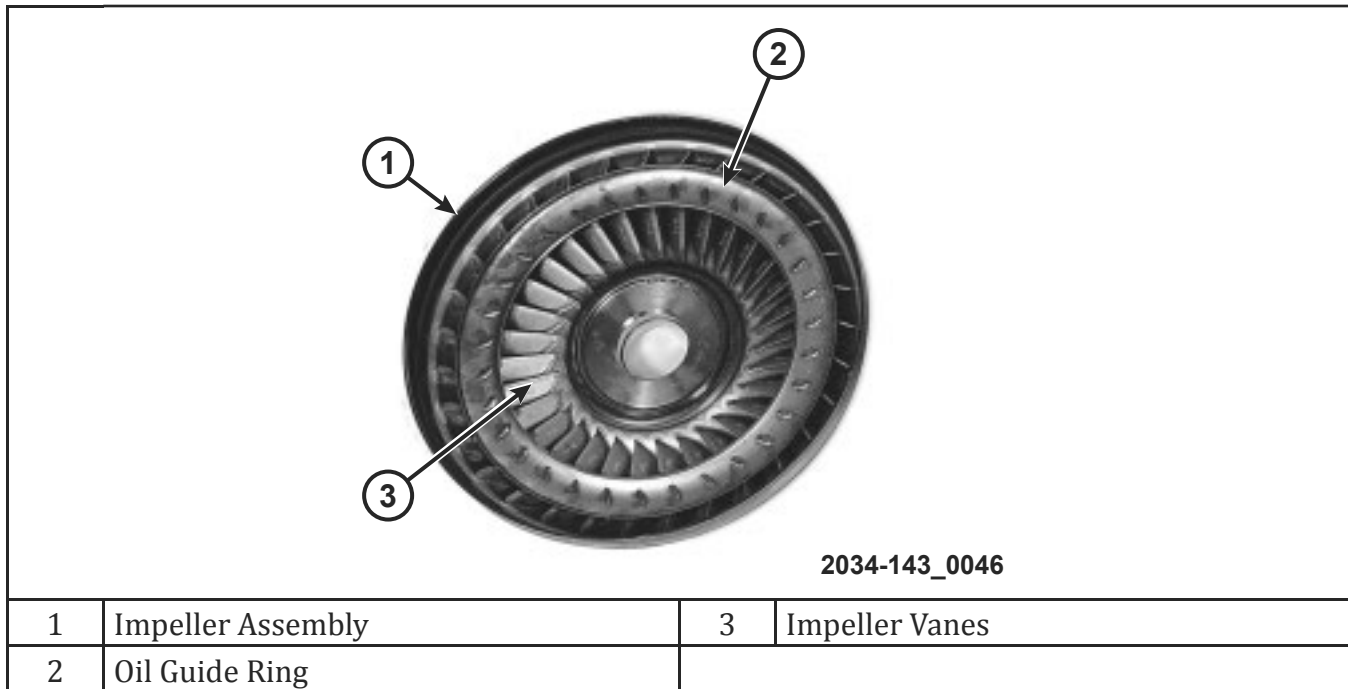

Figure 18 Torque Converter Impeller

The impeller is an integral part of the torque converter housing; the impeller vanes are brazed into the torque converter cover. The impeller consists of curved vanes placed radially along the inside of the housing on the transmission side of the torque converter. As the engine rotates, the torque converter housing and impeller rotate to set the fluid in motion. The impeller always rotates at the same speed as the engine crankshaft.

Guide Ring

The guide ring is a small circular hollow cavity located between the center and outside of the impeller vanes. The purpose of the guide ring is to reduce turbulent fluid flow and promote vortex flow.

Turbine Assembly

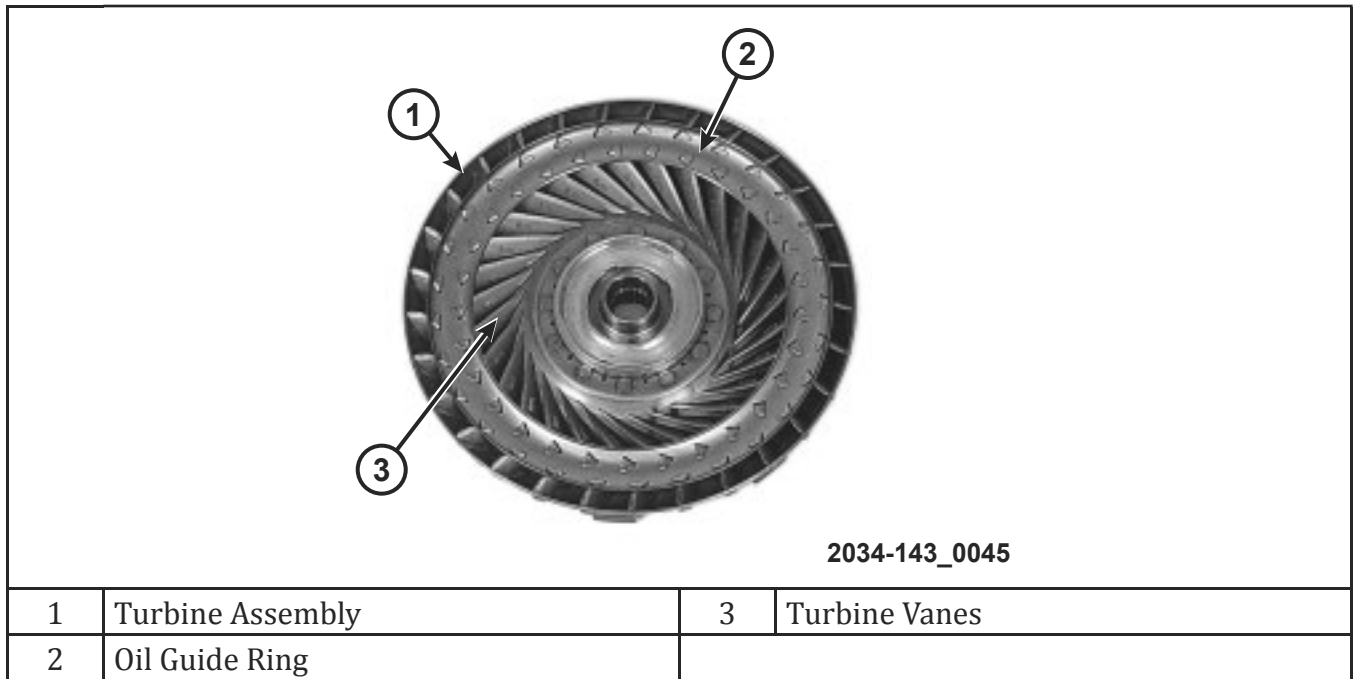

Figure 19 Torque Converter Turbine

The turbine is located opposite of the impeller inside the torque converter housing. The turbine connects to the transmission input shaft through splines. The design of the turbine is similar to the impeller, except that the vanes of the turbine are curved opposite of the impeller vanes.

As the fluid is put into motion by the impeller vanes, it strikes the vanes of the turbine. Some of the energy and rotational force is transferred into the turbine. This causes the turbine and input shaft to rotate in the same direction as the impeller.

Stator Assembly

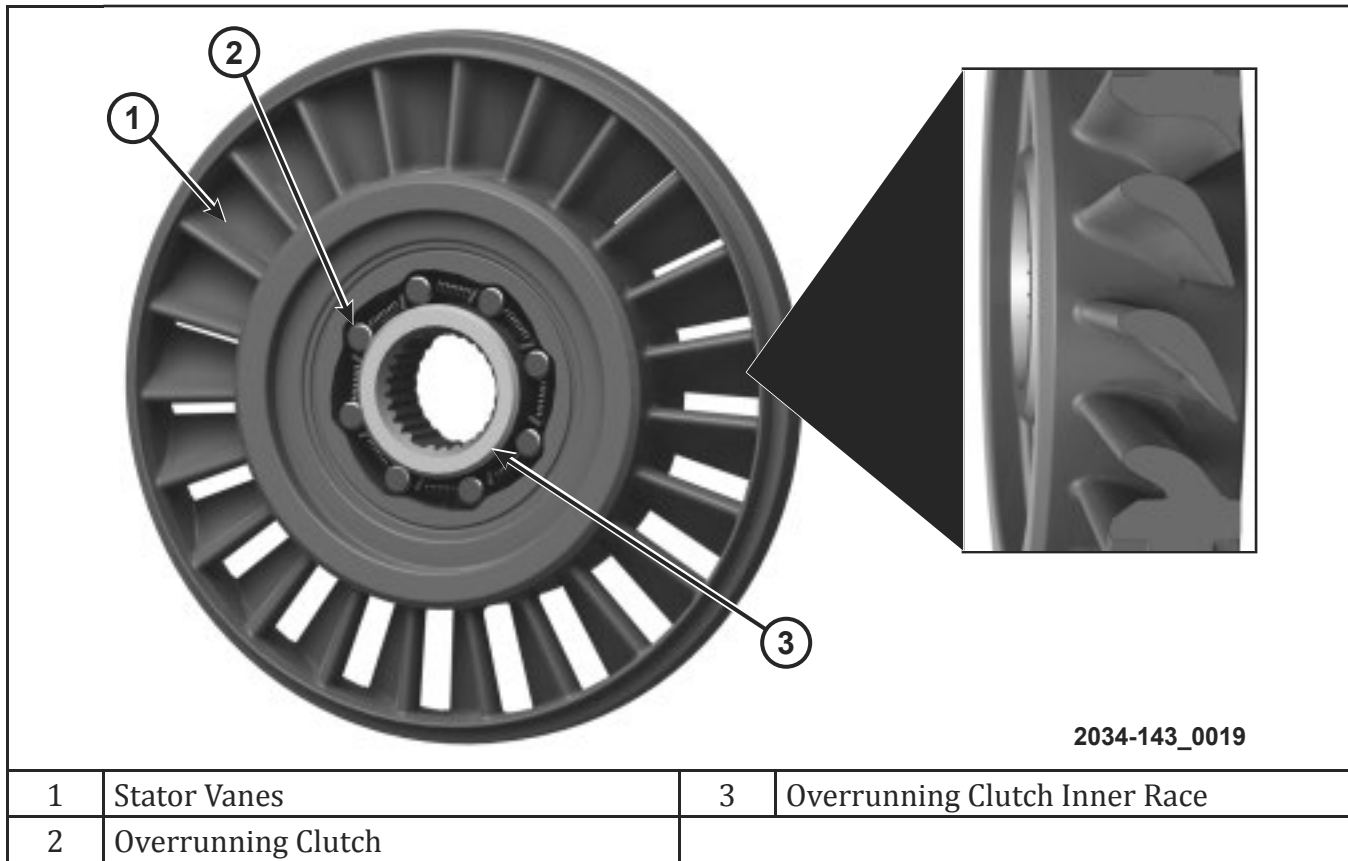

Figure 20 Torque Converter Stator

As the fluid leaves the turbine, it strikes a third set of vanes before returning to and impeding the impeller. The third set of vanes is part of the stator assembly. The stator also contains an overrunning (freewheeling) clutch. The stator assembly is mounted on a stationary shaft that is connected to the case or the oil pump. The stator is located between the impeller and turbine inside the torque converter housing.

The overrunning clutch of the stator allows the stator to rotate only in the same direction as the impeller. Torque multiplication is achieved when the overrunning clutch holds the stator to its shaft.

Without the stator, the impeller and turbine function as a fluid coupling. A fluid coupling has limited efficiency in transferring rotational force from the engine to the transmission. The fluid that strikes the turbine vanes routes back toward the impeller. If the fluid is not redirected before it strikes the impeller, it slows down the impeller.

Torque Converter Clutch (TCC) Assembly

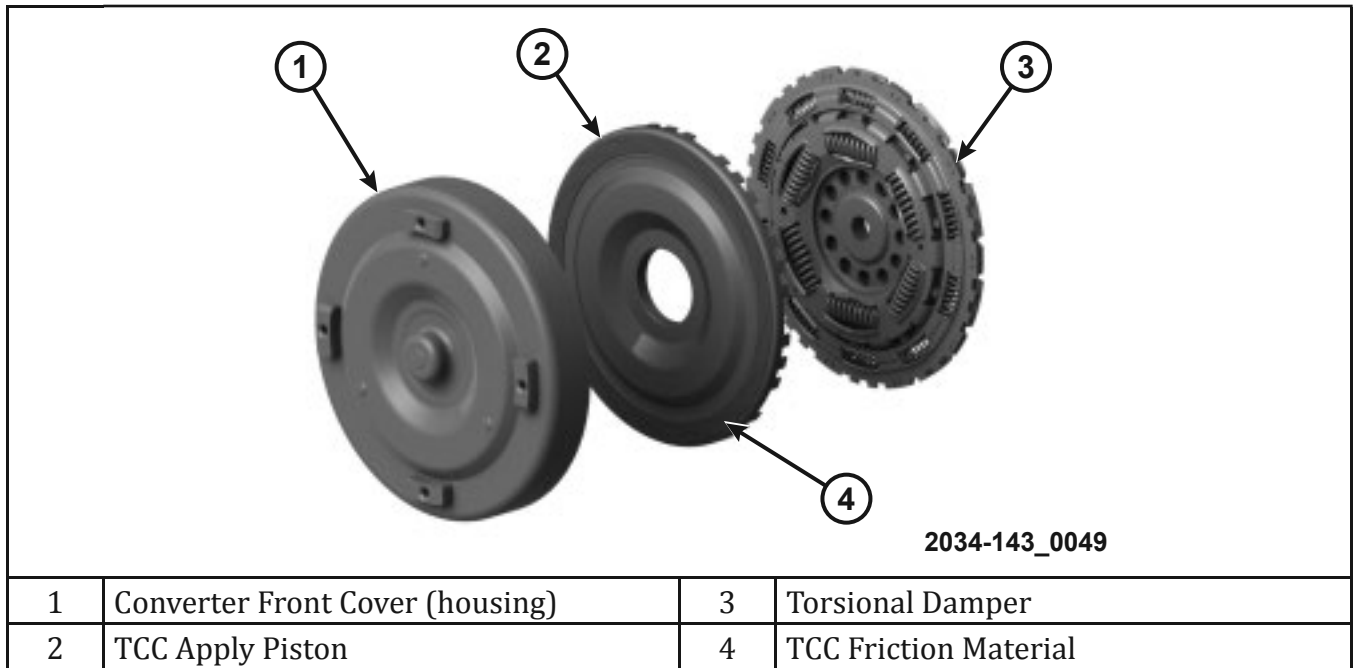

Figure 21 Torque Converter Clutch Components

The TCC—also referred to as an electrically modulated converter clutch (EMCC)—improves the efficiency loss of the torque converter that is due to the slippage of the fluid coupling. Although the fluid coupling provides smooth, shock-free power transfer, it slips and increases the potential for heat generation.

While the vehicle is cruising, the impeller and turbine rotate at nearly the same speed, and the stator is free-wheeling to cancel torque multiplication. If the impeller and turbine are mechanically held together, a zero slippage condition with 100% efficiency can be obtained.

A hydraulic piston is added to the turbine, and friction material is added to the inside of the housing or to the cover side of the apply piston. By applying the turbine piston and friction material, a total converter lock-up can be obtained. The result of this lock-up is a direct 1:1 mechanical link between the engine and the transmission.

The TCC is typically activated while the vehicle is cruising. The application and release of the TCC is automatic and is electronically controlled by the controller.

Torque Converter Fluid Flow

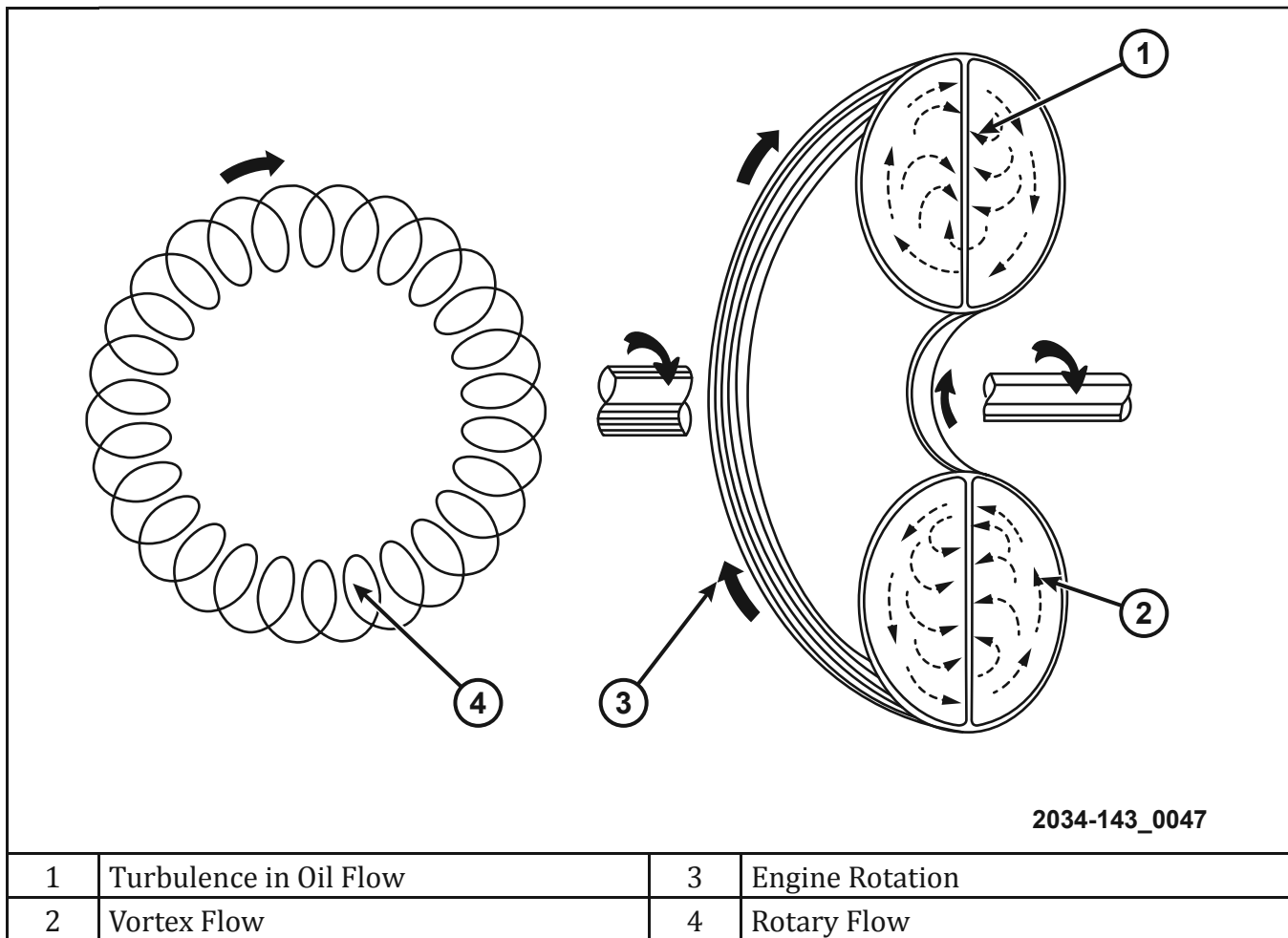

Figure 22 Torque Converter Fluid Flow

The fluid flow in a circular motion through the impeller and turbine is known as the vortex flow.

The rotating impeller moves the fluid inside the converter housing, causing it to rotate around the axis of the converter. This is known as the rotary flow.

Combining these two fluid flows produces a progressive circular (or spiraling) motion. This is known as the spiral flow.

Turbulence is the random motion or agitation of the fluid during the coupling process. When the vehicle is stopped and in Drive or Reverse, impeller speed is at engine speed and the turbine speed is zero because the vehicle is stopped. Fluid flows at high velocity from the revolving impeller through the stationary turbine and stator. The fluid shearing that occurs in this state is the primary source of heat generation in the transmission.

When the turbine starts to rotate and increases in speed, the centrifugal force on the fluid in the turbine opposes the high-velocity flow from the impeller. This reduces vortex flow and torque multiplication.

TORQUE CONVERTER MECHANICAL OPERATION

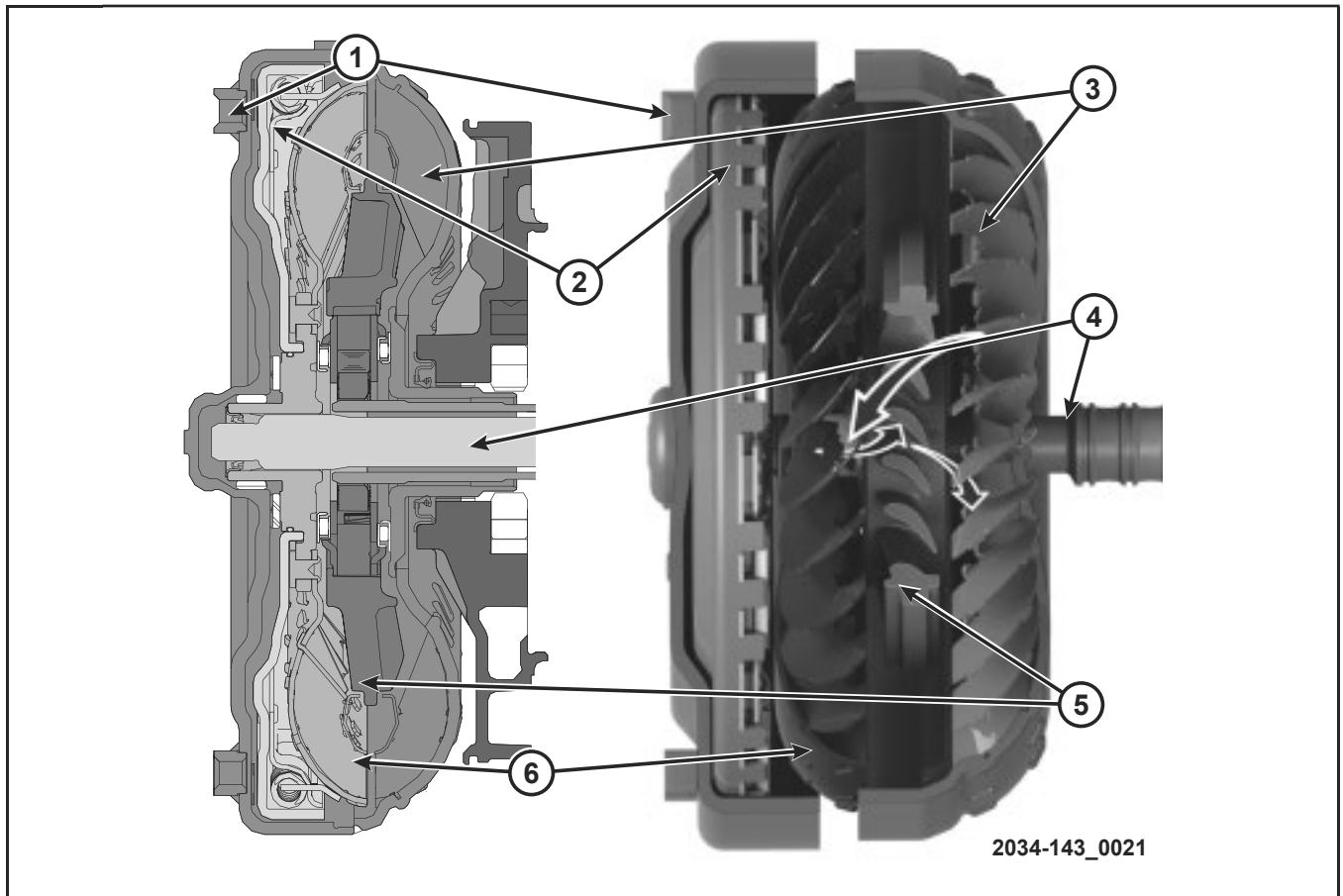

1	Torque Converter Bolt	4	Input (turbine) Shaft
2	Torque Converter Clutch Piston	5	Stator Assembly
3	Impeller Assembly	6	Turbine Assembly

Figure 23 Torque Converter Operation

When the vehicle is stationary, the turbine is stationary and not rotating. The fluid leaving the turbine vanes strikes the face of the stator vanes and pushes them opposite of engine rotation. When this happens, the overrunning clutch of the stator holds the stator from rotating. With the stator held stationary, the fluid strikes the stator vanes and is redirected into a helping direction before it re-enters the impeller.

This circulation of fluid from impeller-to-turbine, turbine-to-stator, and stator-to-impeller can produce a maximum torque multiplication of about 2.2:1.

Stator Operation

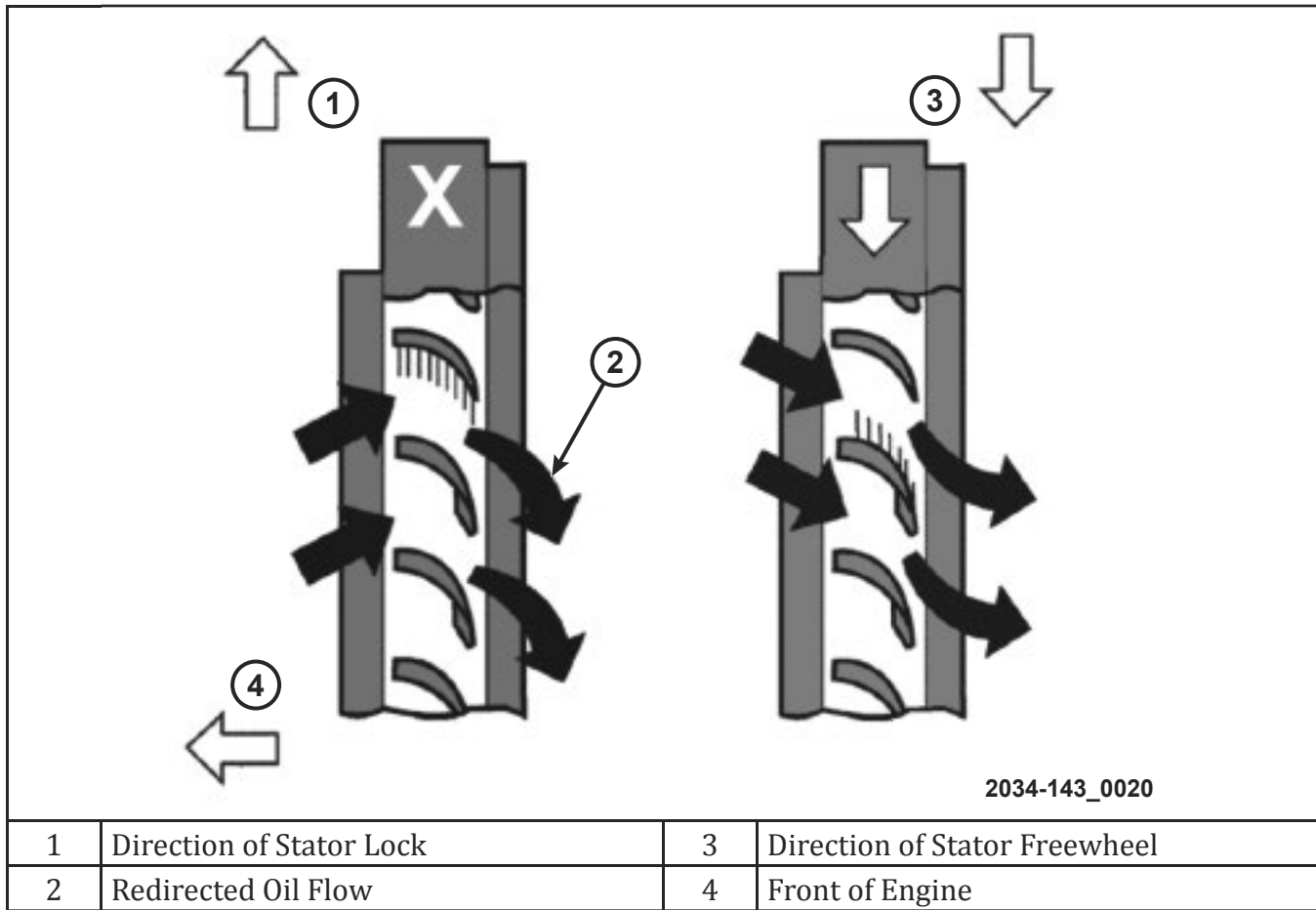

Figure 24 Stator Lock and Freewheel Modes

As the turbine speed begins to match the impeller speed, the fluid that was hitting the stator and causing it to lock-up changes direction. In this mode of operation, the stator begins to freewheel and the torque converter acts as a fluid coupling.

TORQUE CONVERTER HYDRAULIC OPERATION

Torque Converter Pressure Regulation

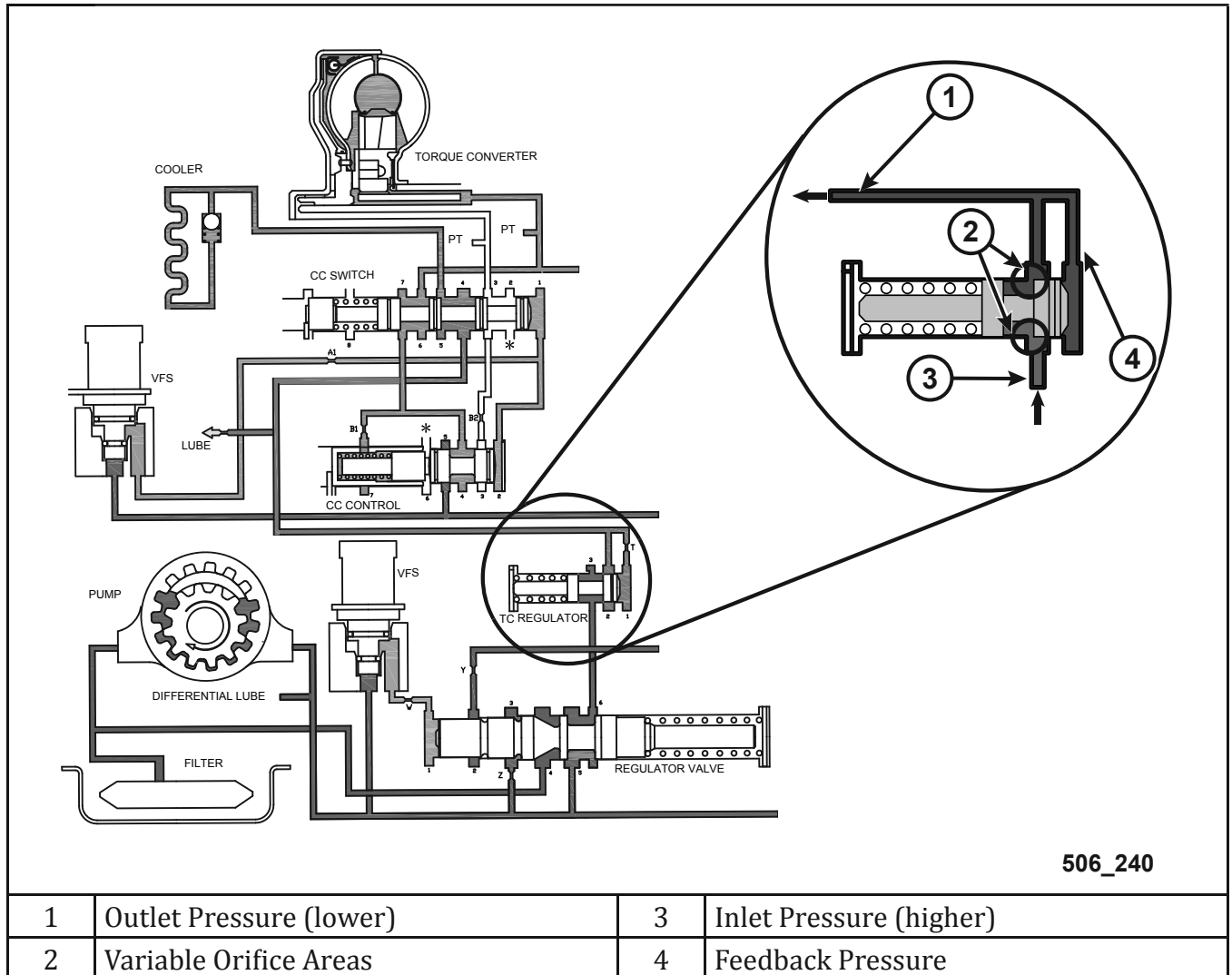

Figure 25 Torque Converter Pressure Regulator Valve

The fluid provided to the torque converter starts at a pressure regulation valve. This valve reduces the transmission line pressure to the appropriate pressure for the torque converter. The torque converter pressure regulator valve works similarly to other pressure regulation/reducing valves.

Hydraulic pressure over spring force determines the reducing valve's operating position. The pressure at the inlet port of a regulating valve is higher than the pressure at the outlet port. The position of the valve in its bore creates a variable orifice at the edge of the valve lands to control the pressure in the outlet circuit.

In order for a pressure regulating valve to operate, the outlet circuit must have a vent/exhaust to allow fluid flow. Without this vent, the outlet pressure quickly matches the inlet pressure and the valve no longer regulates pressure. In the torque converter regulator circuit, the fluid flows to the converter and then either exhausts through the cooler to the sump or the lubrication circuits.

Torque Converter and Temperature Control

Converter Control Switch Valve

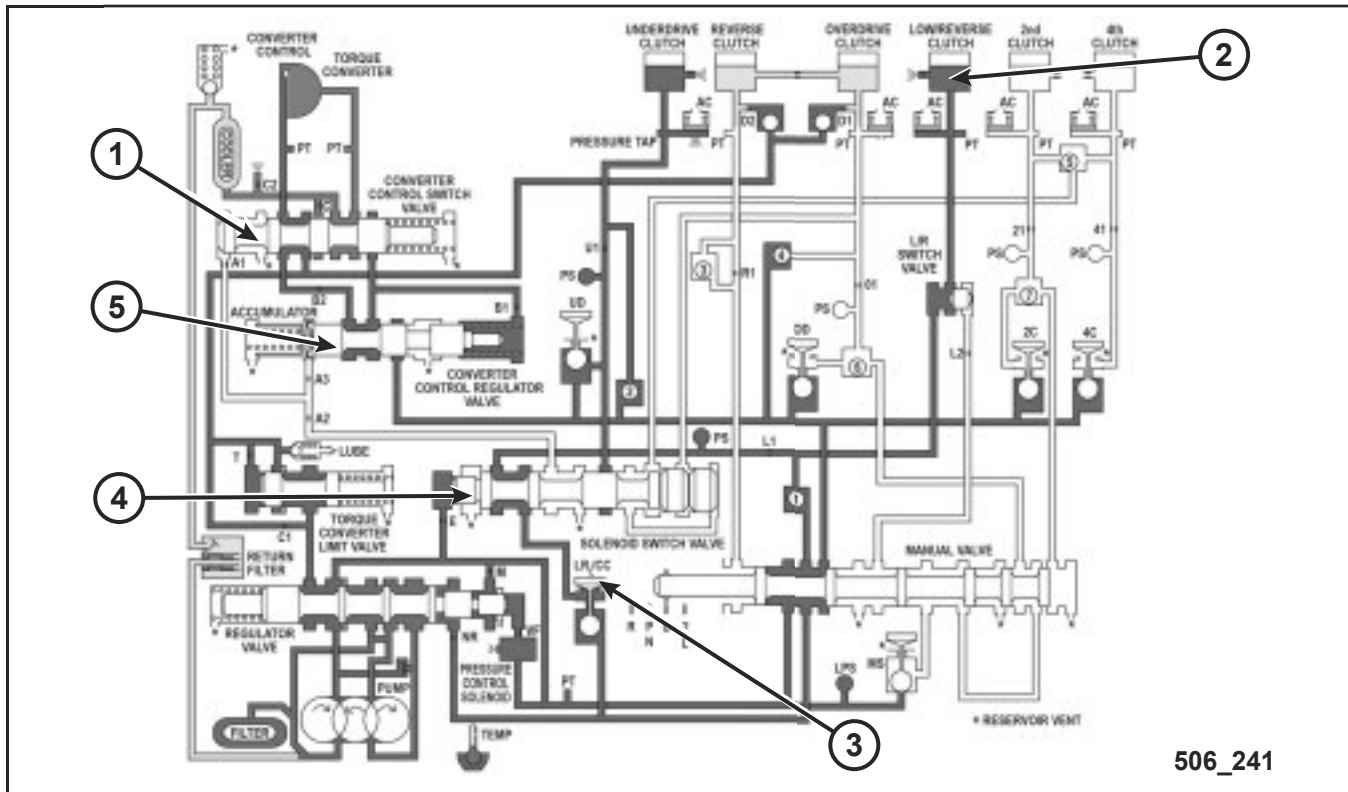

1	Converter Control Switch Valve	4	Solenoid Switch Valve
2	Low Reverse Clutch	5	Converter Clutch Regulator Valve
3	LR/CC Solenoid		

Figure 26 Converter Control Switch Valve with TCC Released (RFE shown)

The converter control switch valve is a type of switching valve that controls fluid flow through the torque converter. The position of the valve is controlled by fluid pressure from the solenoid switch valve on one end of the valve and the spring pressure on the other end.

In the at-rest position, the spring pushes the converter control switch valve to the left, directing fluid pressure to the converter control (clutch) piston, releasing the TCC. Fluid flow out of the converter is directed to the cooler through the converter control switch valve.

Converter Control Switch Valve (continued)

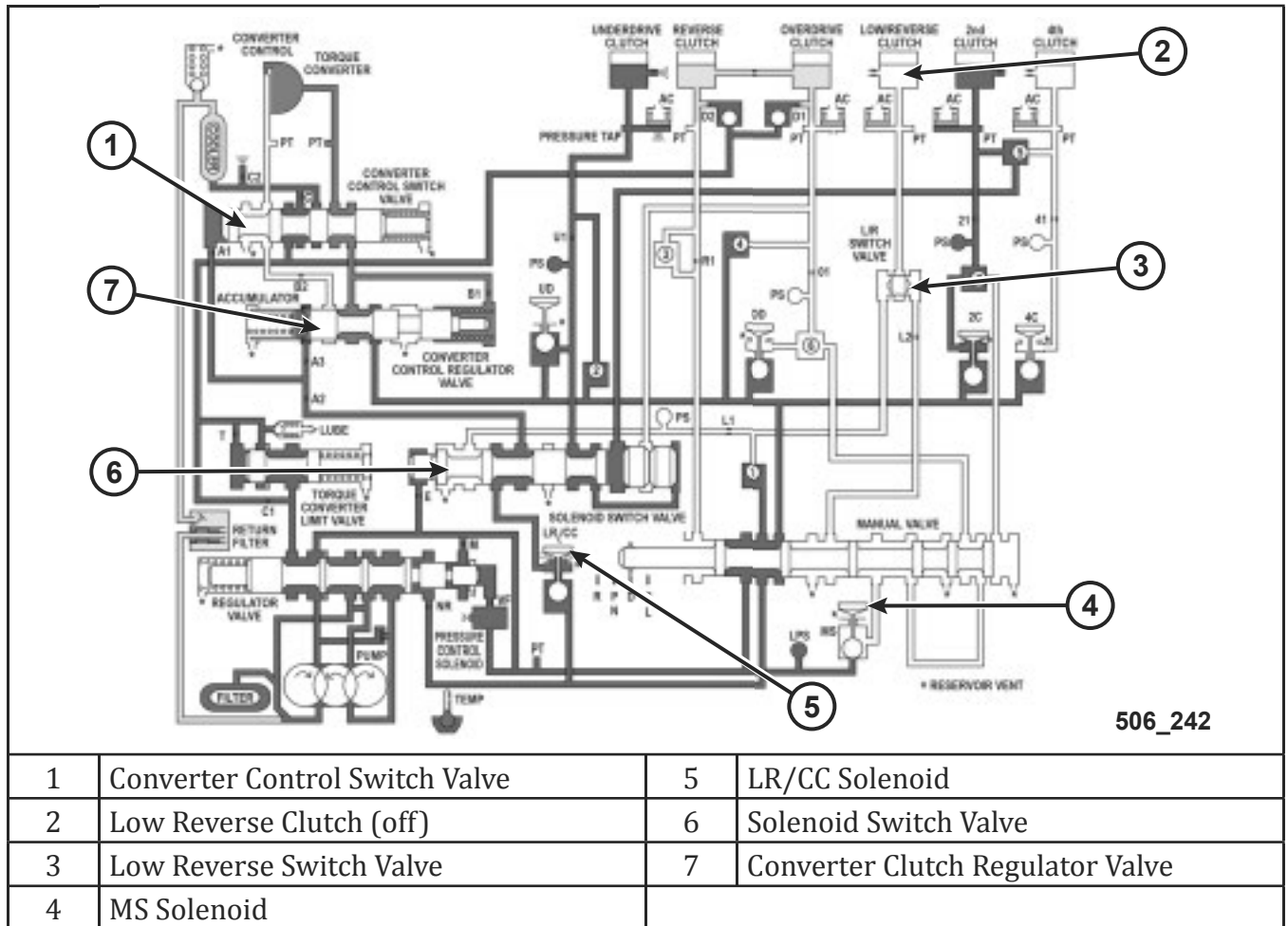

Figure 27 Converter Control Switch Valve with TCC Applied (RFE shown)

When fluid pressure from the solenoid switch valve is applied to the converter control switch valve, the spring is overpowered and the valve shuttles to the right. This turns off fluid flow to the front of the torque converter clutch, allowing it to apply TCC. The pressure in the converter is pushing on the TCC apply piston and does not flow out. Fluid from the transmission is routed by the converter control valve to bypass the converter and flow to the cooler.

TORQUE CONVERTER CLUTCH (TCC) MECHANICAL OPERATION

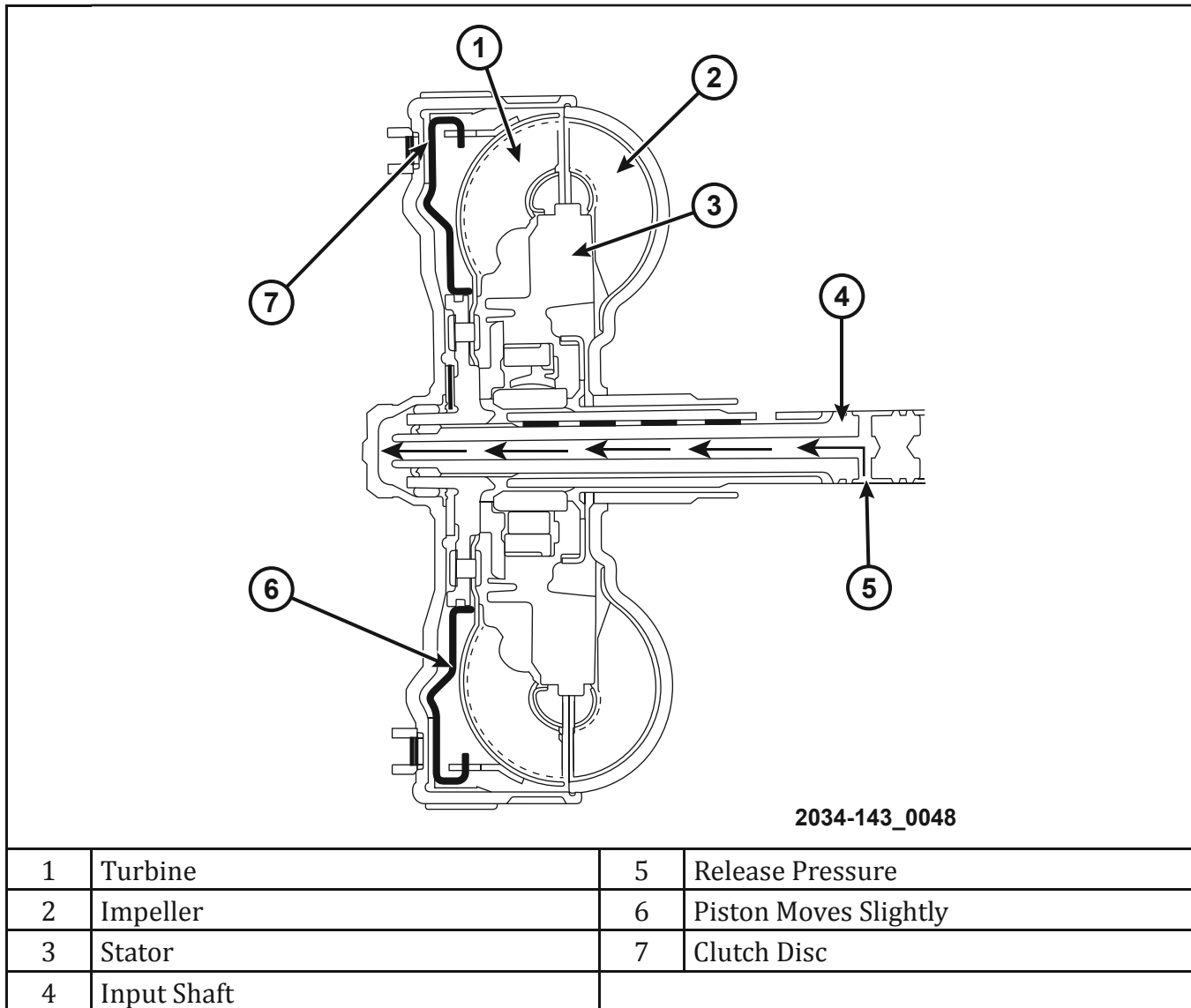

Figure 28 Torque Converter Clutch Operation

There are two basic designs of the torque converter clutch. They are identified by the hydraulic control. The two-channel system is the most common and uses two circuits to control both the flow through the converter and the TCC apply and release. The three-channel system uses three circuits, two for fluid flow and one for TCC control. Torque converter clutch operation is controlled by the TCM through the TCC solenoid and valve body.

TORQUE CONVERTER CLUTCH (TCC) HYDRAULIC OPERATION

Two-Channel TCC Control Circuit

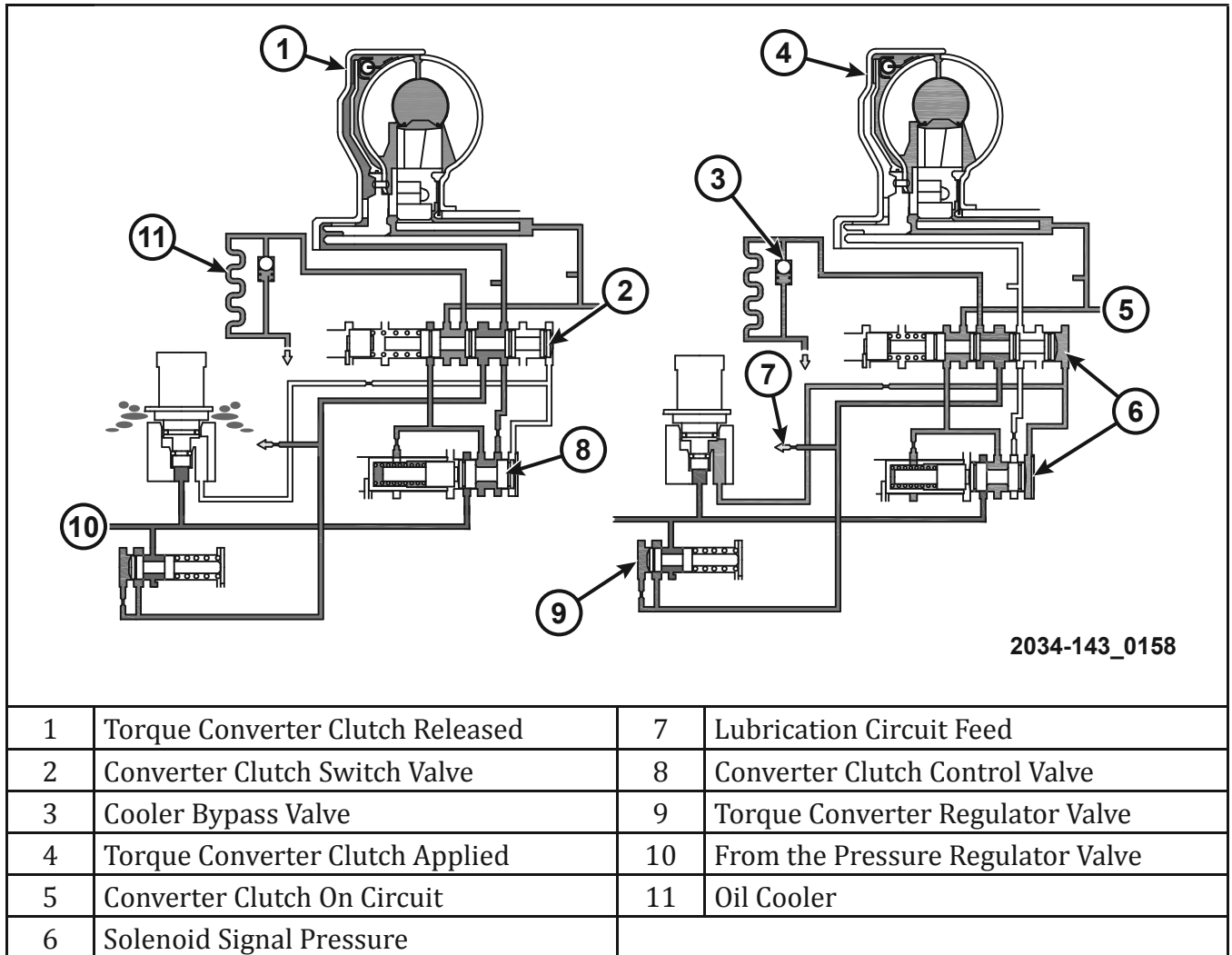

Figure 29 Torque Converter Clutch Control Circuits (62TE shown)

When the TCC is disengaged, fluid under pressure moves through the center of the input shaft to the cover side of the piston. This fluid pushes the piston away from the cover and allows fluid flow around the outer edge of the piston. The fluid exits the torque converter between the input shaft and the stator reaction shaft.

To engage the TCC, fluid pressure on the front side of the piston is shut off and the circuit is vented. Fluid under pressure is then directed to the back side of the piston and pushes the piston forward to connect the turbine to the converter front cover. Because the piston has no outer seal, the friction disc provides the seal between the piston and the converter front cover.

When the clutch is engaged, fuel economy improves, and the transmission temperature is reduced.

Three-Channel TCC Control Circuit

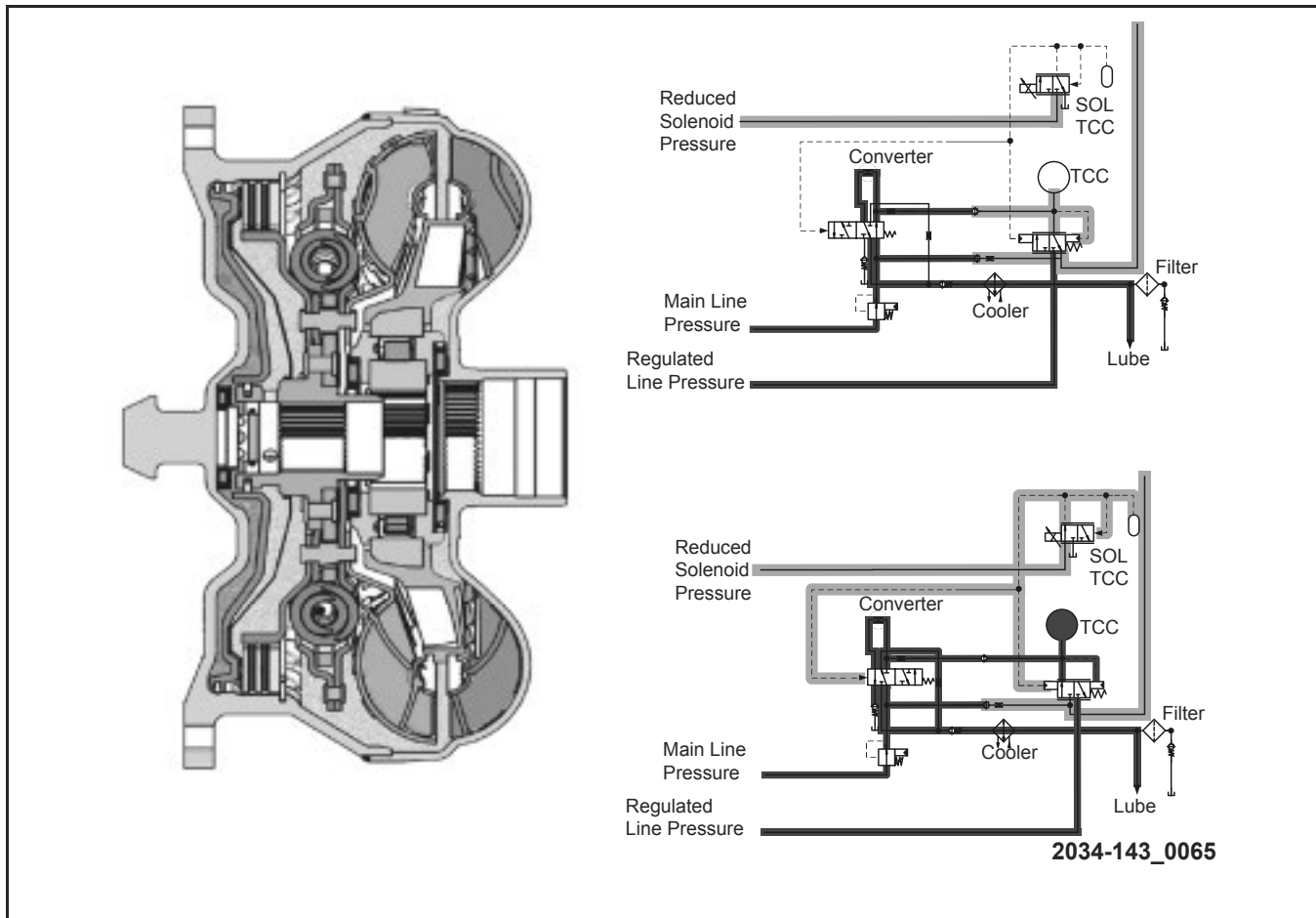

Figure 30 Torque Converter Clutch Control Circuits (8HP45/845RE shown)

When the TCC is off, the TCC apply piston is pushed to its default position by torque converter chamber pressure. The torque converter switch valve provides pressure for torque converter operation that has been regulated by the torque converter pressure regulator valve. After exiting the torque converter, fluid moves into the cooling and lubrication circuits.

When the TCC is on, the solenoid is energized and fluid is directed to the torque converter switch valve and TCC control valve. The TCC control valve directs fluid to the TCC and torque converter chamber. The torque converter switch valve directs fluid exiting the converter chamber to a secondary pressure retention valve to retain pressure in the converter. The torque converter switch valve also directs line pressure to the cooler and lubrication circuit.

The three-circuit design allows fluid to flow through the torque converter before going to the cooler, regardless of the TCC lockup state. This helps keep the torque converter cooler than a two-channel design.

TORQUE CONVERTER NOISE DIAGNOSIS

Torque Converter External Noise

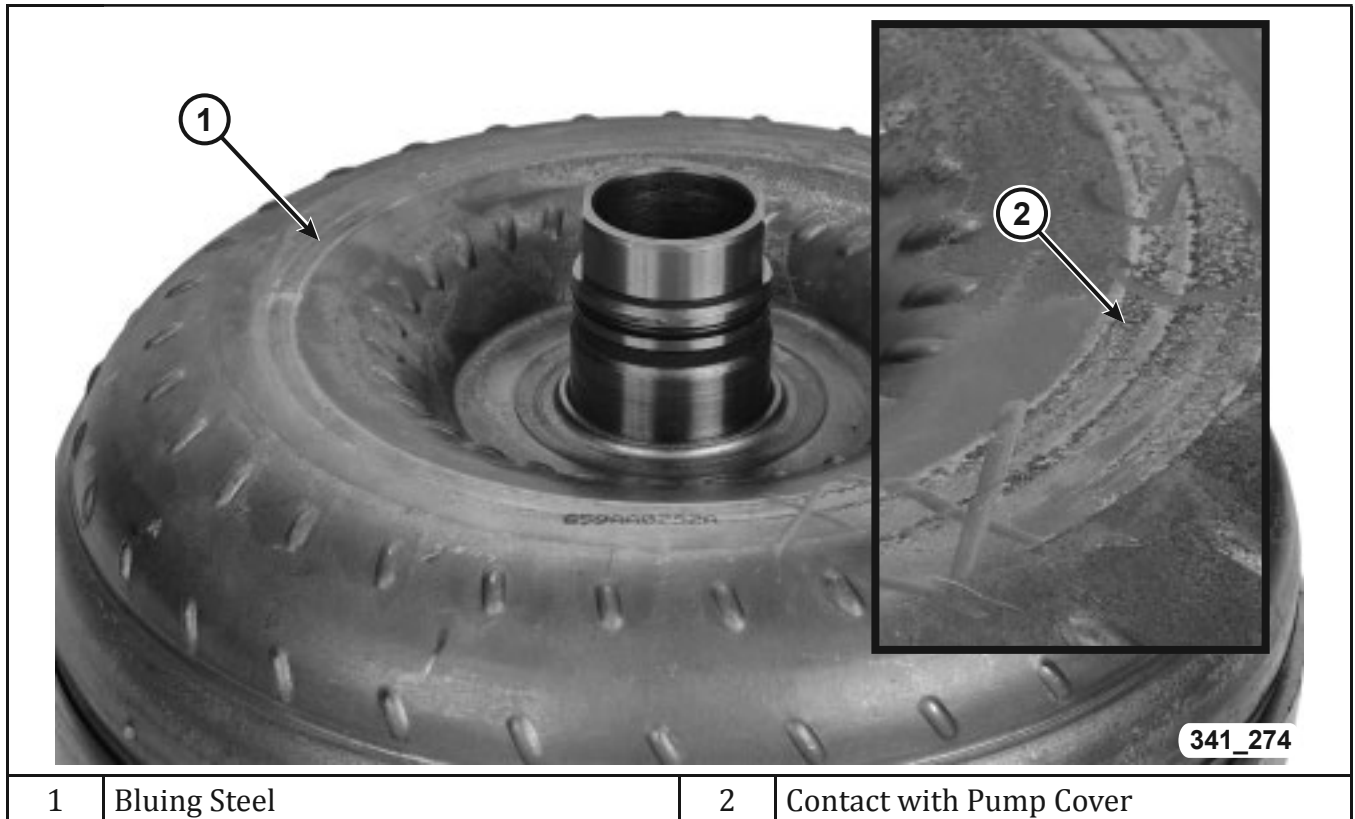

Figure 31 Torque Converter Abnormal Contact

Torque converter noise can be divided into either external or internal sources. Noise generated by external sources always follows the increase and decrease of engine rpm. The noise is present any time the engine is running.

Common sources of external torque converter noise include the following:

- Loose torque converter to flex plate bolts
- Torque converter contact with transmission case
- Fluid pump drive sprocket and chain
- Damaged front pump seal

Torque Converter Internal Noise - Park or Neutral

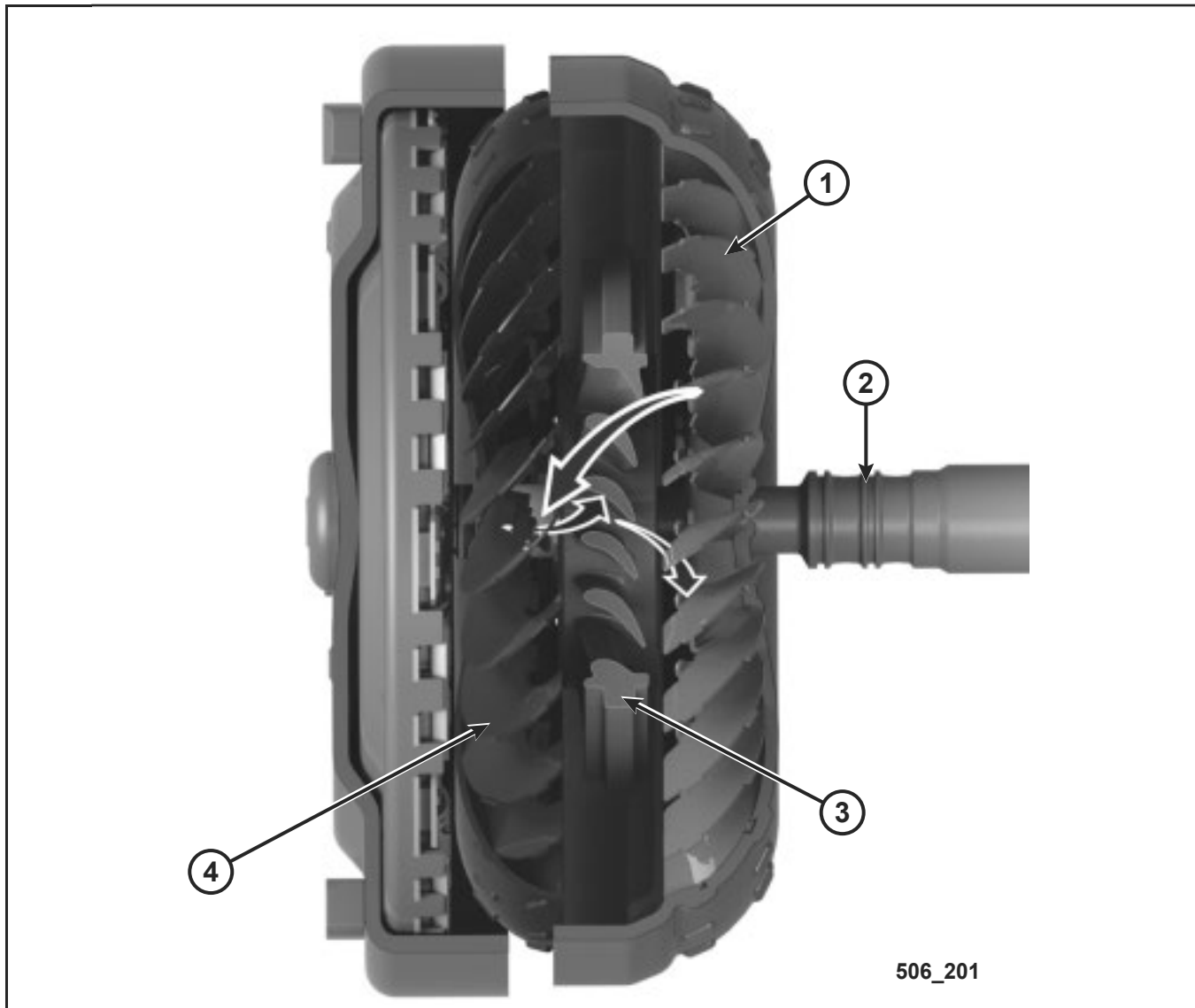

1	Engine Speed	3	Almost the Same as Engine Speed
2	Same as Engine Speed	4	Same as Engine Speed

Figure 32 Internal Noise Components Speed Relationships

Internal torque converter noise is often generated by the internal components as they rotate at different rates of speed. The noise is typically more intense under a load.

If the internal components are the source of a noise, the noise generally will not be present when the transmission is in Park or Neutral. In these ranges, all the components rotate at the same speed and no load is transferred to the turbine shaft.

If the noise is present in both Park and Neutral, the noise is likely external to the torque converter or is fluid pump related. It is also possible that components supporting or connected to the turbine shaft are generating any noise present in both Park and Neutral.

Torque Converter Internal Noise - Drive or Reverse

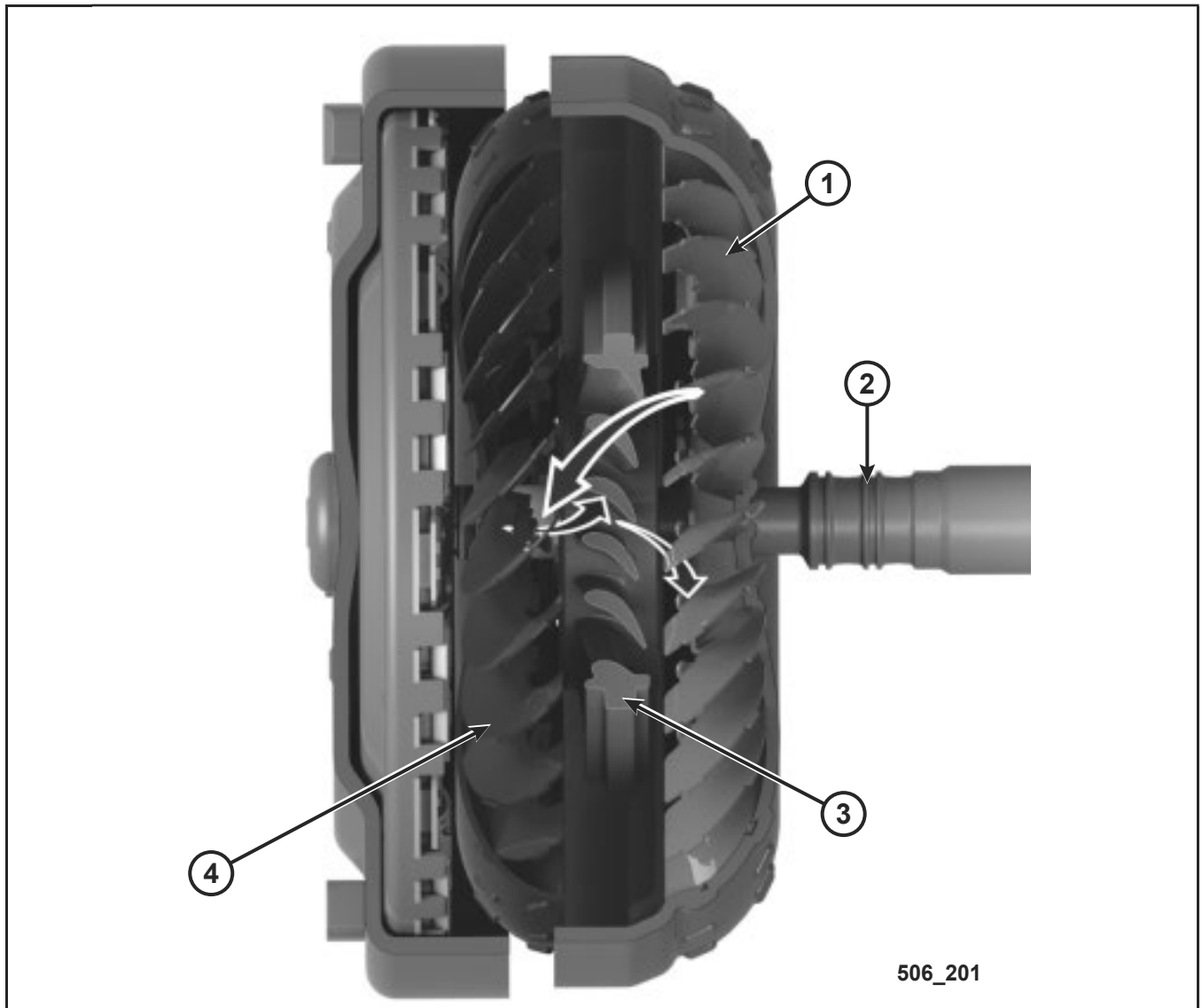

A	Brakes Applied/Vehicle Stopped	B	Vehicle Launch
1	Engine Speed	1	Engine Speed
2	Stopped Under Load	2	Stopped Under Load
3	Freewheeling	3	Freewheeling
4	Stopped Under Load	4	Stopped Under Load

Figure 33 Noise in Drive or Reverse Component Speed Relationships

The internal components of the torque converter are most likely to generate noise in Drive or Reverse. The different rotational speeds occurring within the torque converter cause the noise, typically due to damage or debris within the converter.

When the transmission is in Drive or Reverse with the vehicle stopped, the turbine assembly (including the released TCC) is held stationary as the impeller and torque converter cover rotate at engine speed. As the vehicle brakes are released and the torque converter begins torque multiplication, the noise continues.

Torque Converter Internal Noise - Cruise

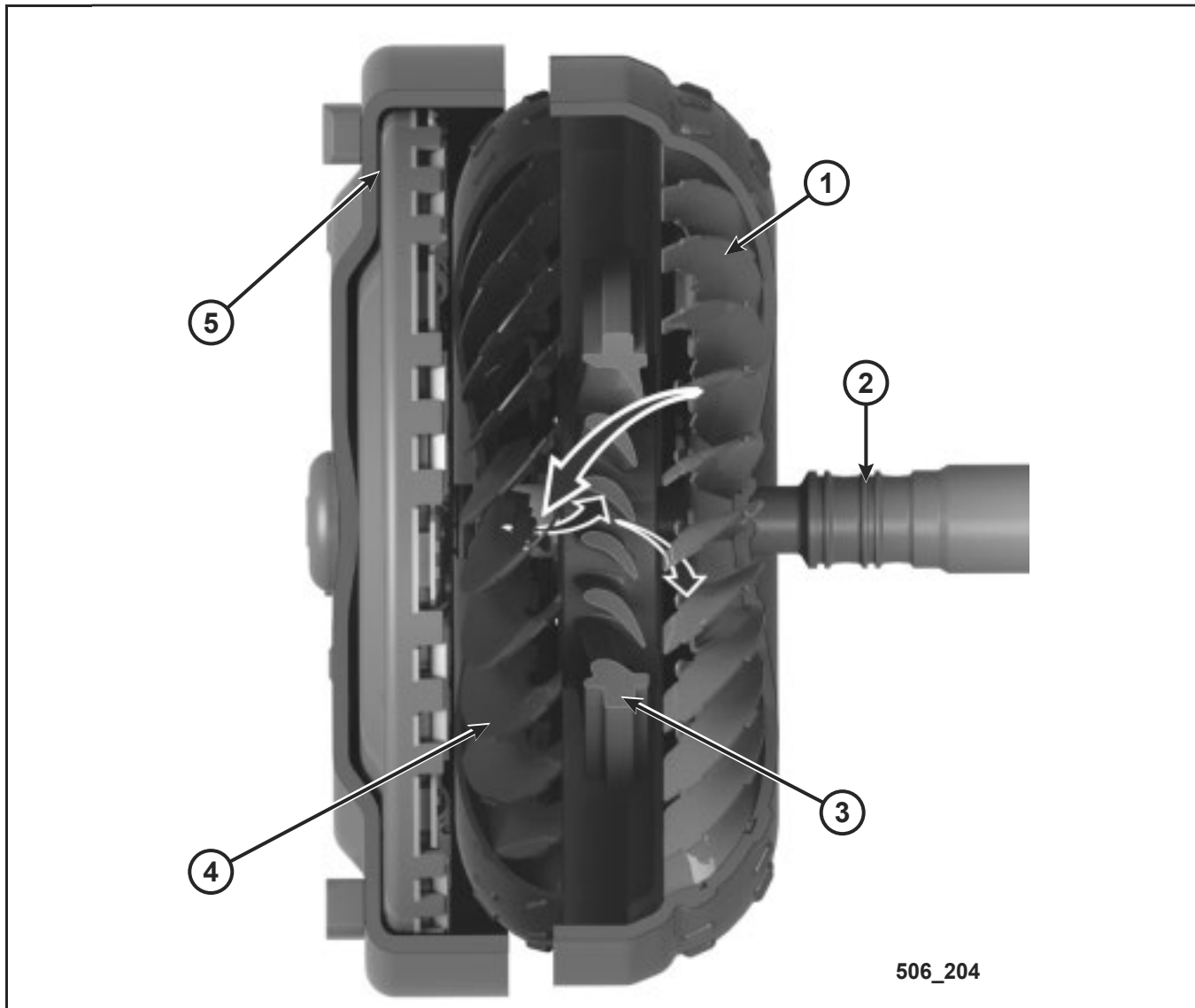

1	Impeller	4	Turbine
2	Turbine Shaft	5	Torque Converter Clutch
3	Stator		

Figure 34 Noise at Cruise Components

Noise generated within the torque converter often reduces in intensity as the vehicle approaches cruise speed and is eliminated when the TCC is fully applied. At both of these points, the internal components of the torque converter are either nearing or at the same rotational speed.

It is also possible for damage within the stator to only generate noise at cruise speeds. The noise is not present when vehicle is stopped or during launch because the stator is held and not rotating. However, when the stator begins to overrun, the noise starts. The noise is also present when the TCC is applied because the outer race of the overrunning clutch is rotating at the same speed as the turbine and impeller, and the inner race is held to a stop.

Torque Converter Internal Noise and Vibration - TCC Apply

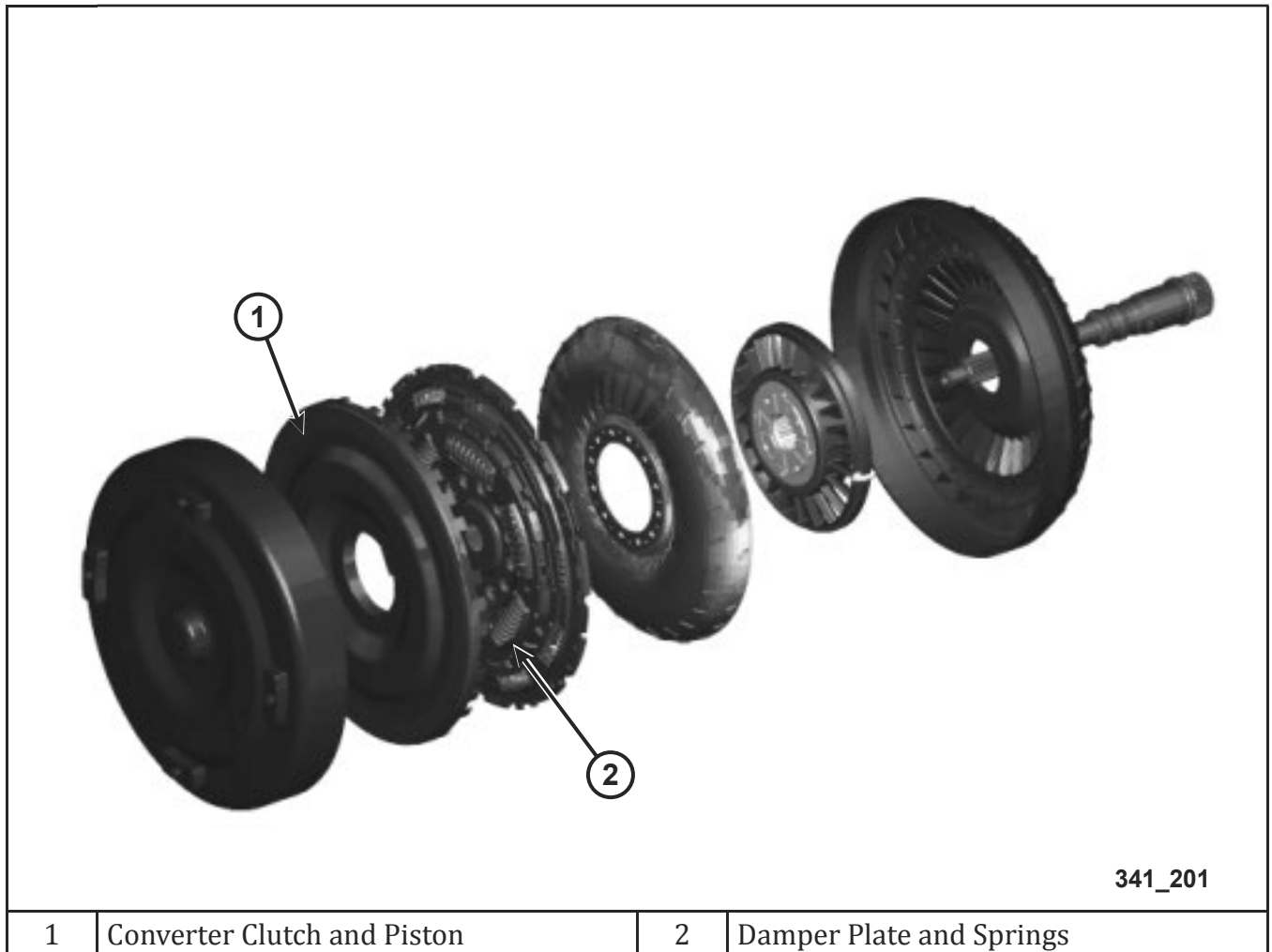

Figure 35 Torque Converter Clutch Noise and Vibration Components

In many cases, the application of the TCC eliminates noise generated within the torque converter because it forces the impeller, stator, and turbine to all rotate at the same speed. However, damage within the TCC can cause noise and vibration during application. Noise caused by this type of damage is not present when the TCC is released.

Most TCC assemblies include a spring damper assembly to soften the application of the TCC. If there is damage in the damper assembly, there will be noise during TCC application, and the noise will dissipate when the TCC is fully applied.

TRANSMISSION COOLING SYSTEM

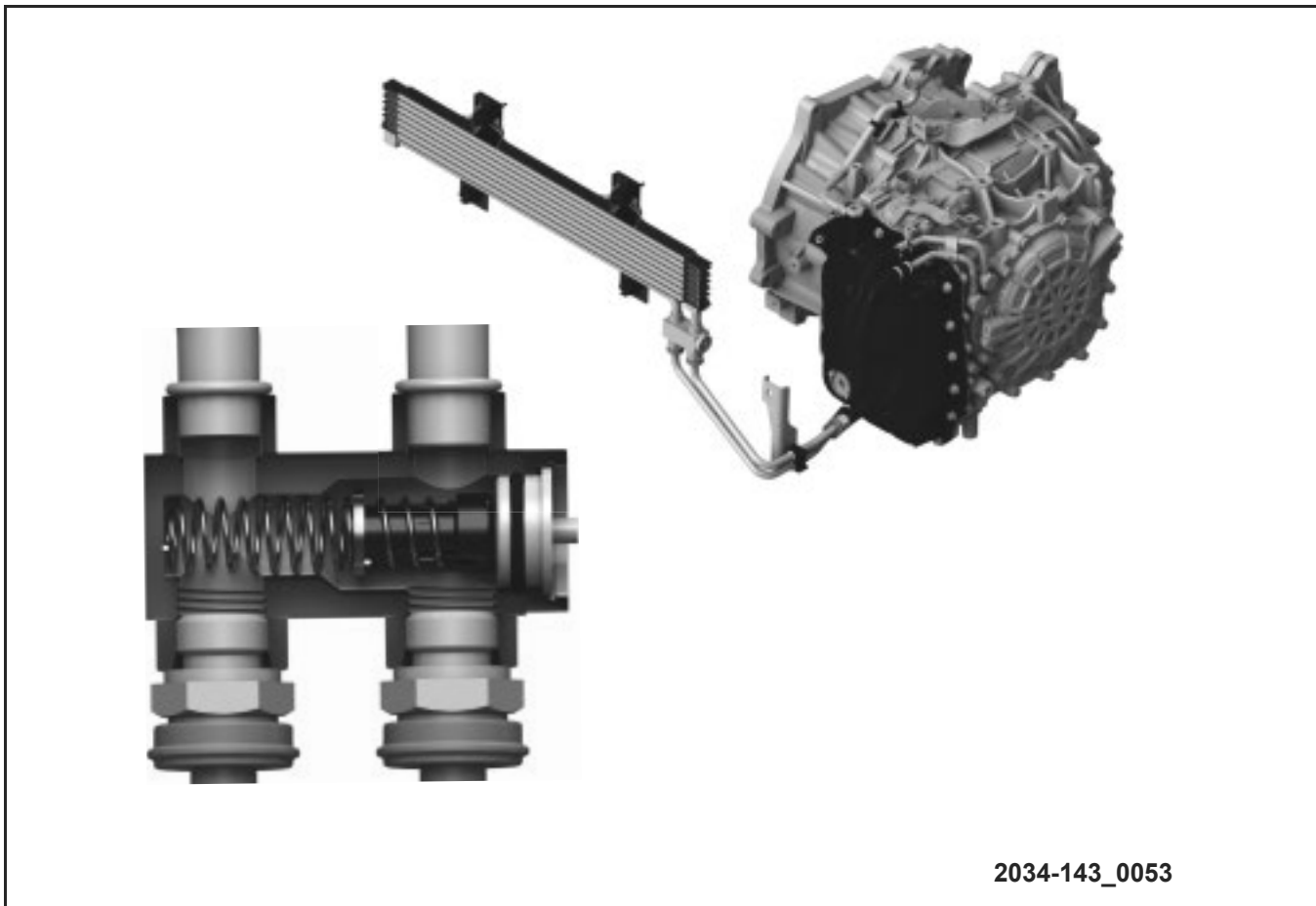

Figure 36 Cooler and Bypass Valve

Transmission coolers are designed to remove excess heat from the transmission fluid. The types of transmission cooling systems are:

- Single-pass parallel-path
 - Radiator in-tank (oil-to-water heat exchange)
 - Externally mounted (oil-to-water heat exchange)
- Double-pass parallel-path
 - Remote standalone (oil-to-air heat exchange), mounted in front of the radiator
 - Remote combo cooler (oil-to-air heat exchange), part of the air conditioning condenser

Single-Pass Parallel-Path Coolers

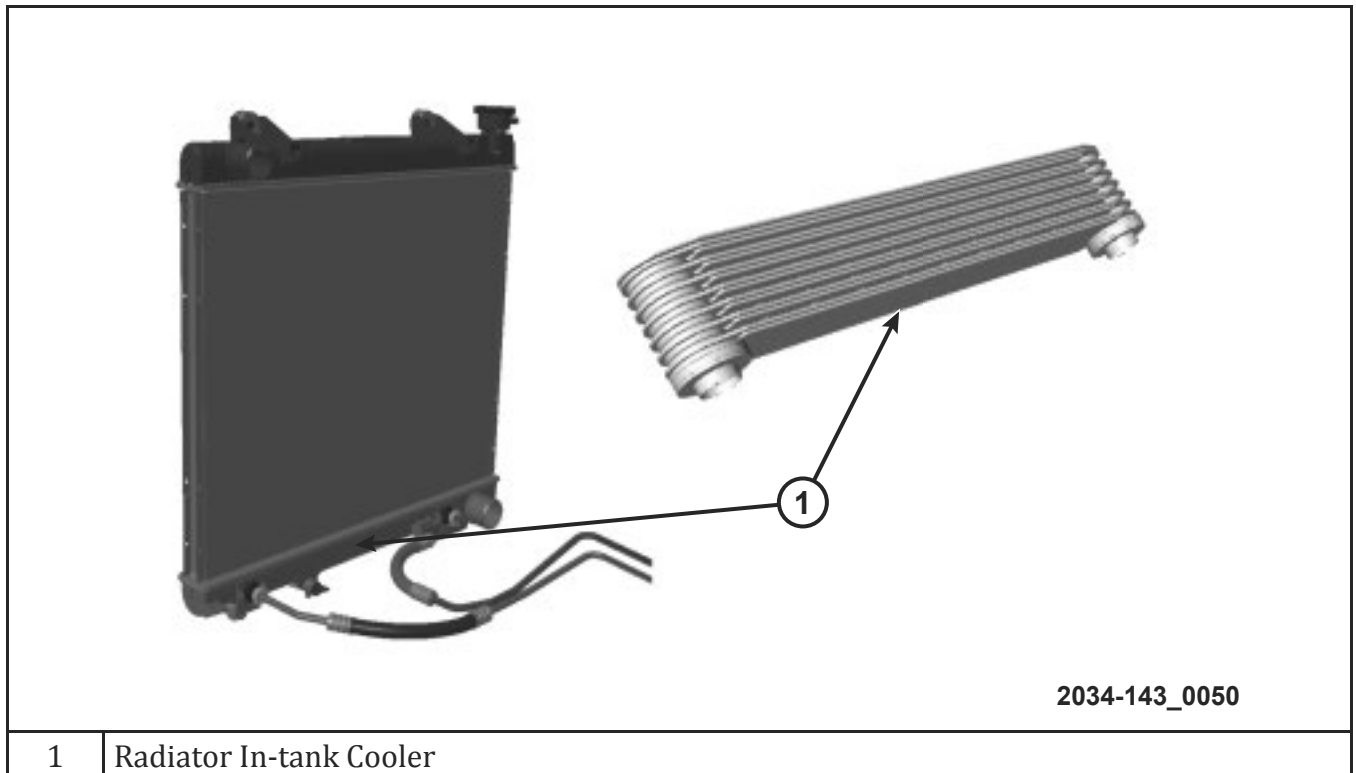

Figure 37 Radiator In-tank Oil-to-water Cooler

The radiator in-tank cooler uses a single-pass, parallel-path flow design. Fluid from the transmission flows into a single-pass cooler design at one end, across the cooler body, which is immersed in engine coolant, and then out the other end.

In-tank coolers consist of a series of plates that carry the transmission fluid through the engine coolant. This transfers heat either out of or into the fluid. The number of plates varies by application. The higher the number of plates, the more heat transfer takes place. Heavy-duty powertrain packages use approximately seven plates. Cooling (and heating) of the fluid takes place by oil-to-water heat exchange.

Bolt-on-Cooler

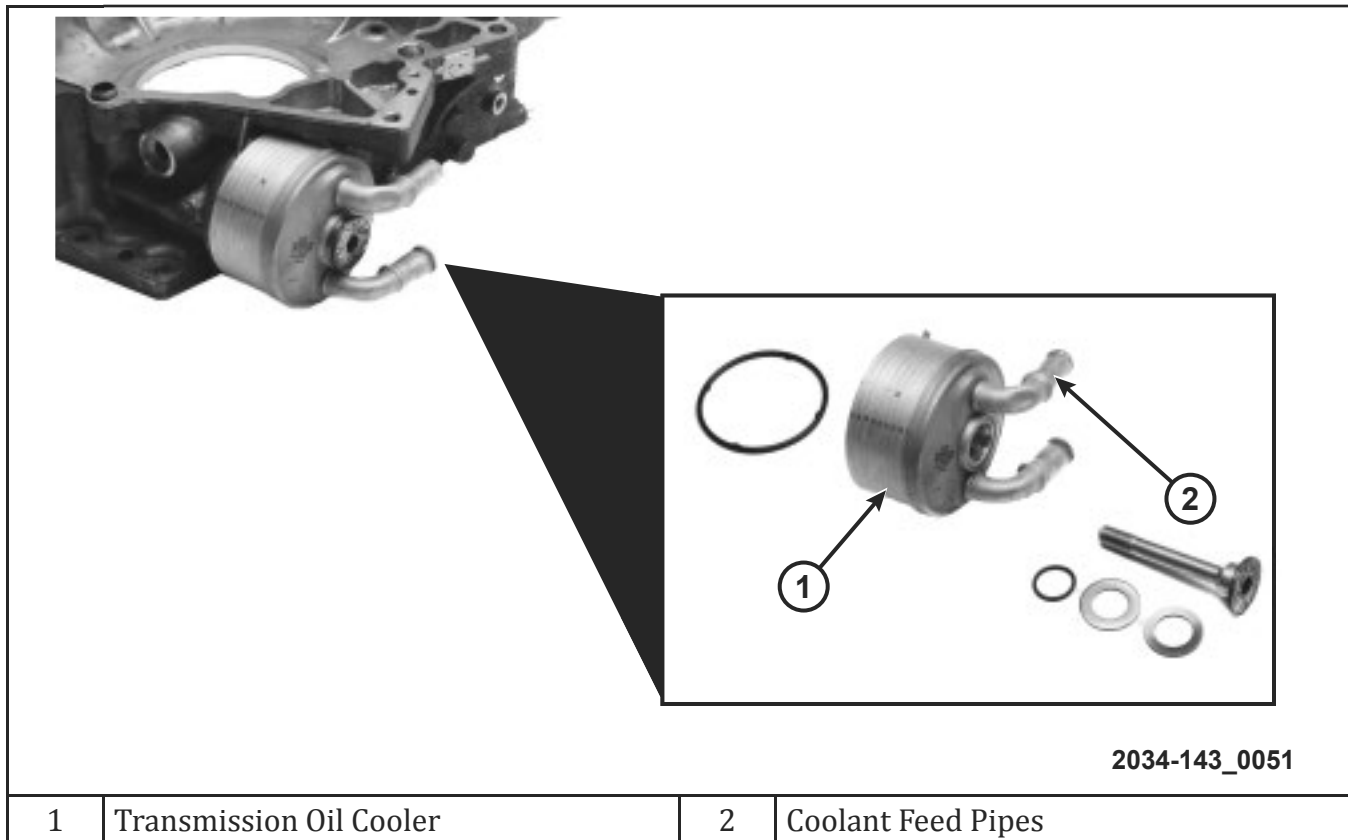

Figure 38 External Bolt-on Oil-to-water Cooler

Externally mounted transmission oil coolers attach to the transmission case and have engine coolant routed to them through hoses and pipes. The cooler transfers heat from the transmission oil to the engine coolant to cool the transmission. Likewise, engine coolant typically warms up faster than the transmission oil, so the transmission warms up faster.

The industry trend is to heat the transmission oil as quickly as possible. A transmission operating within a specified temperature range provides many advantages. One of the advantages is that the torque converter clutch can apply sooner and provide better fuel economy. Another advantage is that the fluid viscosity changes when it warms up, which improves the shift quality.

Oil-to-Air Cooler

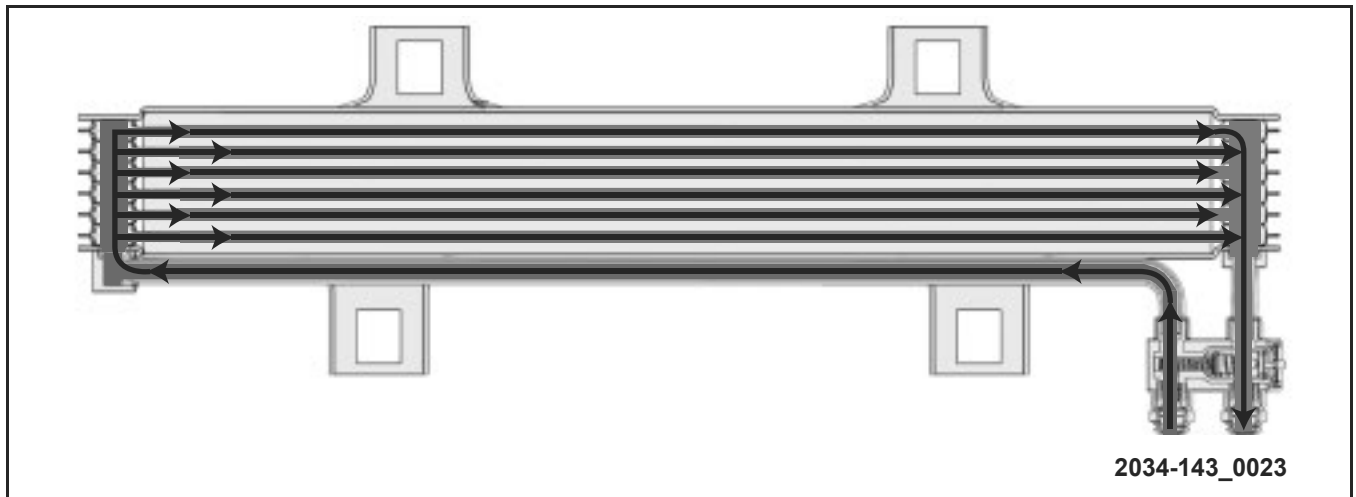

Figure 39 Single-pass Oil-to-air Standalone Cooler (6F24 Dodge Dart shown)

Double-Pass Parallel-Path Design



Figure 40 Double-pass Parallel-path Cooler Construction

Some vehicle powertrain combinations use combination transmission oil coolers. Combination transmission oil coolers use a double-pass parallel-path design and are available in two versions: standalone and combo, which combines transmission cooler function with the air conditioning (A/C) condenser for tighter packaging.

Cooling of the transmission fluid takes place by way of oil-to-air heat exchange.

In a double-pass parallel-path design, fluid flows across the cooler through plates, is turned around, and flows across the cooler a second time before it is returned to the transmission.

Torque Converter and Temperature Control

Double-Pass Combination Cooler

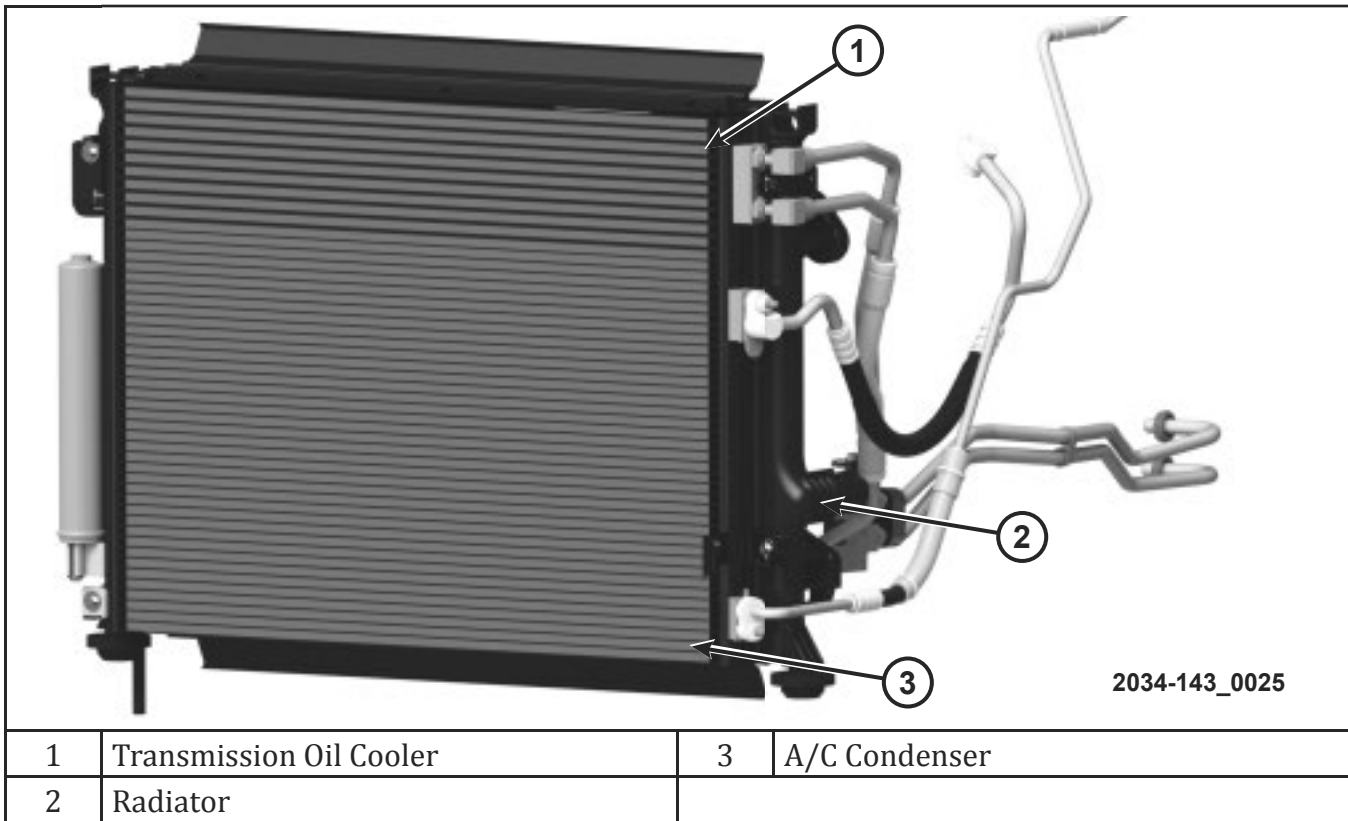

Figure 41 Transmission Remote Combo Cooler (LX shown)

Double-Pass Stand-Alone Cooler

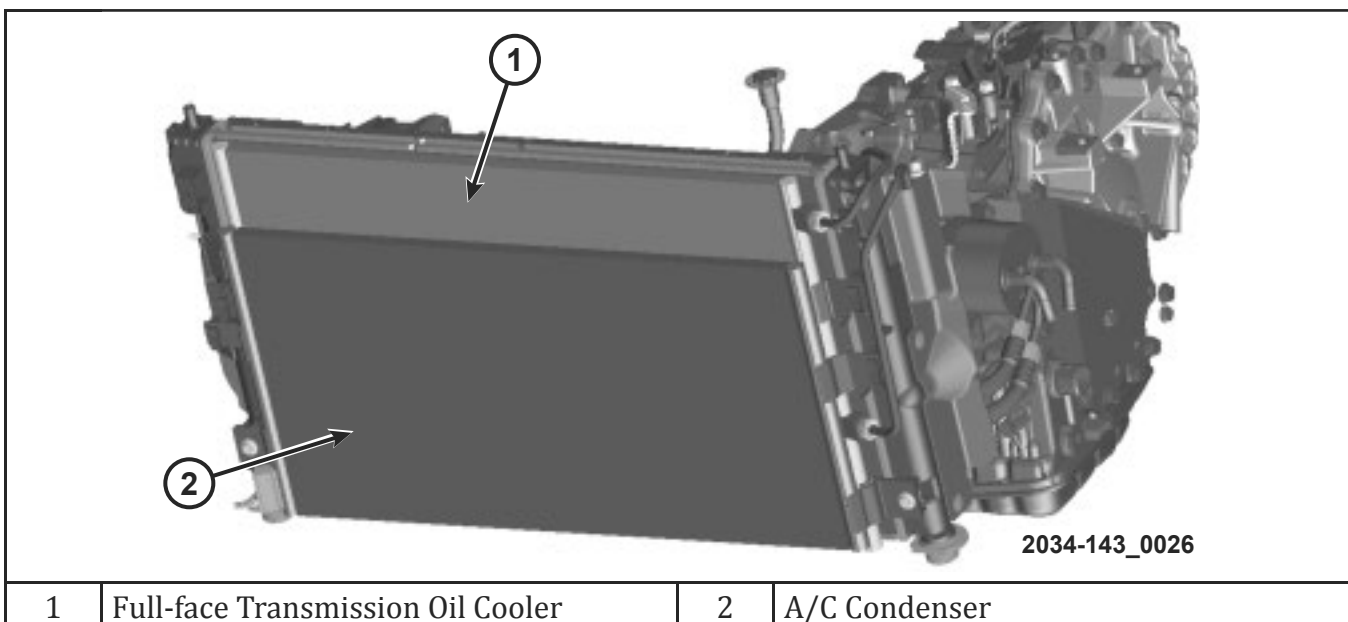

Figure 42 Stand-alone Transmission Oil Cooler

COOLING SYSTEM HYDRAULIC OPERATION

Pressure Bypass Systems

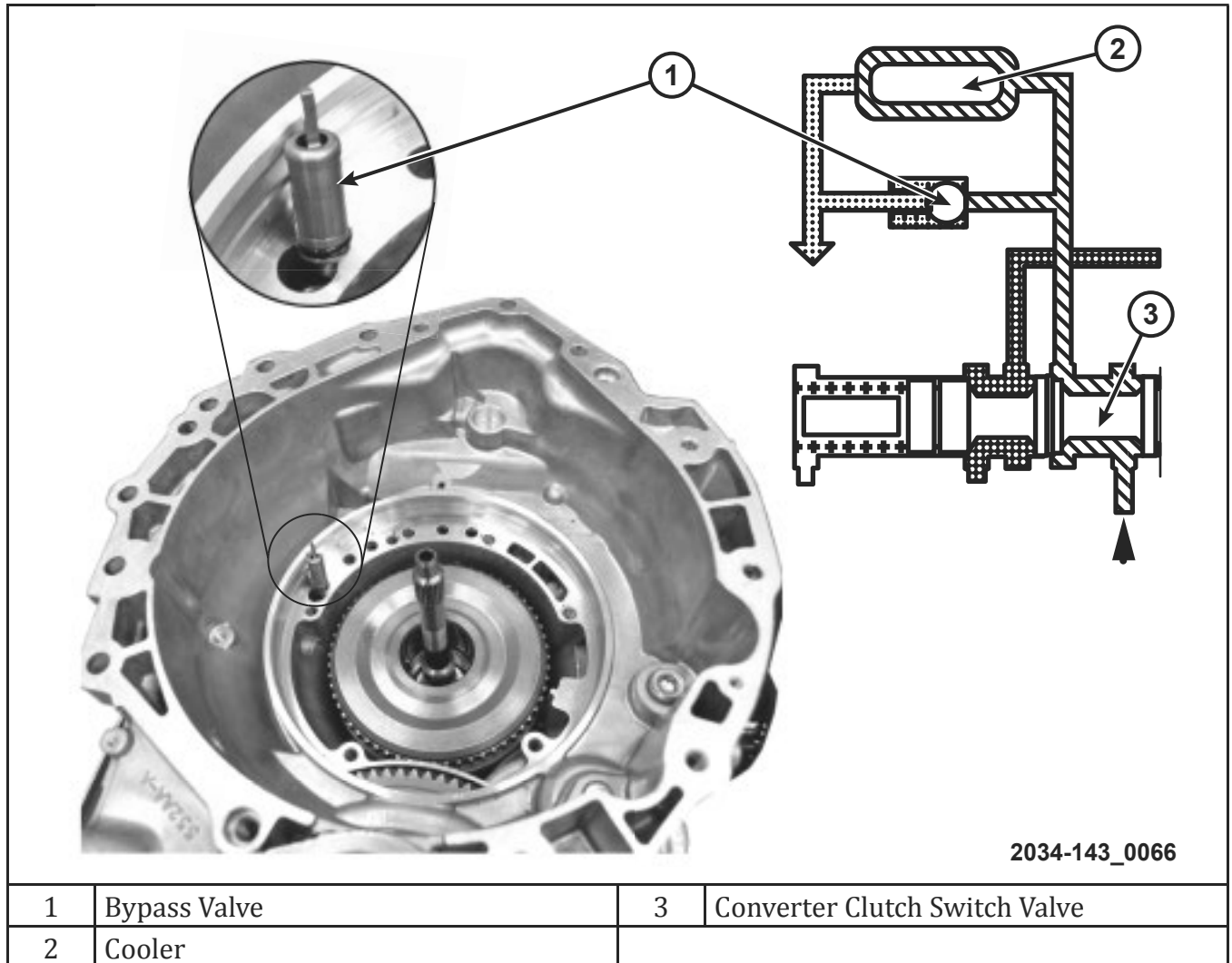

Figure 43 Oil Cooler Pressure Bypass Valve (62TE shown)

Some vehicles use a pressure bypass valve that is internal to the transmission. This valve is located in the transmission case behind the oil pump and connects the oil cooler supply and return circuits with a spring-loaded check ball.

The valve is designed to bypass the cooler feed circuit at a specific pressure differential between the cooler inlet and outlet circuits. Fluid bypasses the cooler until the pressure differential falls below the specification.

Fluid that bypasses the cooler is redirected to the transmission lubrication circuit to prevent geartrain fluid starvation.

NOTE: Replace the cooler bypass valve if transmission failure has occurred.

Torque Converter and Temperature Control

Pressure Bypass Systems (continued)

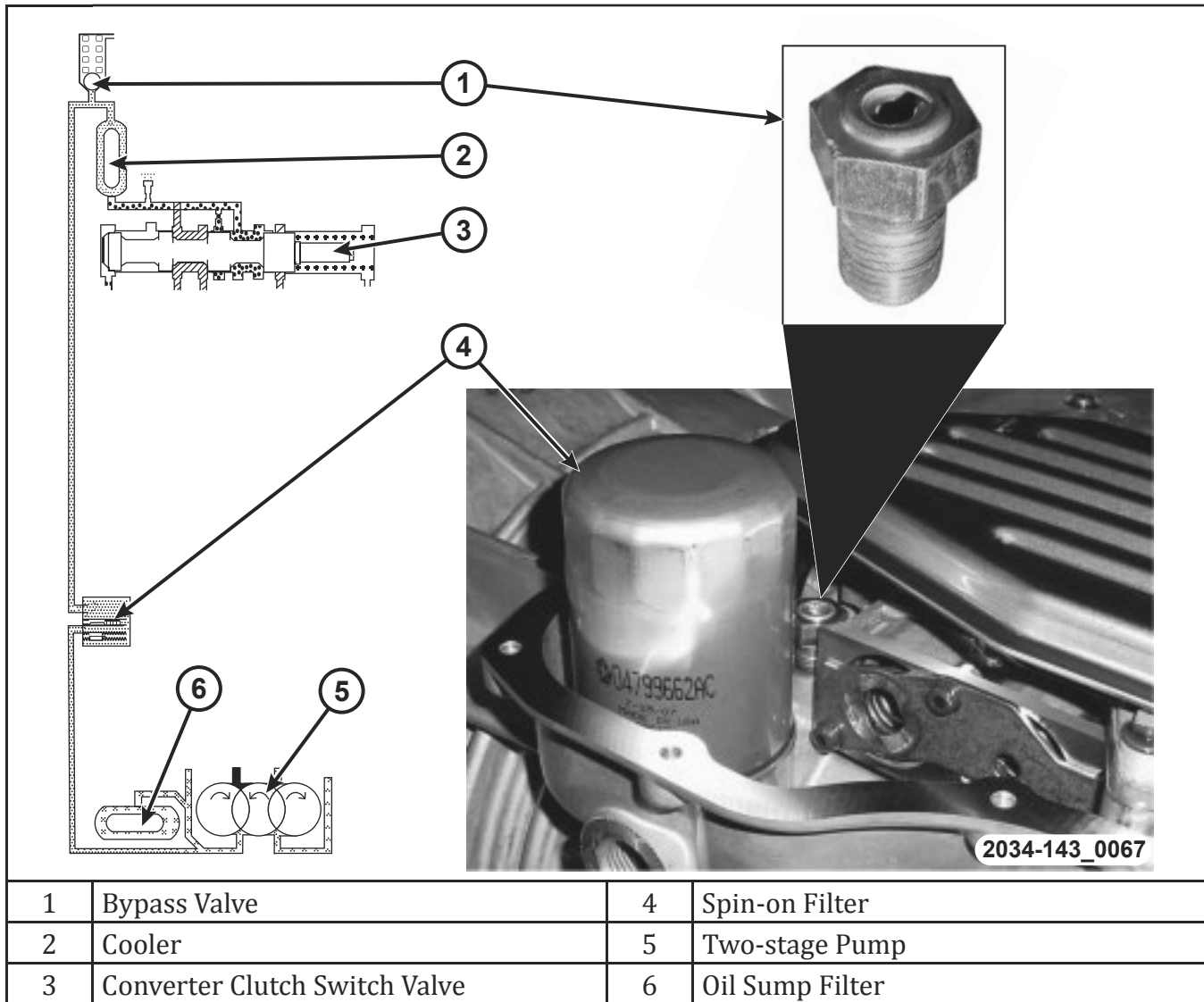

Figure 44 Downstream Pressure Bypass Circuit (RFE shown)

Some cooler hydraulic circuits include a return filter between the cooler outlet and the oil pan (sump). This system is similar to the bypass type, but adds a relief valve that limits pressure in the hydraulic circuit between the cooler outlet and the return filter. If the return filter is plugged, the relief valve sends the fluid from the cooler back to the sump.

Thermal and Pressure Bypass Systems

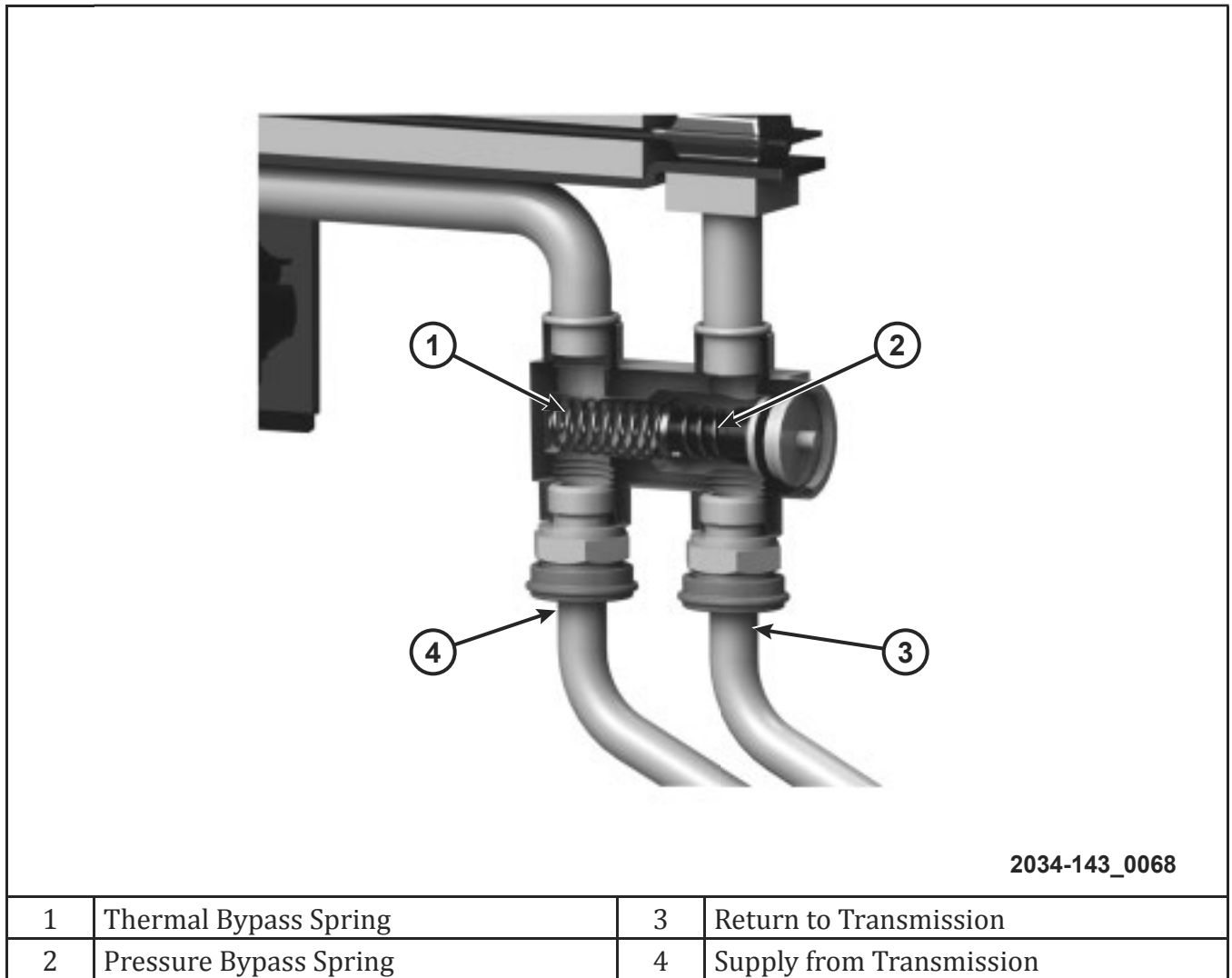

Figure 45 Thermal and Pressure Bypass Valve

Some vehicles use a thermal-style external bypass valve to bypass the transmission cooler. This design differs from the pressure style because fluid bypasses the cooler until a certain fluid temperature is reached.

Cold Operation

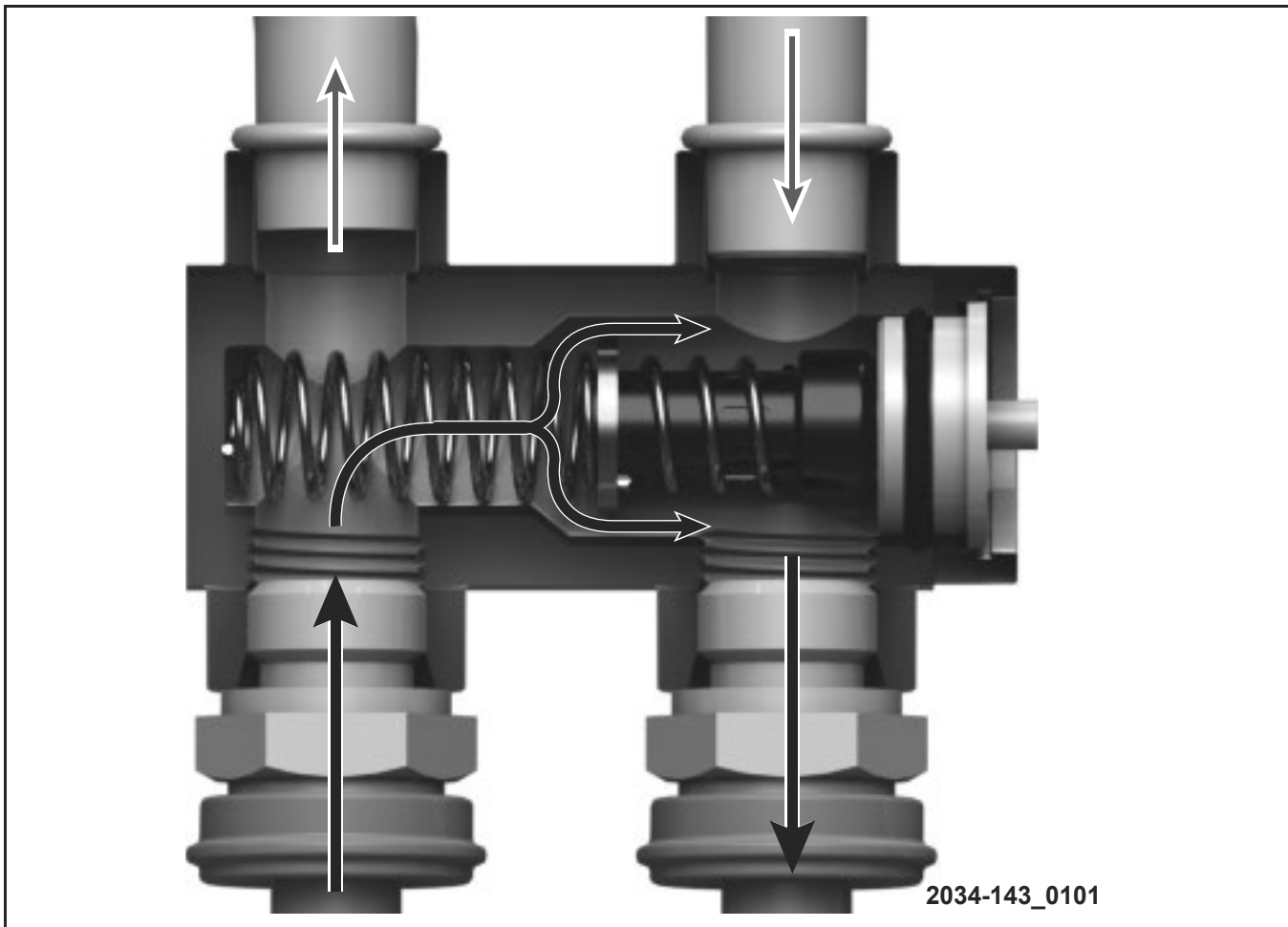

Figure 46 Thermal and Pressure Bypass Valve (cold)

When the transmission fluid is cold, the fluid bypasses the cooler, allowing it to be heated faster to operating temperature. Bypassing the cooler promotes a quicker transmission warm-up. This design also minimizes parasitic losses associated with operating while the fluid is cold.

Hot Operation

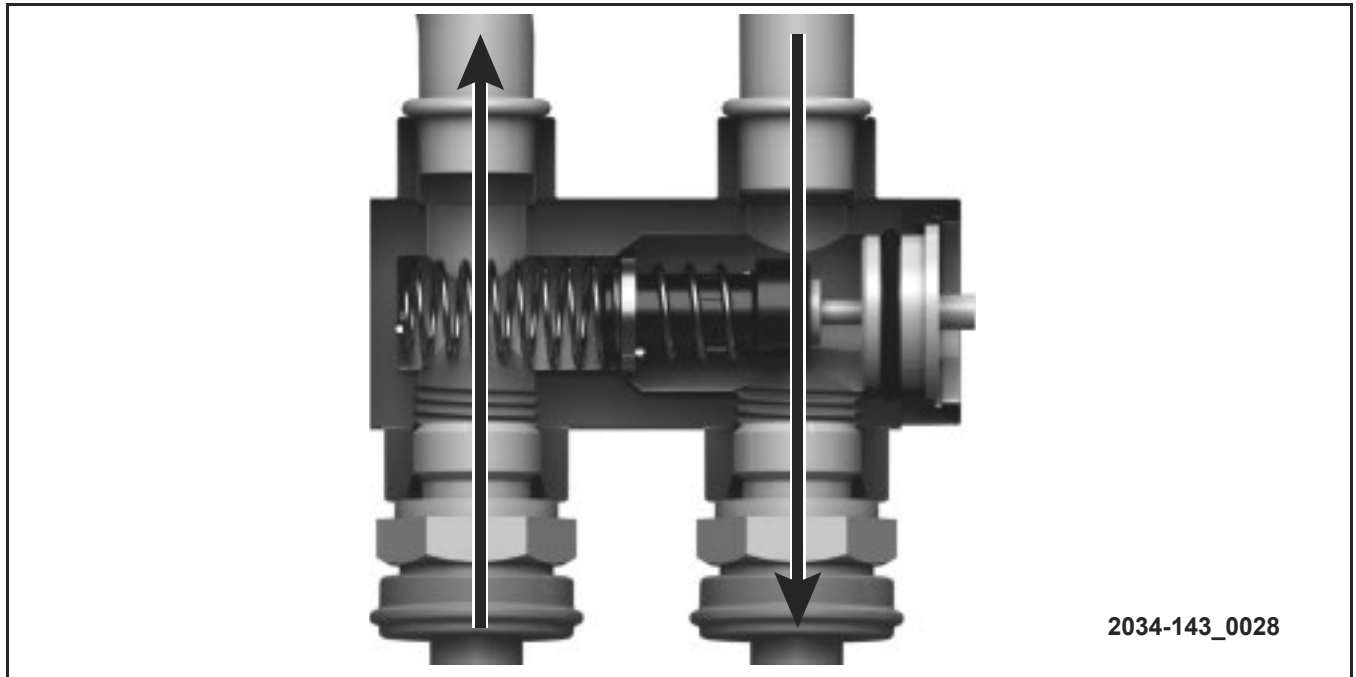

Figure 47 Thermal and Pressure Bypass Valve (hot)

When transmission fluid exceeds a specified temperature, fluid is sent to the oil cooler to remove excess heat. The thermal bypass in this example starts to move at 70 °C (158 °F). The valve is fully seated at 85 °C (185 °F).

There is a wax pellet inside the thermal element that expands to move the plunger rod outward, moving the body of the valve to the left to seat, and forcing the fluid to travel through the cooler.

Pressure Bypass Operation

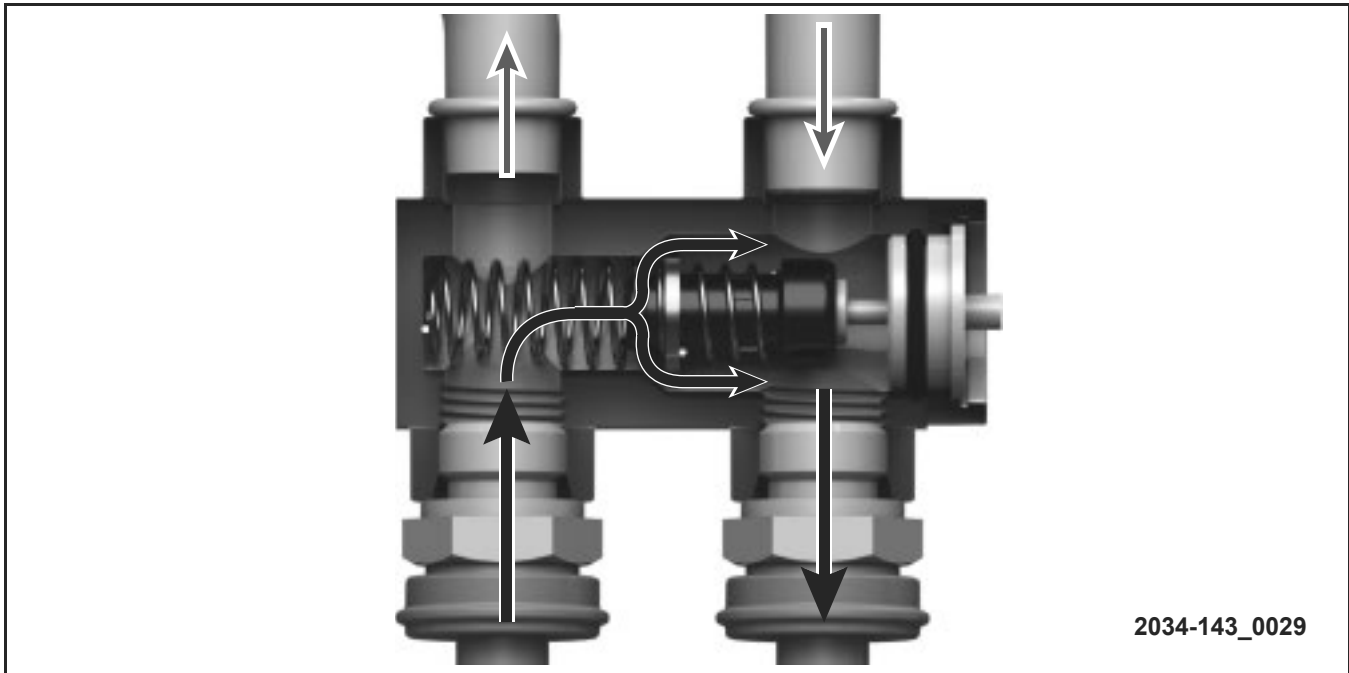

Figure 48 Thermal and Pressure Bypass Valve (pressure bypass)

Additionally, there may be a pressure bypass feature. When fluid is hot enough to be sent to the cooler, a calibrated spring-loaded bypass feature allows cooler bypass in the event of a plugged or restricted cooler. This prevents transmission lubrication circuit starvation.

This pressure-based bypass feature activates when the pressure drop across the valve reaches a specified set-point.

Thermal Bypass Valve Tube Type

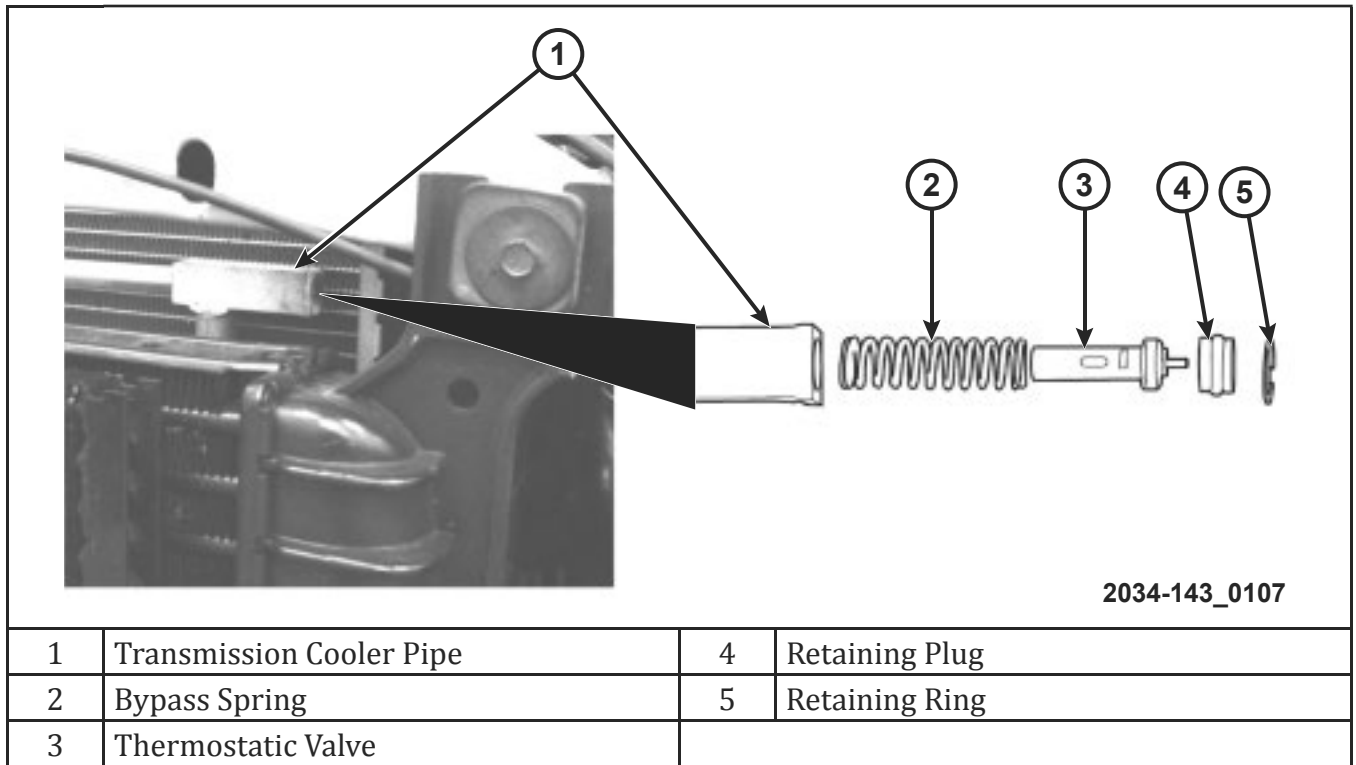

Figure 49 Thermal Bypass Valve

On vehicles equipped with Aisin AS68RC and RFE transmissions, a thermostatic bypass valve is also used. This bypass valve is external to the transmission and can be found in the standalone air-to-oil cooler.

When the transmission fluid is cold, the fluid bypasses the cooler, allowing it to be heated faster to operating temperature. When transmission fluid reaches a specified temperature, the bypass seats and fluid is sent to the cooler to be cooled.

TRANSMISSION OIL HEATER SYSTEM

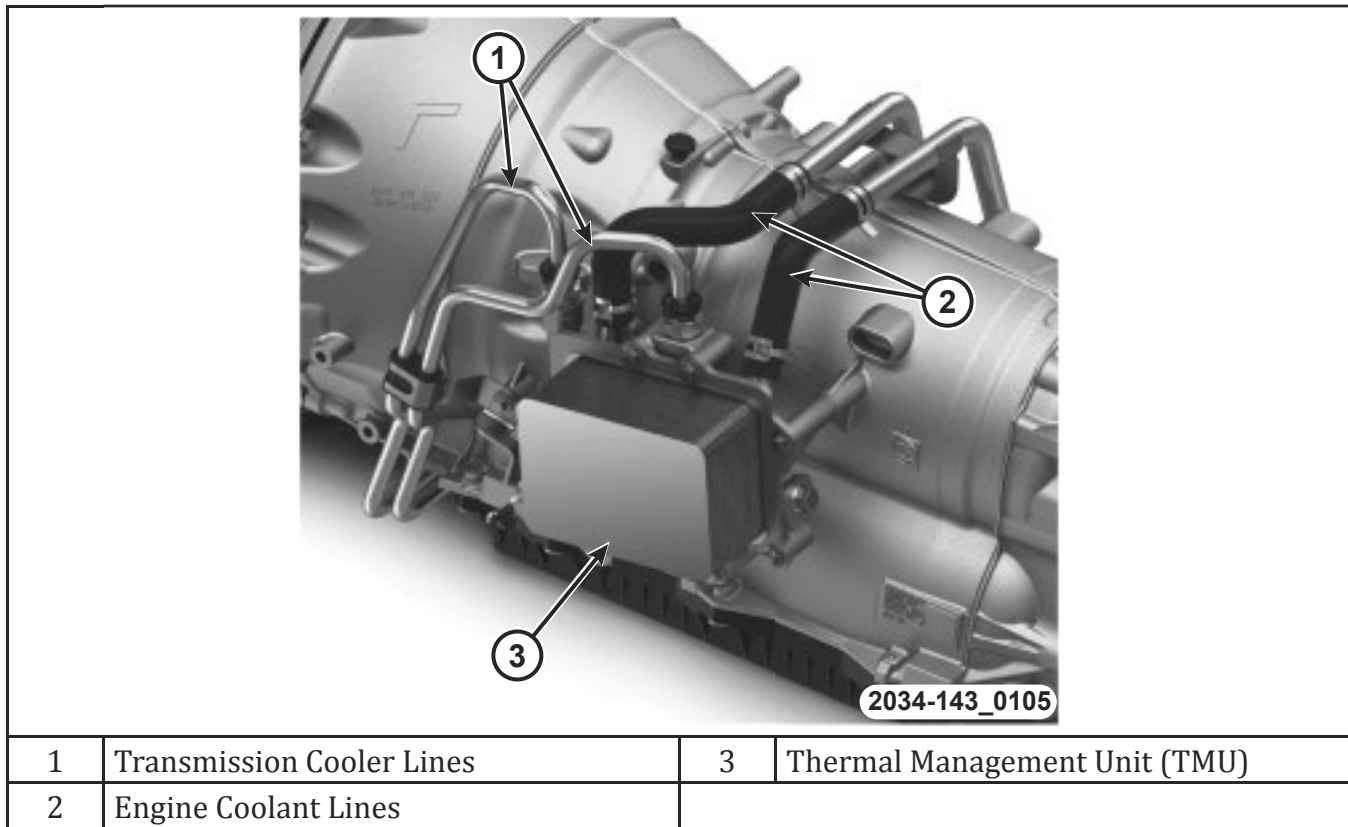

Figure 50 Transmission Heater System (8HP45 shown)

The purpose of the transmission thermal management system is to keep the transmission fluid at its optimal operating temperature range. This is accomplished by directing coolant flow not required for cabin heat to the thermal management unit (TMU). Coolant flow is directed by means of a pulse-width-modulated ball valve located upstream of the cabin heater coolant supply.

The TMU is an assembly containing an oil-to-water heat exchanger and a thermal bypass valve. The coolant that is sent from the three-way valve warms the transmission fluid in order to get it up to the ideal operating temperature range. When the transmission oil is sufficiently warm, the three-way valve stops diverting engine coolant to the transmission.

When the transmission fluid reaches its upper temperature limit, the integrated thermal bypass valve directs flow to the transmission oil cooler. Instead of connecting directly to the transmission ports, the transmission cooler lines plug into the quick-connect fittings on the TMU.

Coolant Bypass Valve

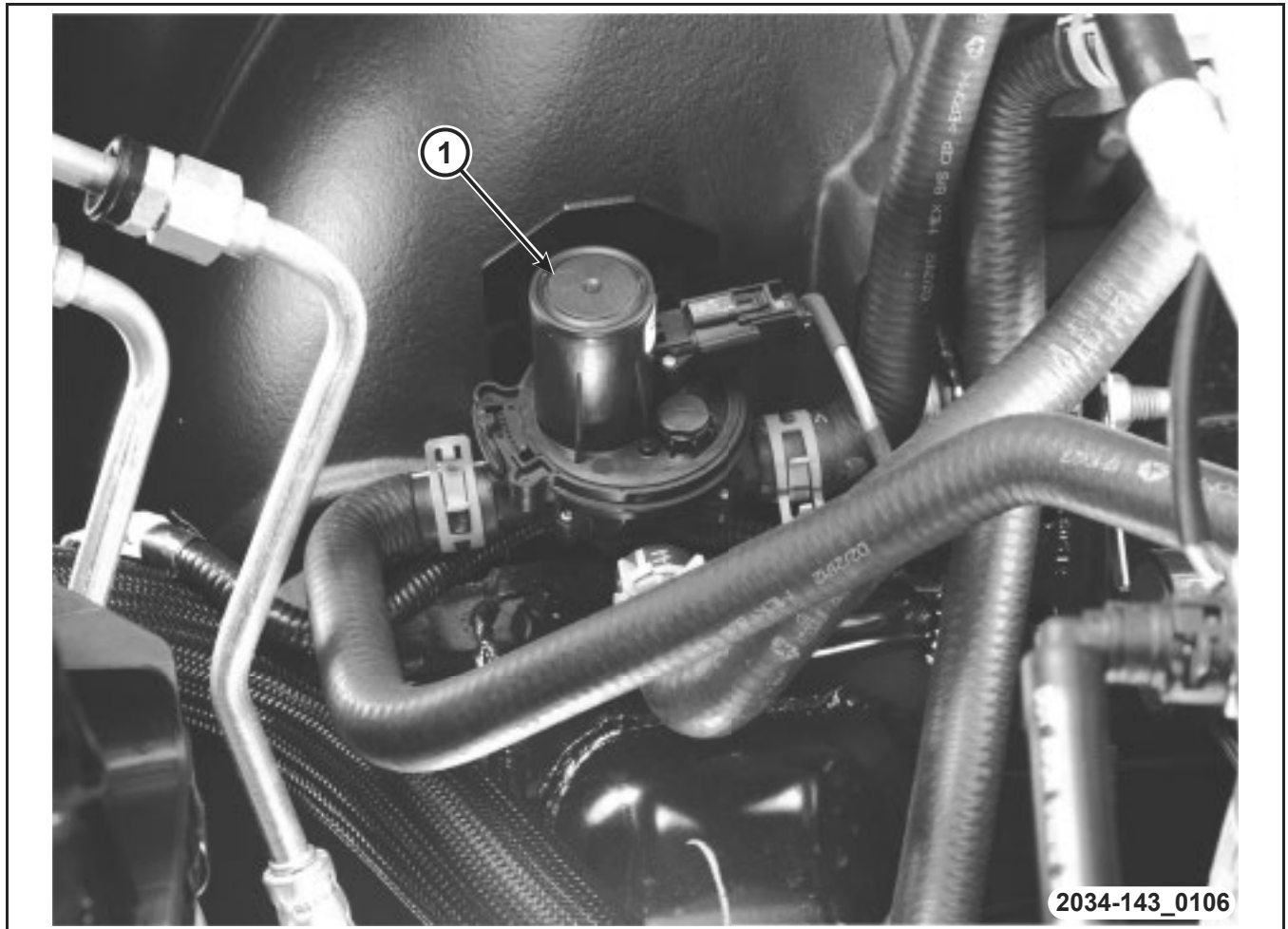

1	Coolant Flow Control Valve
---	----------------------------

Figure 51 Three-way Coolant Flow Control Valve

Instead of sending coolant from the engine directly to the heater core, the coolant first goes into the coolant bypass valve inlet port. The coolant valve receives a signal from the engine controller directing it to turn the ball valve in accordance with heater demand.

Special consideration is required any time the cooling system is opened on systems that include a three-way coolant bypass valve. When refilling the system to ensure that all air pockets are properly purged from the system.

Torque Converter and Temperature Control

Notes: _____

DEMONSTRATION 2 TORQUE CONVERTER COMPONENTS

Instructions: This demonstration ensures familiarity with the components of the torque converter. The demonstration page contains key questions on the topic that will be covered by the instructor.

1. What are the purposes of a torque converter?

2. What connects the engine to the torque converter?

3. What allows the engine to drive the transmission fluid pump?

4. What torque converter internal component is always connected to the engine?

5. What torque converter internal component connects to the transmission input shaft?

Torque Converter Components

6. Where are the thrust bearings located in the torque converter?
-
7. What component is located between the impeller and turbine?
-
8. What torque converter component provides a mechanical connection between the engine and transmission and eliminates the fluid coupling?
-
9. What component of the torque converter generally contains the damper springs?
-
10. What transmission component provides connection of the stator to the transmission case?
-



ACTIVITY 2 TORQUE CONVERTER MECHANICAL DIAGNOSIS

TASK ONE: SLUGGISH VEHICLE LAUNCH

Instructions: To diagnose a sluggish vehicle launch concern, identify the related components, learn how they work together, and then perform an initial diagnosis of the concern.

COMPONENTS

1. Identify the components of the torque converter in the table below the transmission cross-section image.

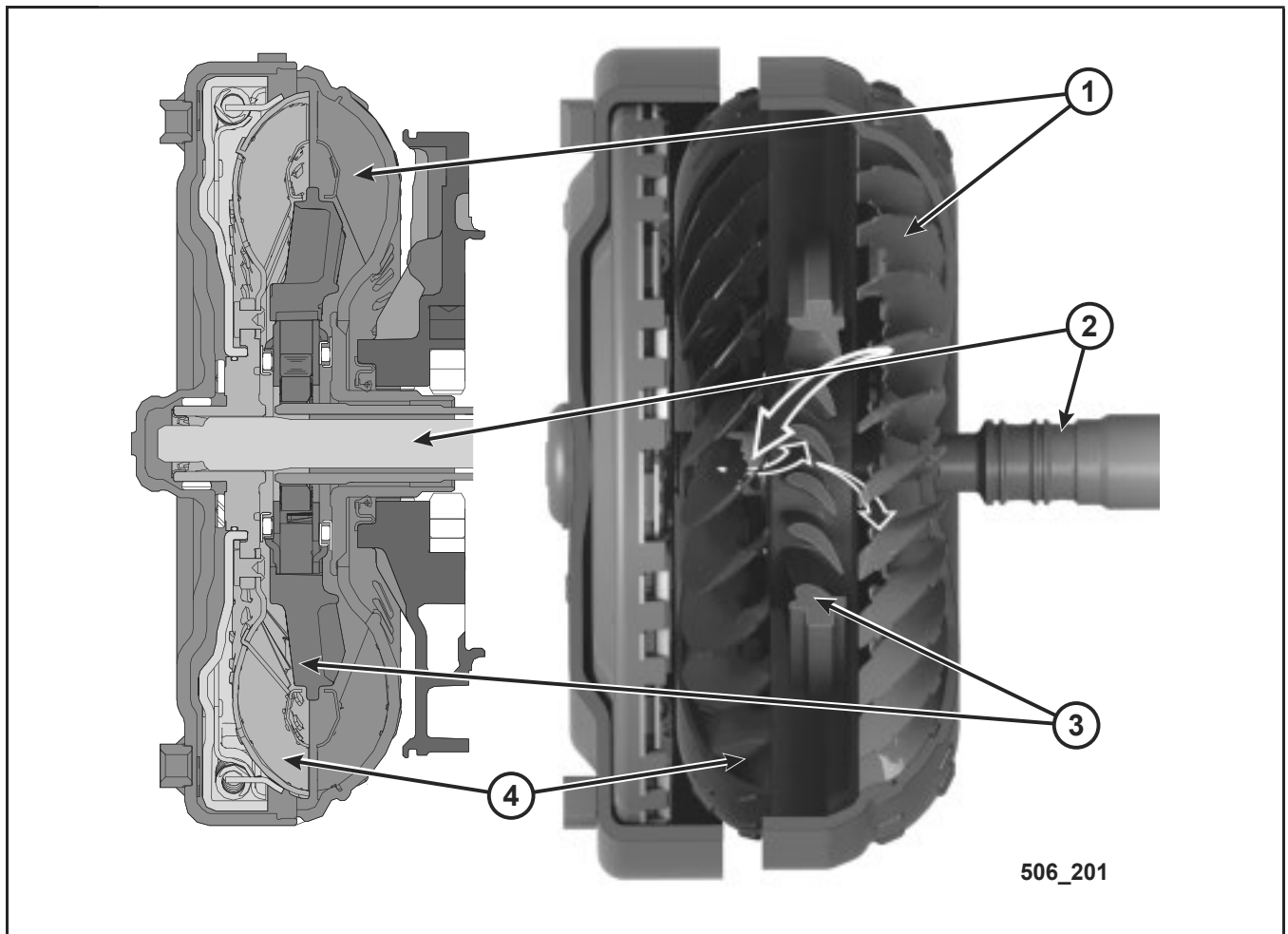

1		3	
2		4	



Torque Converter Mechanical Diagnosis

NORMAL OPERATION

Instructions: Identify internal operation of the torque converter using the [62TERecording1.xml](#) flight recording.

2. Go to 8.0 seconds in the recording.

Data Item	Fill in the Value Below from the Recordings
PRNDL Code	
Engine Speed	
Turbine Speed	
Torque Converter Slip	

- a. Why is the turbine speed not 0 rpm?
-
-



3. Go to 15.0 seconds in the recording.

Data Item	Fill in the Value Below from the Recordings
PRNDL Code	
Engine Speed	
Turbine Speed	
Torque Converter Slip	

4. Why is engine speed so much greater than turbine speed?
-

5. Go to 38.0 seconds in the recording.

Data Item	Fill in the Value Below from the Recordings
PRNDL Code	
Engine Speed	
Turbine Speed	
Torque Converter Slip	

a. Why is the turbine speed not 0 rpm?

6. Go to 54.5 seconds in the recording.

Data Item	Fill in the Value Below from the Recordings
PRNDL Code	
Engine Speed	
Turbine Speed	
Torque Converter Slip	

b. Why is there a large speed difference?



Torque Converter Mechanical Diagnosis

DIAGNOSIS

Instructions: Answer the following questions related to diagnosing a vehicle that has a sluggish vehicle launch.

7. What torque converter mode of operation is required to assist in the launch of the vehicle? Circle/check mark the correct answer.

<input type="checkbox"/>	Torque multiplication	<input type="checkbox"/>	Neutral
<input type="checkbox"/>	Cruise	<input type="checkbox"/>	

8. Which component is critical for this mode of operation?
-

9. What type of component failure would you expect for a vehicle that has a sluggish vehicle launch? Circle/check mark the correct answer.

<input type="checkbox"/>	Stator stuck (no rotation)	<input type="checkbox"/>	Stator freewheels at all times
--------------------------	----------------------------	--------------------------	--------------------------------

10. If this component was not operating correctly, what would you expect to see on the flight recording?
-

11. If the component was failing, could it be replaced?
-

12. Additionally, what non-transmission fault could also cause a sluggish vehicle launch?
-



TASK TWO: POOR VEHICLE PERFORMANCE AFTER LAUNCH

Instructions: To diagnose a poor vehicle performance after launch concern, first identify the related components, learn how they work together, and then perform an initial diagnosis of the concern.

NORMAL OPERATION

Instructions: Identify the internal operation of the torque converter using the [62TERecording2.xml](#) flight recording.

1. Go to 3.7 seconds in the recording.

Data Item	Fill in the Value Below from the Recordings
PRNDL Code	
Engine Speed	
Turbine Speed	
Torque Converter Slip	

- a. Graph torque slip and compare between 1.5 and 3.7 seconds. Why is the slip so much less at 3.7 seconds than at 1.5 seconds?

Torque Converter Mechanical Diagnosis

DIAGNOSIS

Instructions: Answer the following questions related to diagnosing a vehicle that has poor vehicle performance after launch.

2. What torque converter mode of operation is required after launch operation? Circle/check mark the correct answer.

<input type="checkbox"/>	Torque multiplication	<input type="checkbox"/>	Neutral
<input type="checkbox"/>	Cruise	<input type="checkbox"/>	

3. Which component is critical for this mode of operation?
-

4. What type of component failure would you expect? Circle/check mark the correct answer.

<input type="checkbox"/>	Stator stuck (no rotation)	<input type="checkbox"/>	Stator freewheels at all times
--------------------------	----------------------------	--------------------------	--------------------------------

5. If the component was failing, could it be replaced?
-



TASK THREE: POOR FUEL ECONOMY

Instructions: To diagnose a poor fuel economy concern, first identify the related components, learn how they work together, and then perform an initial diagnosis of the concern.

COMPONENTS

- Identify the components of the torque converter clutch in the table below the transmission cross-section image.

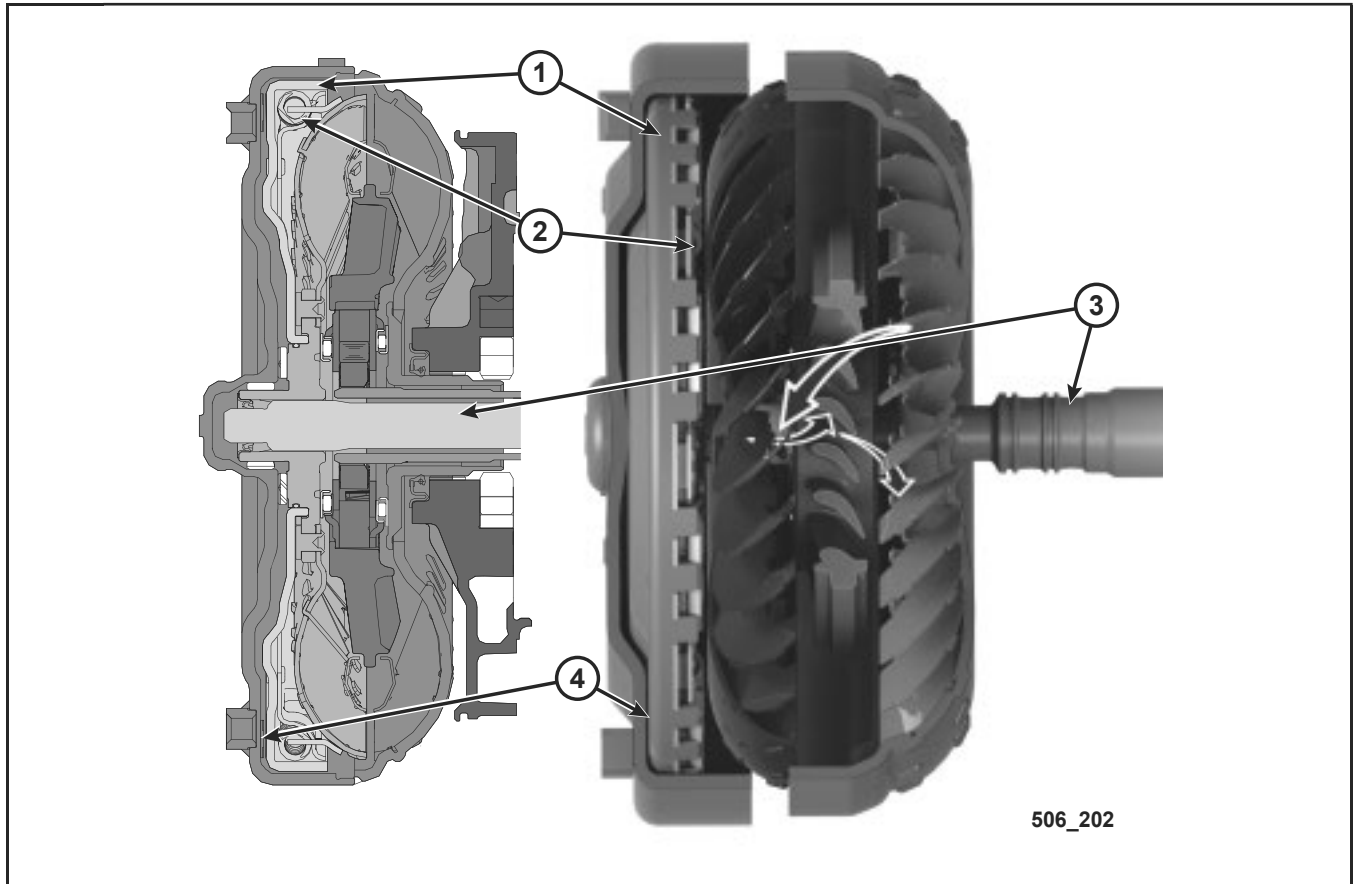

1		3	
2		4	



Torque Converter Mechanical Diagnosis

NORMAL OPERATION

Instructions: Identify internal operation of the torque converter using the [62TERecording3.xml](#) flight recording.

2. Go to 27.8 seconds in the recording.

Data Item	Fill in the Value Below from the Recordings
PRNDL Code	
Engine Speed	
Turbine Speed	
Torque Converter Slip	

3. The vehicle is at a cruising speed at this time. Why does the engine speed not match the turbine speed?
-

4. Go to 31.8 seconds in the recording.

Data Item	Fill in the Value Below from the Recordings
PRNDL Code	
Engine Speed	
Turbine Speed	
Torque Converter Slip	

- a. Why are the turbine shaft and the output shaft speeds essentially the same?
-

- b. What is the TCC status?
-



DIAGNOSIS

Instructions: Answer the following questions related to diagnosing a vehicle that has poor fuel economy.

5. How could torque converter operation affect fuel economy?

6. If the TCC was locked on at all times, what would result?

7. What other non-transmission faults could result in this symptom?



Notes: _____

ACTIVITY 3 TORQUE CONVERTER HYDRAULIC DIAGNOSIS

TASK ONE: RFE DELAYED ENGAGEMENT DURING COLD STARTS

Instructions: To diagnose a delayed engagement during cold starts, first identify the related components, learn how they work together, and then perform an initial diagnosis of the concern.

COMPONENTS

- Using TechCONNECT, identify the components involved in the flow of fluid through the torque converter using the conventional-style hydraulic diagram below. Use a 2013 D2 equipped with a 68RFE transmission.

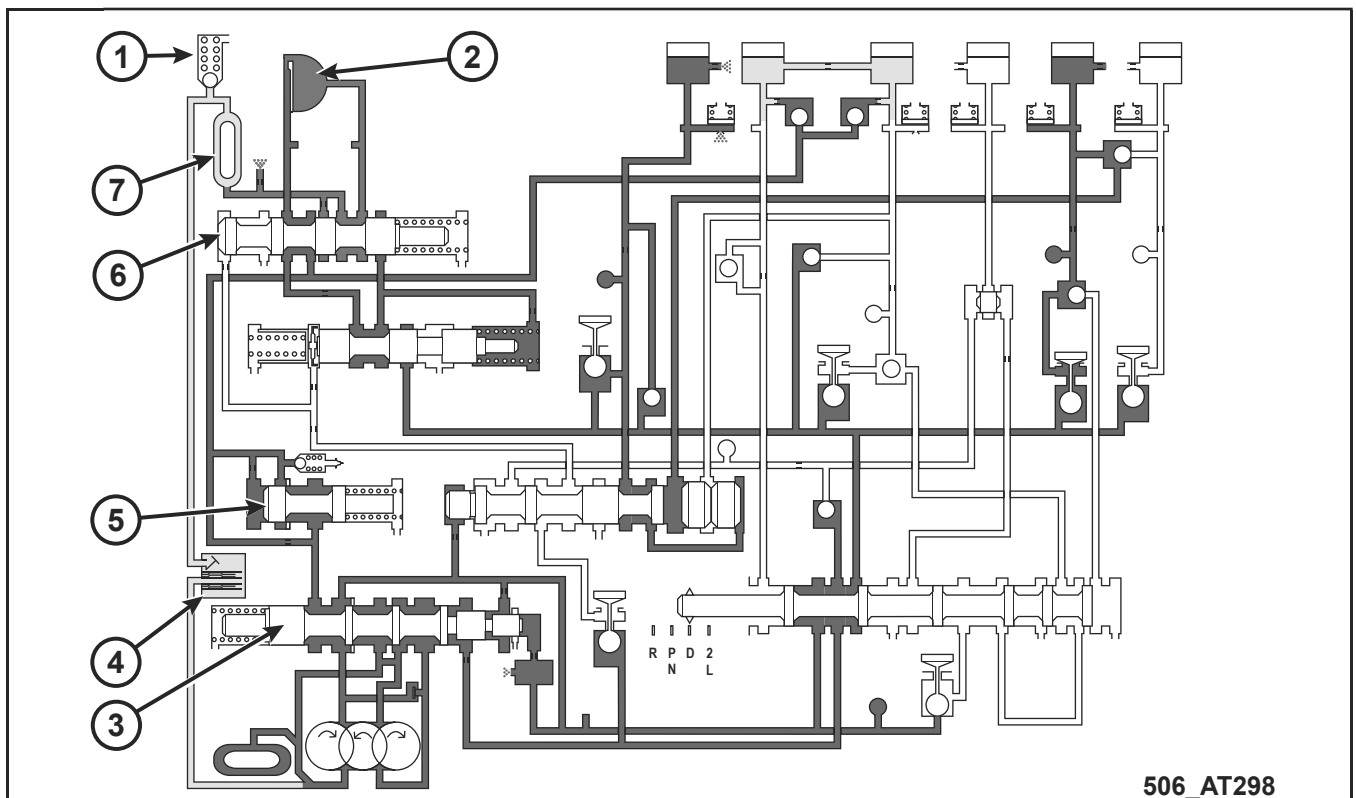

1		5	
2		6	
3		7	
4			



Torque Converter Hydraulic Diagnosis

NORMAL OPERATION

Instructions: Answer the following questions related to torque converter hydraulics.

2. Does the schematic on the previous page show a two- or three-channel system?

3. Which valve controls the fluid flow into the converter?

4. Which valve controls the pressure of the fluid flowing into the converter?

5. Where does the fluid go when exiting the converter?



DIAGNOSIS

Instructions: Answer the following questions related to diagnosing a delayed engagement during cold start. There is normal operation after first engagement, but the concern returns every morning.

6. How could a torque converter cause a delayed engagement and why?

7. What type of hydraulic fault would cause a delayed engagement?

8. Why is this only related to a cold start?



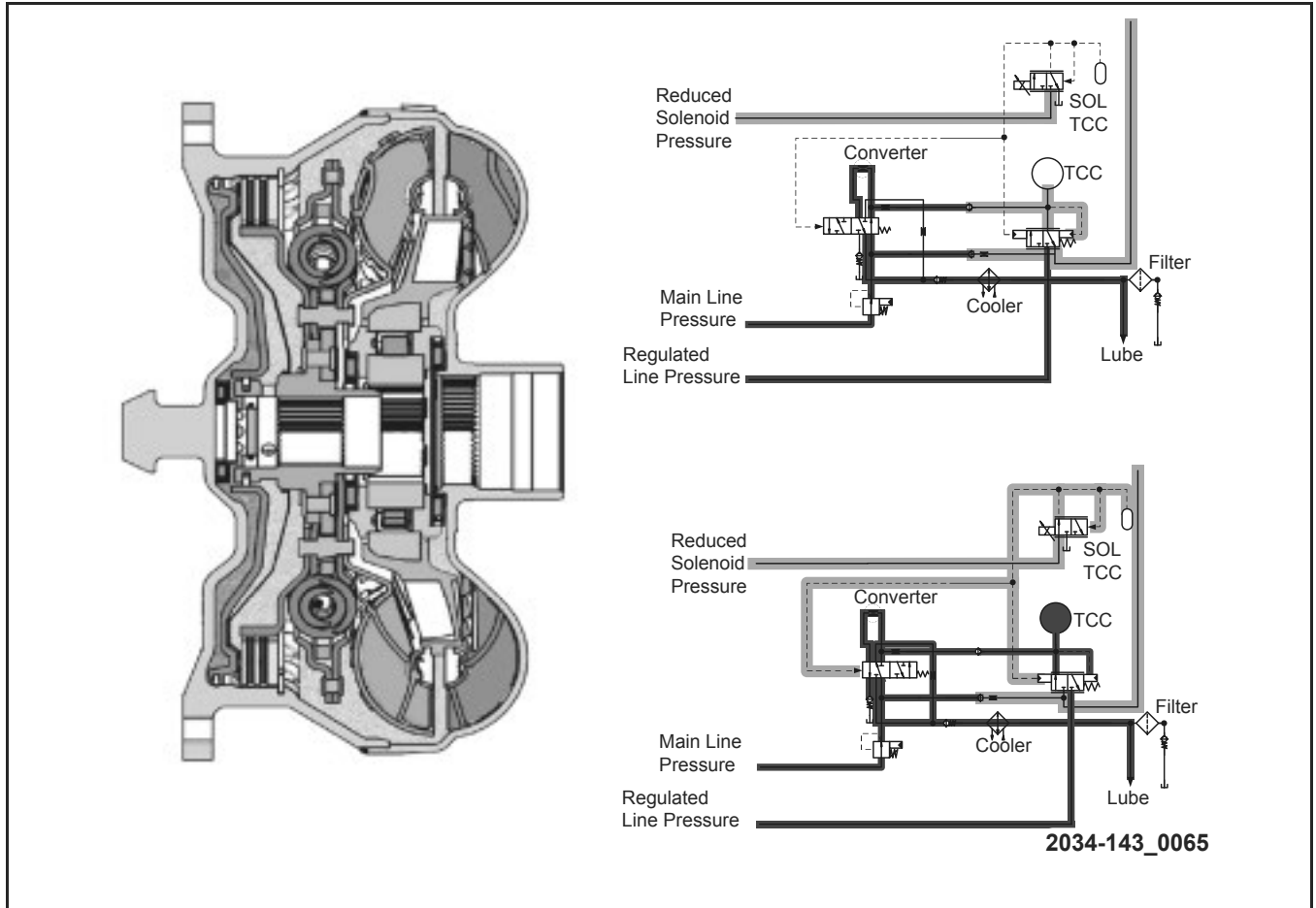

ACTIVITY 4 TORQUE CONVERTER NOISE DIAGNOSIS

Instructions: To diagnose a torque converter noise concern, first identify the related components, learn how they work together, and then perform an initial diagnosis of the concern.

1. Fill in the table with the following speed descriptions of the components in the image in the specified gear: Stopped, Engine Speed, or Slightly below Engine Speed.
 - a. Park/Neutral

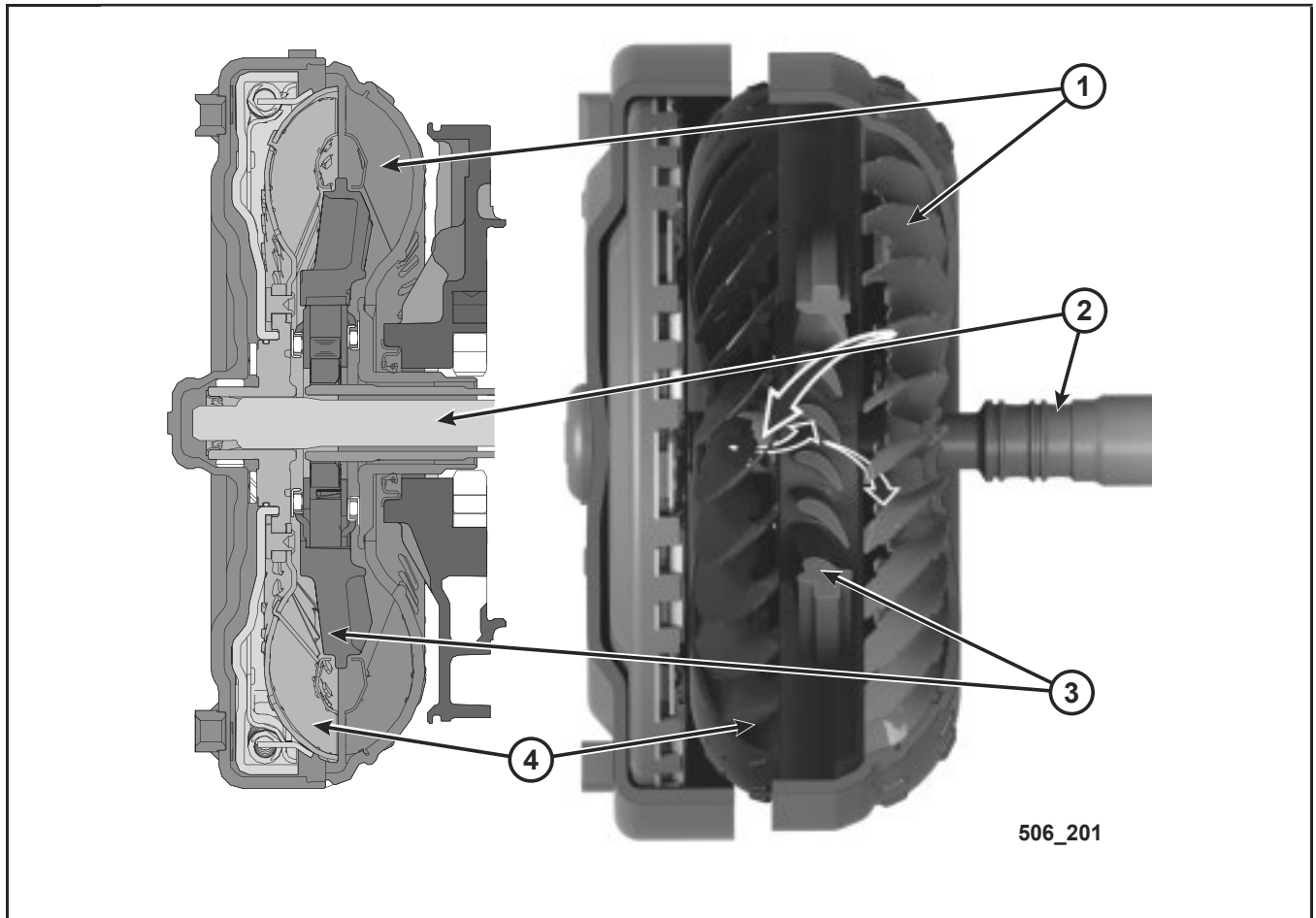

1		3	
2		4	

2. If the transmission is making noise any time the engine is running, what components of the torque converter can be responsible for the noise?

Torque Converter Noise Diagnosis

b. Drive/Reverse Launch (vehicle moving)

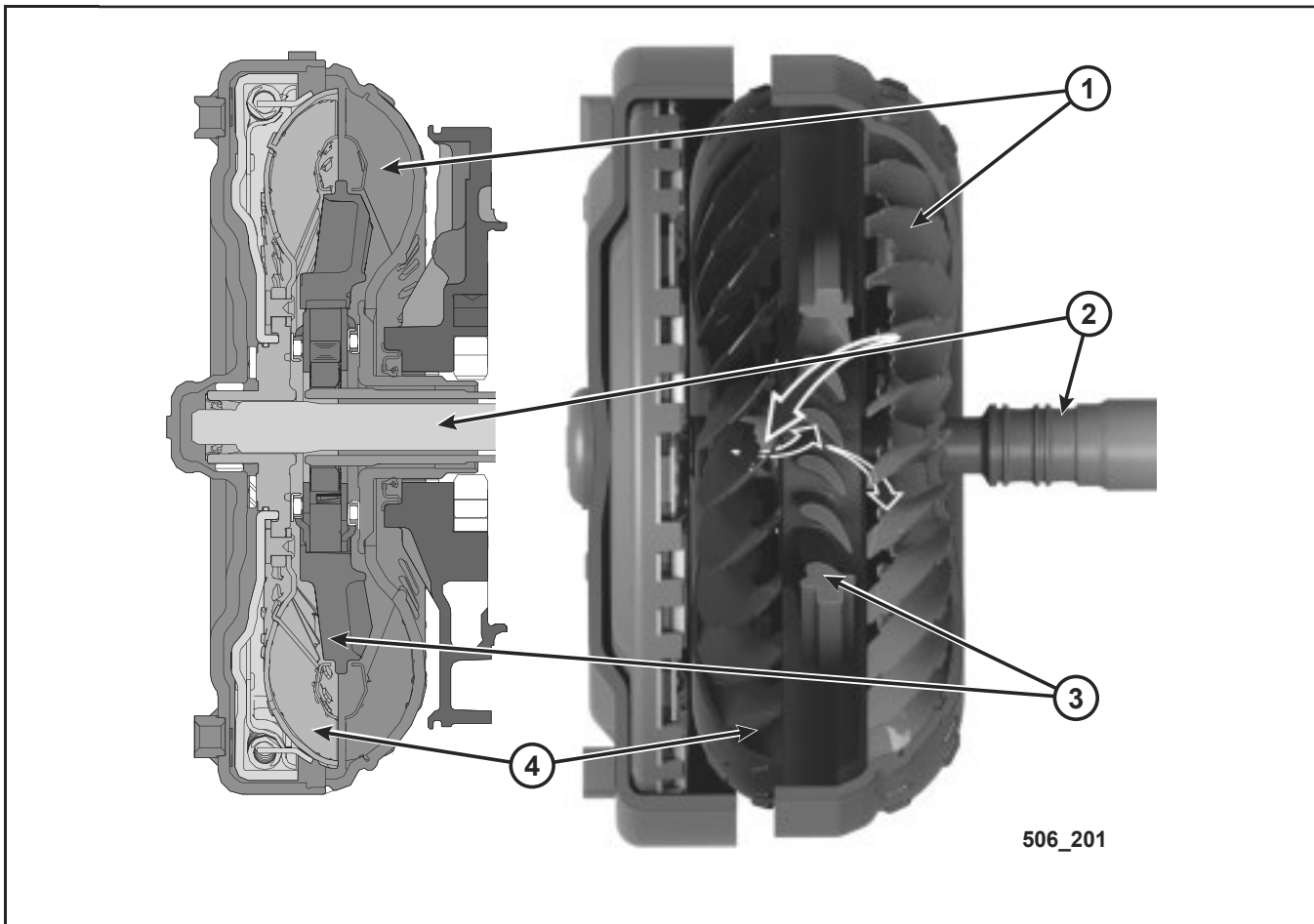

1		3	
2		4	

3. The transmission makes noise during launch in Drive and Reverse. After launch, the noise is drastically reduced and goes away completely when the TCC is applied. What component(s) could be responsible for the noise?

c. Drive Stopped

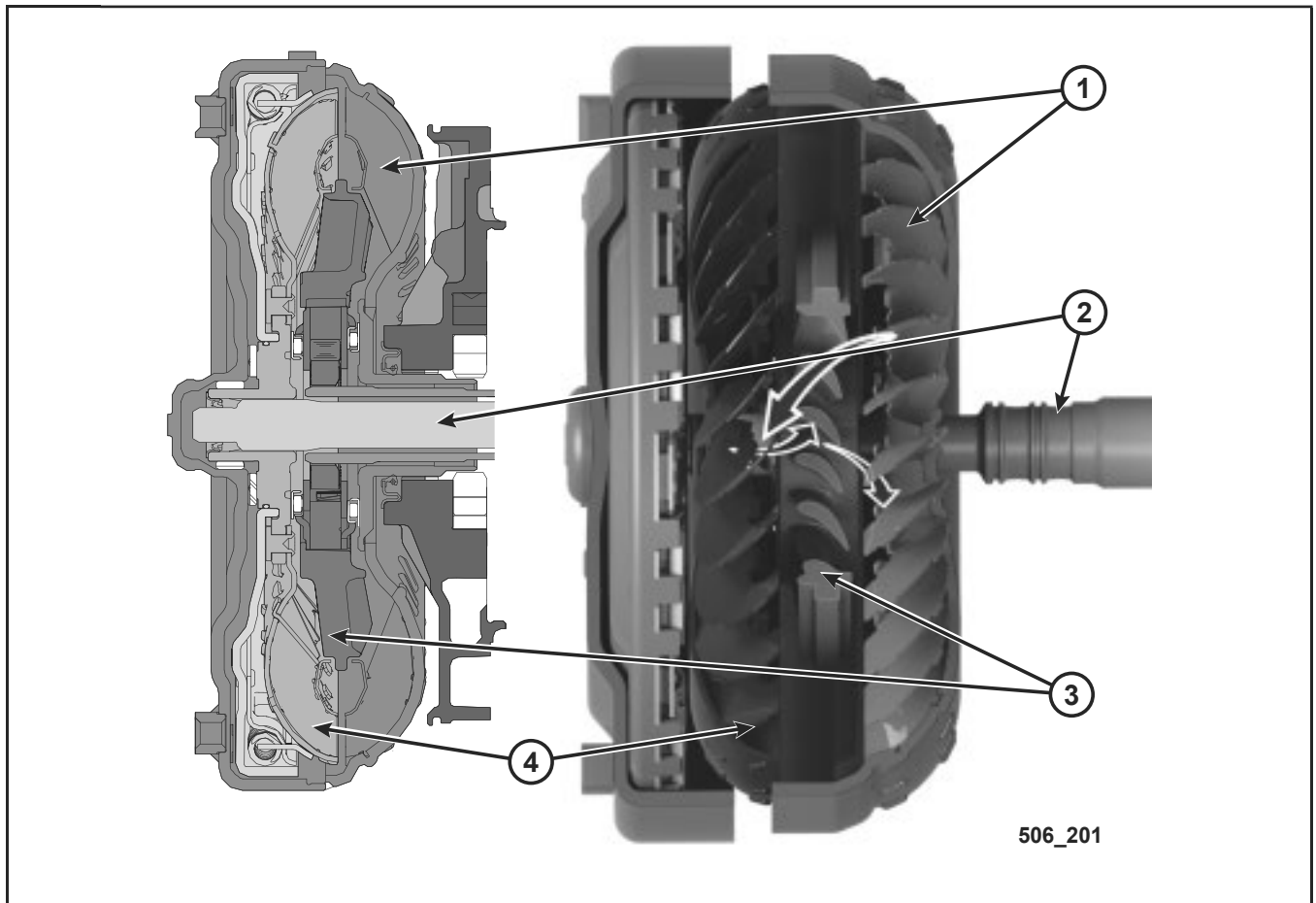

1		3	
2		4	

4. If the transmission is making the worst noise when the vehicle is stopped, what components of the torque converter can be responsible for the noise?

Torque Converter Noise Diagnosis

d. Drive Highway Speed (TCC off)

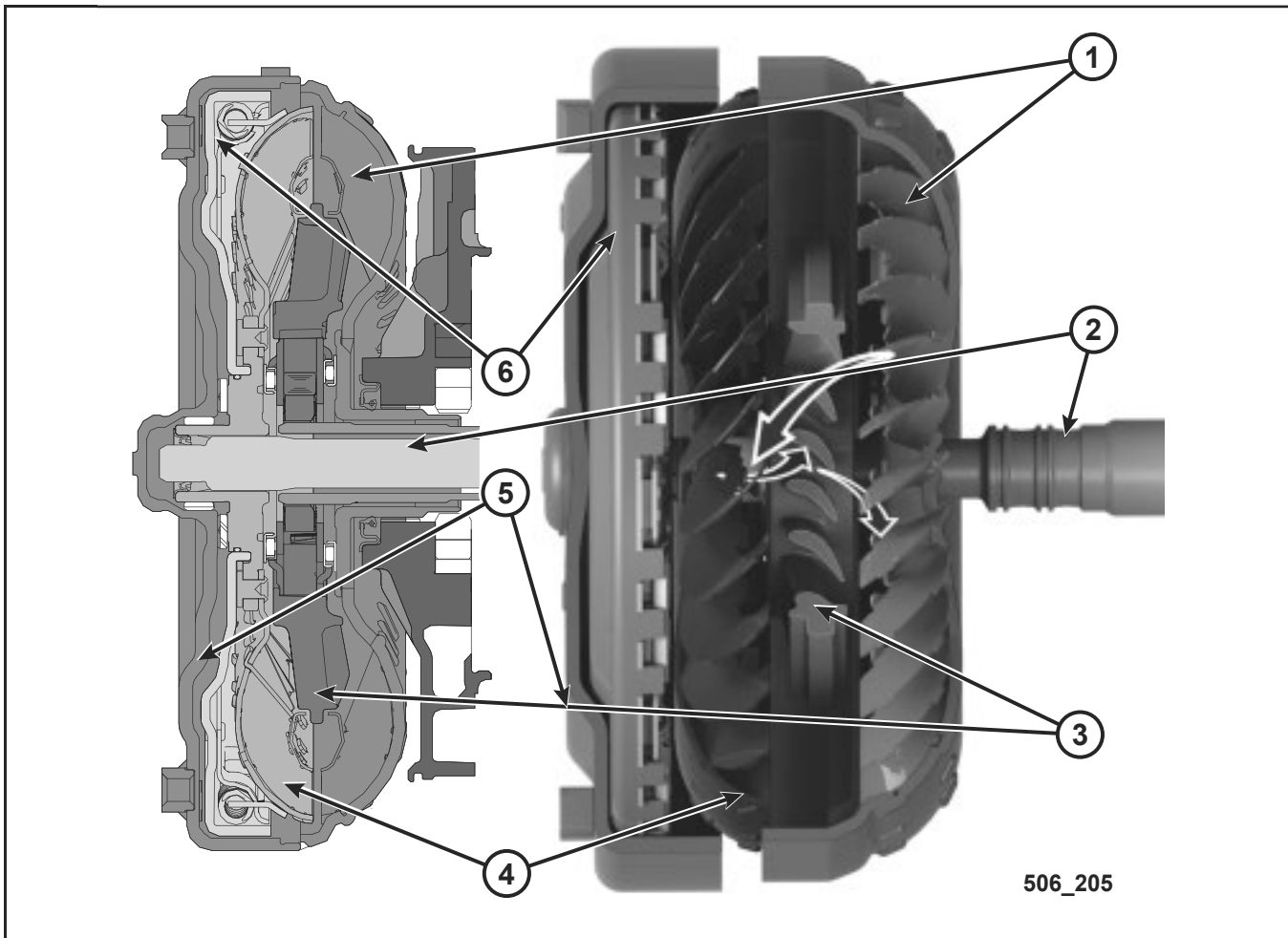

1		4	
2		5	
3		6	

5. If the transmission is making noise and vibrating during the TCC apply, what component of the torque converter can be responsible for the noise?

Notes: _____

LESSON 3 DIAGNOSTIC MEASUREMENTS AND TESTS

PURPOSE OF TESTING

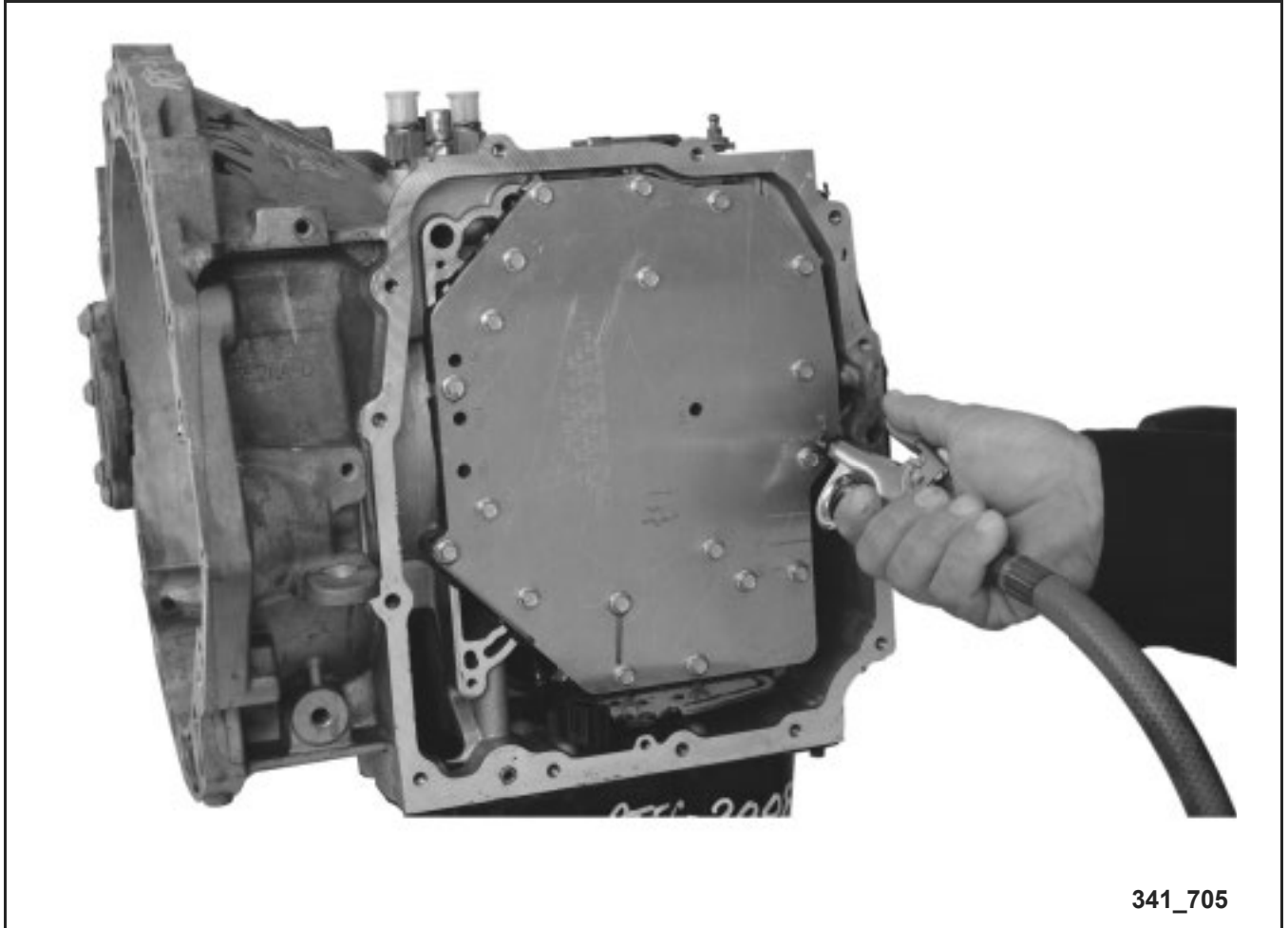

Figure 52 62TE being Air Checked on Bench with Plate

The purpose of testing is to determine the condition of a transmission so an assessment can be made to perform repairs.

TRANSMISSION LINE PRESSURE CHECK



Figure 53 Fluid Pressure Gauge and Line Adapter Attached to Transmission Test Port

Line pressure testing determines the internal condition of the transmission by measuring fluid or line pressure and the transmission's ability to adjust it.

CLUTCH AIR CHECKS

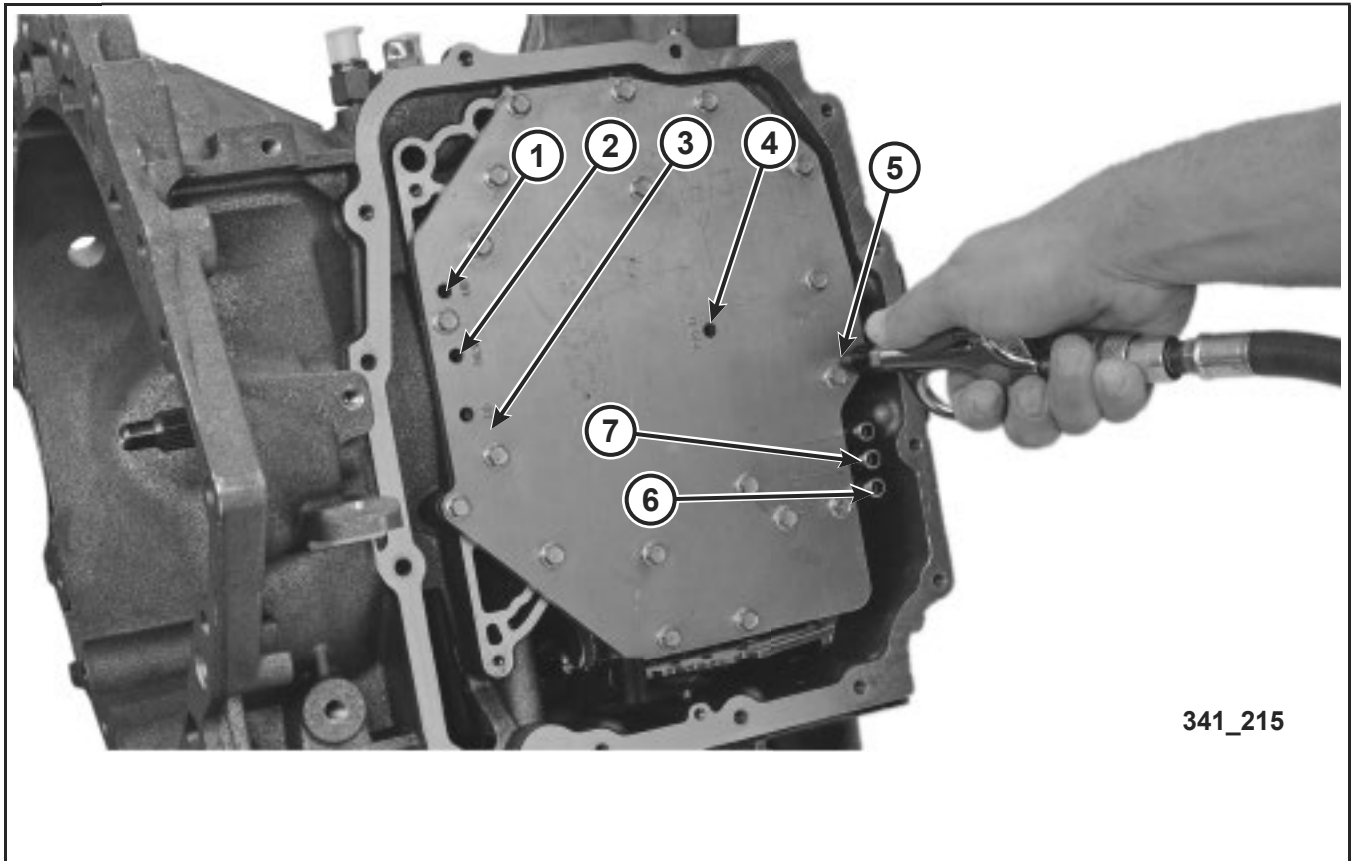

341_215

1	Underdrive Clutch Air Test Port	5	Low/Reverse Clutch Air Test Port
2	Reverse Clutch Air Test Port	6	Low Clutch Air Test Port
3	Overdrive Clutch Air Test Port	7	Direct Clutch Air Test Port
4	2/4 Clutch Air Test Port		

Figure 54 62TE Air Check Plate Ports

Clutch air testing checks the hydraulic and mechanical performance of a clutch while it is in the vehicle for diagnostics, or during disassembly.

ENDPLAY MEASUREMENTS

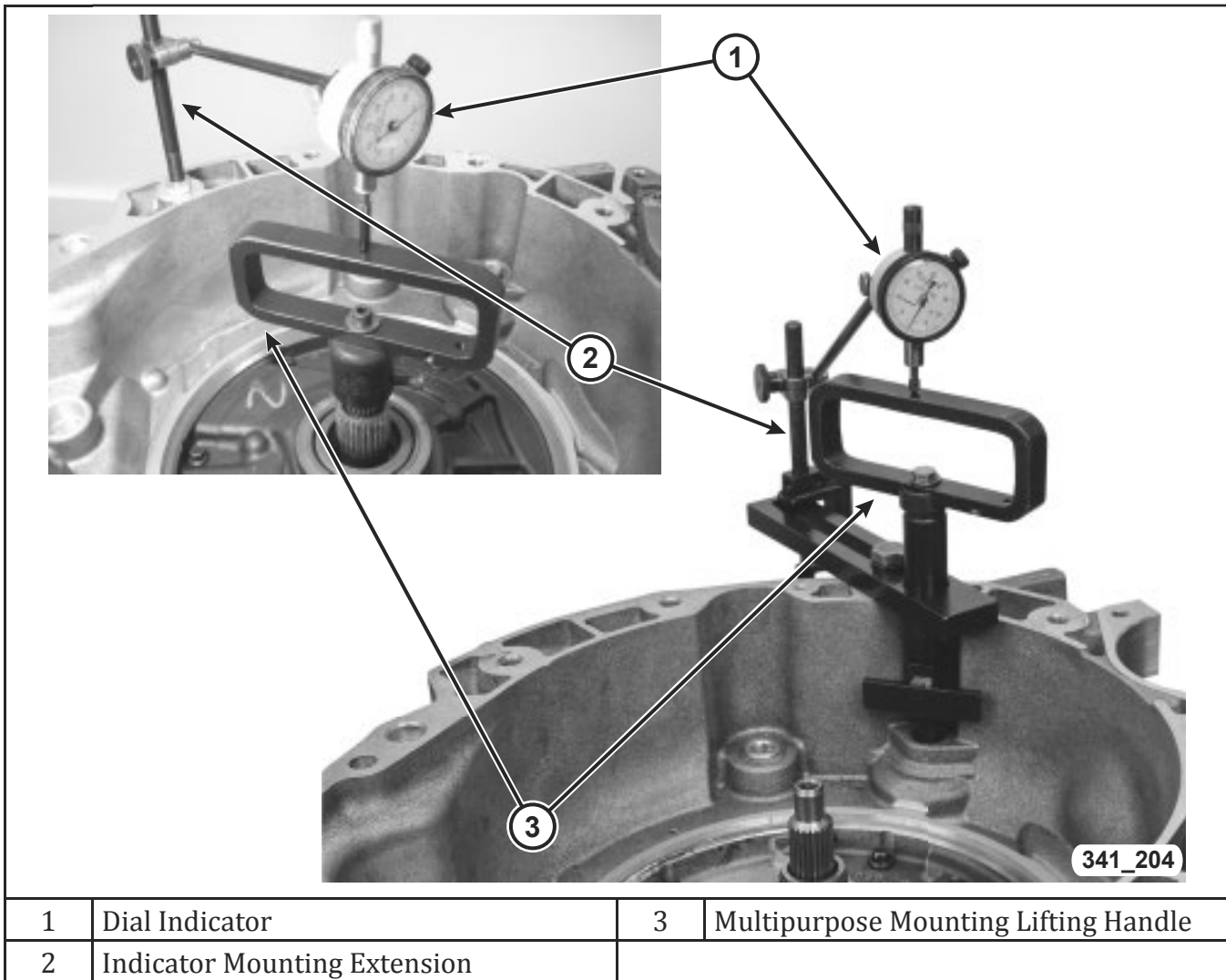

Figure 55 Endplay Measurement Tools

Endplay measurements check the transmission condition before disassembly just as the other measurements do. It also checks the assembly work to be correct after assembly.

Too much endplay or too little endplay can be corrected with shims called selectives.

DEMONSTRATION 3 LINE PRESSURE CHECK

Instructions: This demonstration will cover the line pressure check procedures. This page is primarily for notes and has a few key questions on the topic.

1. Where can you locate the normal line pressure readings?

2. Which transmission is being tested in the classroom?

3. Using service information, what is the normal pressure in Drive for this vehicle?

4. Is a higher rpm than idle required for this testing?

5. What does a normal pressure reading indicate?

6. Why are pressures different in different gears?

7. If the measurement is below the specification, what does that indicate about the transmission?



ACTIVITY 5 ENDPLAY CHECK

Instructions: Perform the endplay measurements using service information, and answer the questions below.

1. Position the transaxle so the input shaft is vertical. Set up the End Play Socket Set, 8266B, (1) and dial indicator (2) as shown.

NOTE: Use a base clamp adapter and attach the dial indicator to the transmission case. Set the indicator dial on the handle for consistent endplay readings.

2. Measure input shaft endplay and record below. This will be used for reference during assembly.

3. What is the purpose of measuring endplay?

4. What does too much endplay indicate?

5. What does too little endplay indicate?

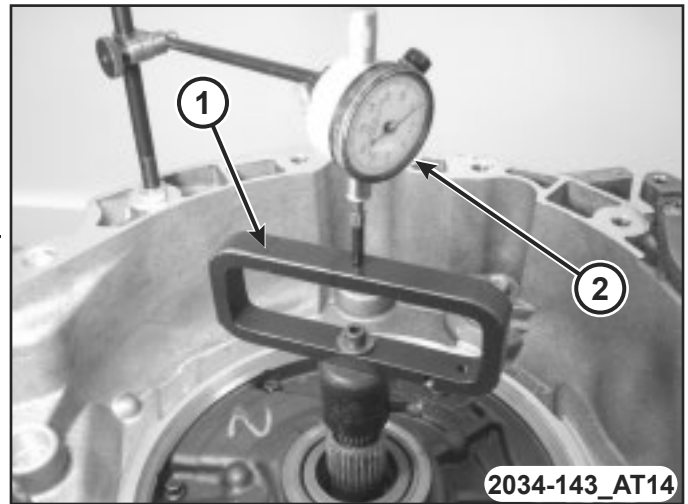

ACTIVITY 6 VALVE BODY REMOVAL AND AIR CHECK

Instructions: Perform the clutch air checks using service information, noting and following any cautions and warnings, and answer the questions below.

1. Position the transaxle so the side pan is vertical.

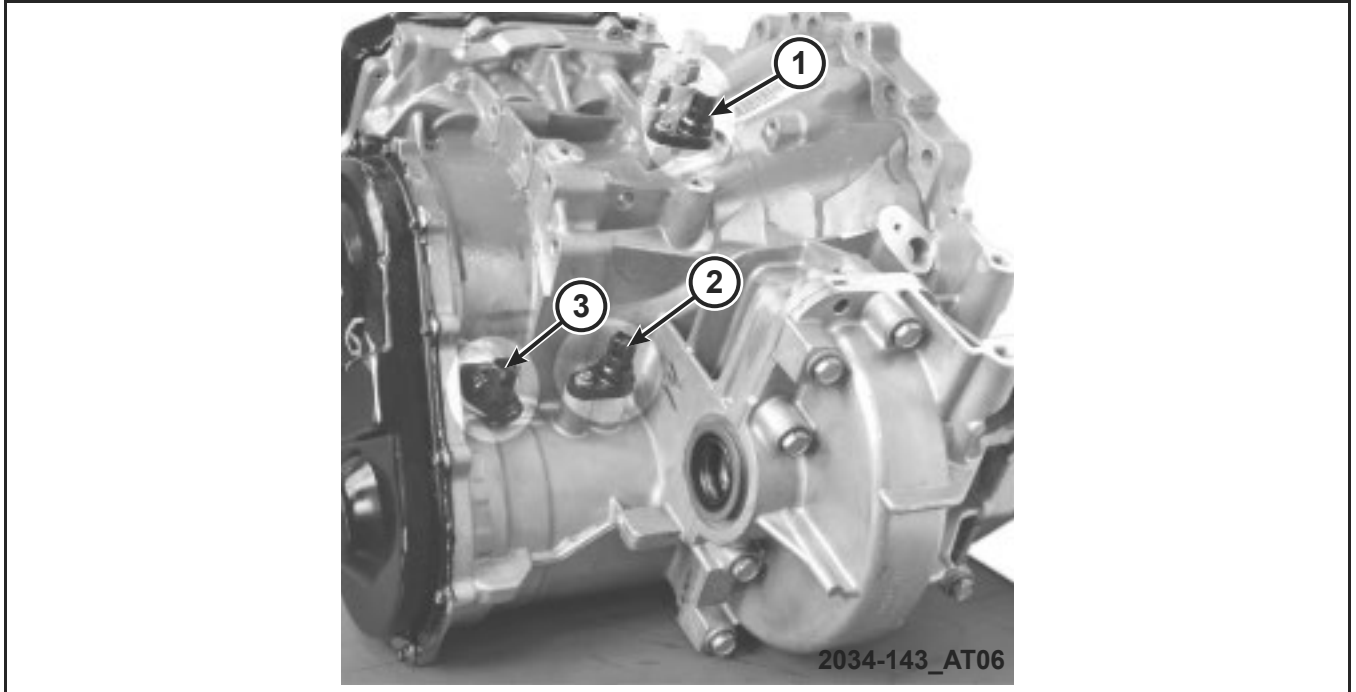

2. Remove the three speed sensors (1, 2, and 3).
 - a. Are the speed sensors interchangeable?

Valve Body Removal and Air Check

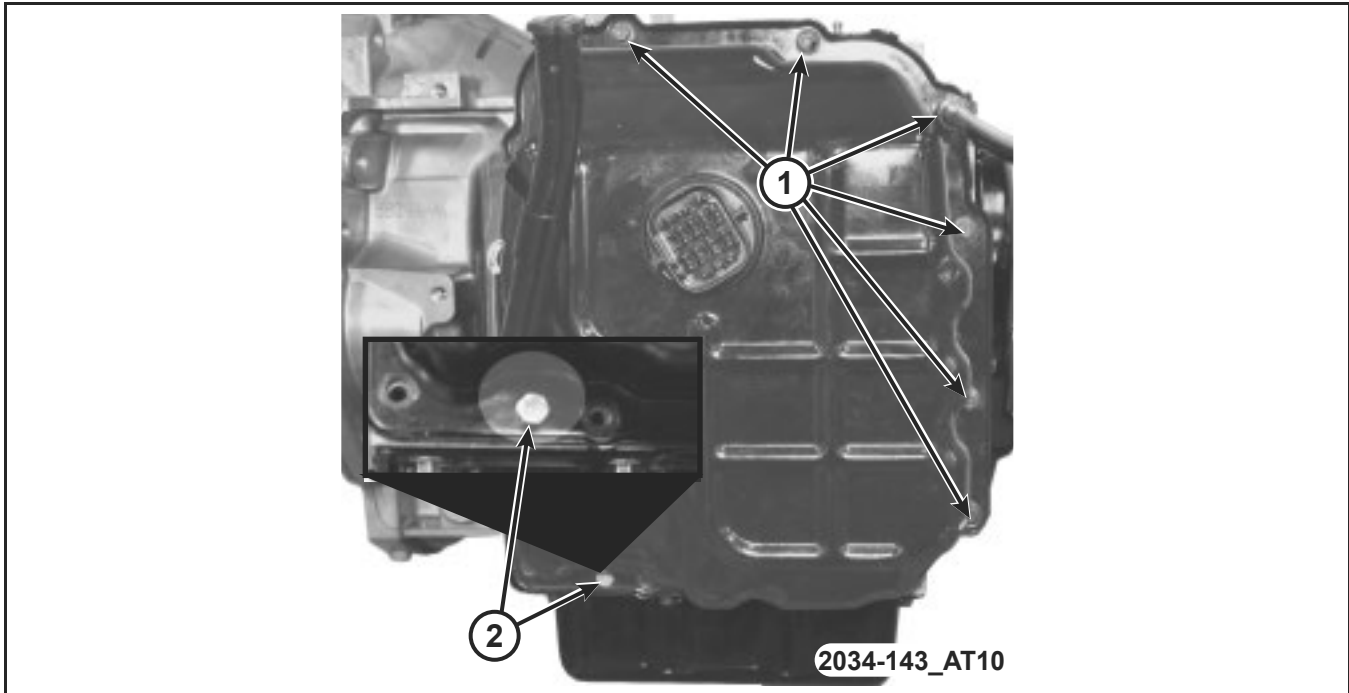

3. Remove all the bolts (1) from the valve body pan rail area.
4. Remove the main line pressure tap plug (2).
5. Remove the valve body cover pan.

NOTE: Later production transmissions use a set screw type plug (2) that does not need to be removed to remove the valve body cover.

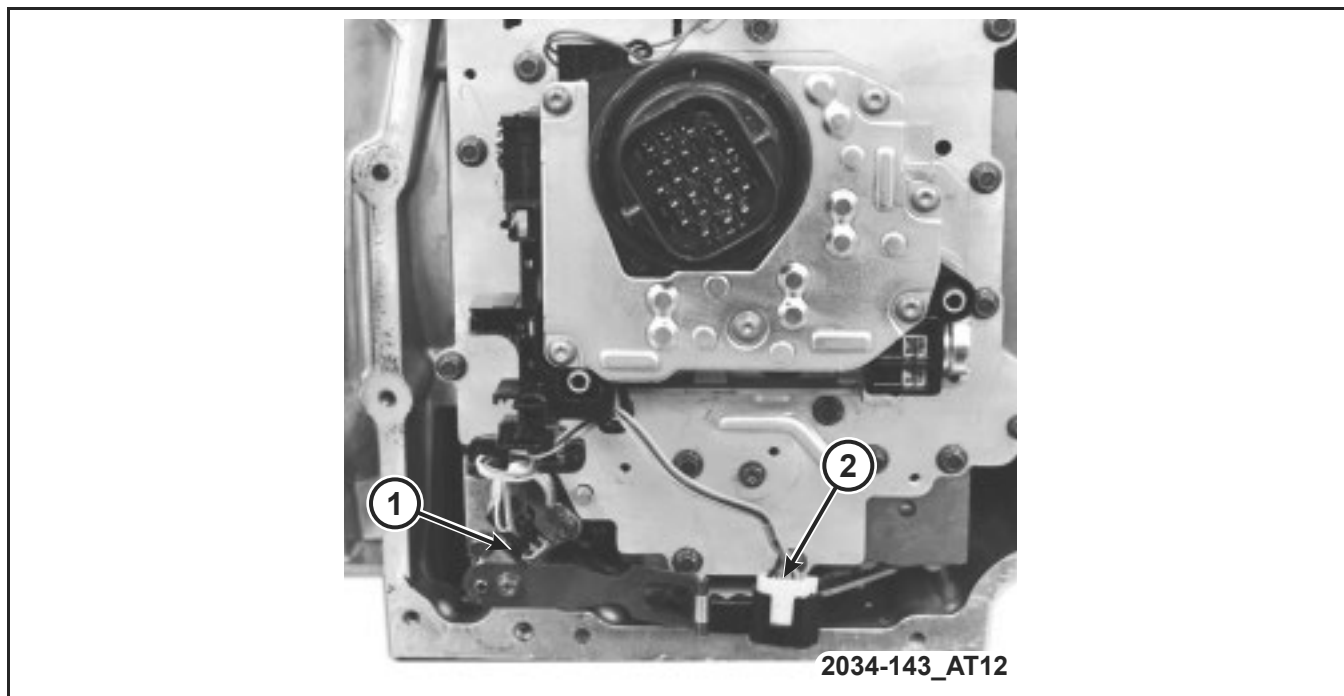

6. Remove the hold down bolt (1) from the rooster comb detent spring.

CAUTION: Be careful not to break off the transmission range sensor's electrical retaining tab.

7. Disconnect the electrical connector (2) from the transmission range sensor.
8. Swing the range sensor and comb to the left, out of the way.

Valve Body Removal and Air Check



NOTE: Check for loose valve body bolts while removing a valve body. Loose valve body bolts can be the root cause of a shift concern.

9. Remove the valve body bolts.

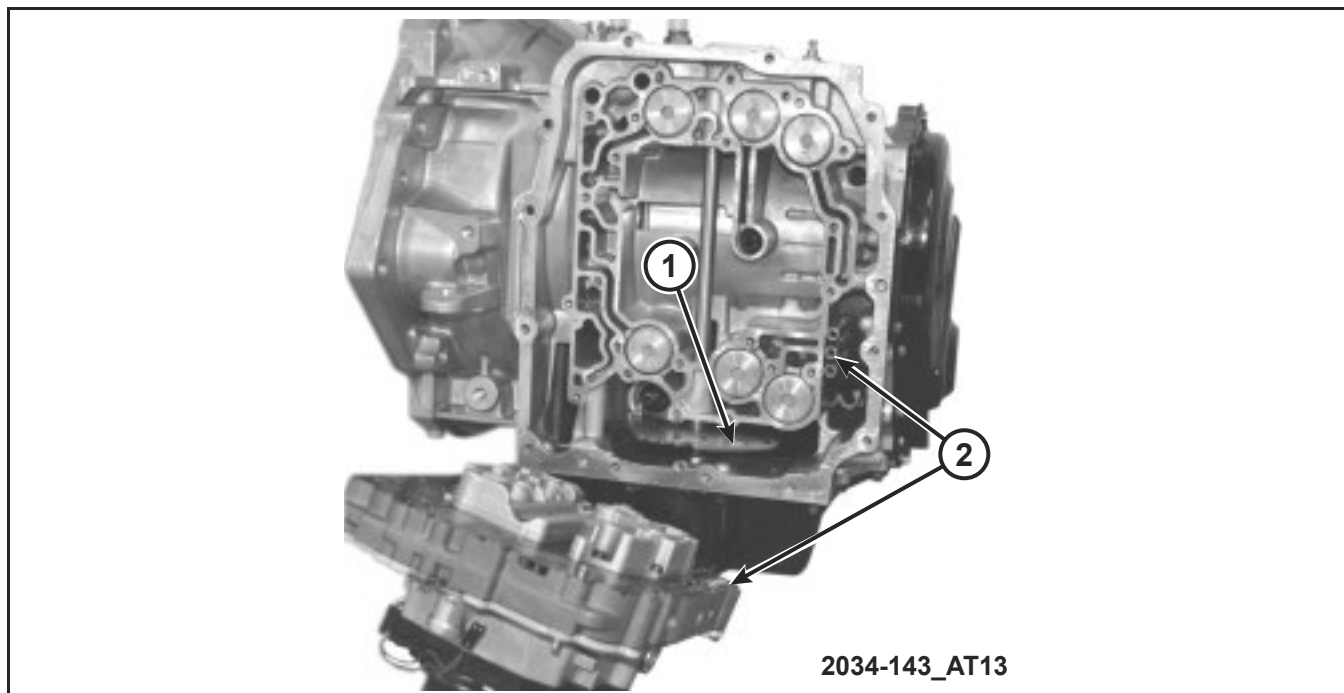

10. Pull up on the valve body at the transfer tube area (2) while guiding the manual valve out of the rooster comb (1).

NOTE: You may need to turn the rooster comb to provide enough room to remove the valve body.

CAUTION: The valve body is easily damaged. Handle the valve body with care.

11. Remove the valve body assembly and place it on a clean surface.

Valve Body Removal and Air Check

12. Install the Air Test Plate, 9741, as shown in the graphic below.

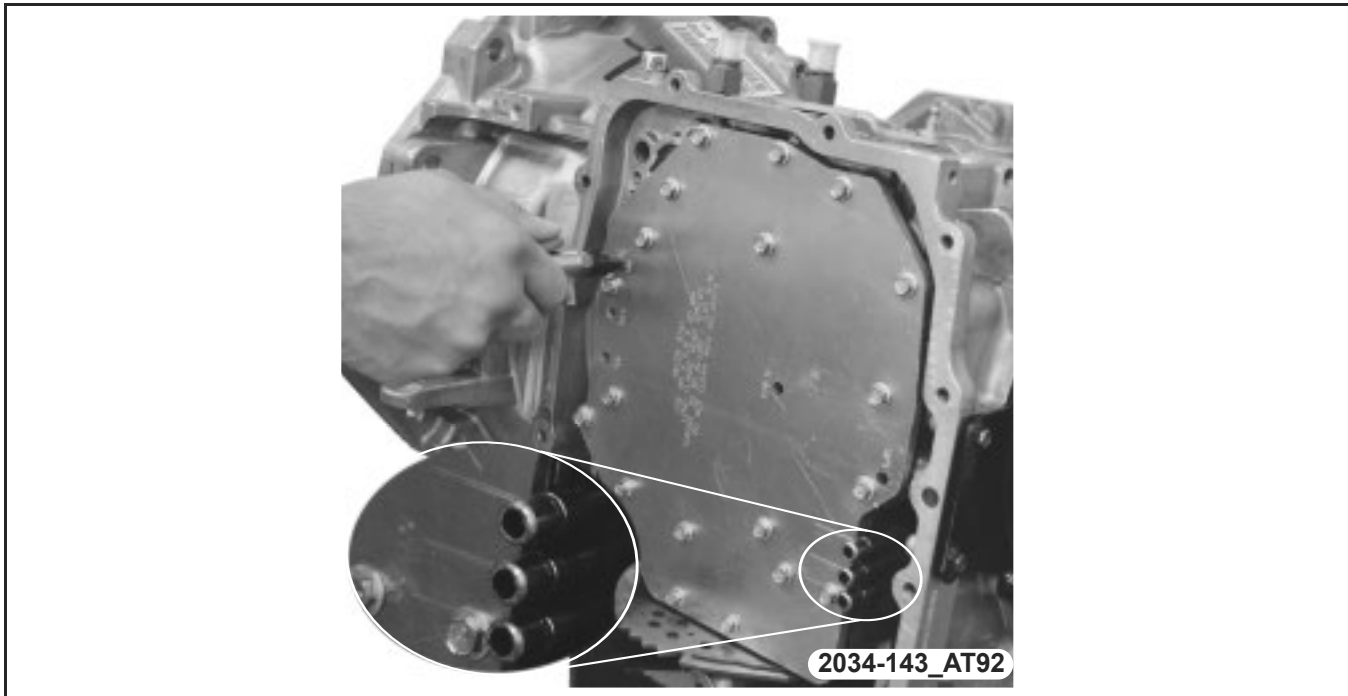

13. Using 30 psi of air pressure, air test the clutches and record the results below.

UD		OD	
R		2/4	
L/R		LC	
DC			

14. What should be expected for a normal response to the test?
-
15. Is some amount of leakage normal? Why?
-
16. If there is no leaking sound and the normal thud sound is missing, what does that mean?
-
17. What types of malfunctions are indicated by a major air leak?
-
18. Are any of the clutches difficult to apply with air?
-
19. A vehicle comes into the dealer with a DTC for incorrect gear ratio. The concern is verified, the valve body is removed, and the transmission is air checked. The fluid is clean and the clutches passed air check. What is the most likely cause for this concern?
-
20. Remove the air test plate.



LESSON 4 FLUID PUMP

FLUID PUMP MECHANICAL OPERATION



1	Crescent Gear Pump	3	Two-stage Gear Pump
2	Gerotor Gear Pump	4	Vane Pump

Figure 56 Types of Oil Pumps

General Operation

The oil pump in an automatic transmission causes the fluid to flow and circulate through the hydraulic system. The oil pump drive gear connects with the torque converter cover and rotates at engine speed. The drive gear is either keyed or splined at the hub of the torque converter or driven by a shaft that is internally splined to the front part of the converter cover, nearest the engine.

Crescent Gear Pumps

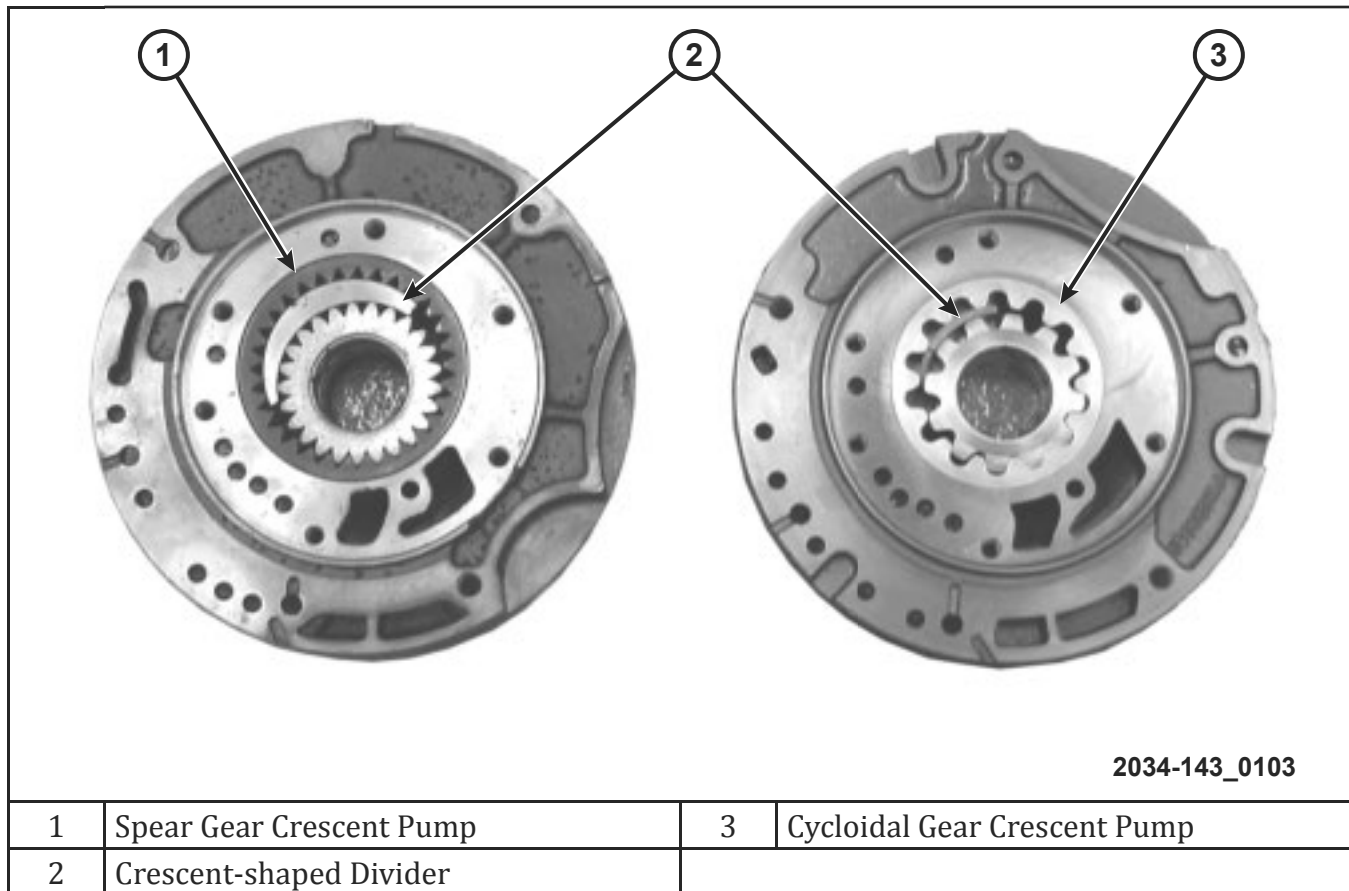

Figure 57 Typical Crescent Pumps

The crescent pump, also called the internal gear pump, consists of an inner gear that meshes with an outer gear inside the pump housing. The engine drives the torque converter, and the impeller hub drives the inner pump gear, which drives the outer pump gear.

The crescent pump uses a crescent-shaped divider between the gears. The oil is trapped between the divider and the gear teeth as it is carried to the outlet. The crescent-shaped divider extends into the pumping chamber and seals off the inlet and outlet ports. The compact design of the crescent pump saves space and reduces the complexity of the system.

In recent years, certain transmissions began using a crescent pump with a dual cycloidal gear design. The gears of the dual cycloidal pump have fewer teeth that are larger and more rounded when compared with the previous design crescent pump. The dual cycloidal pump design provides improved pump performance, vehicle fuel economy, and pump noise reduction.

Gerotor Pumps

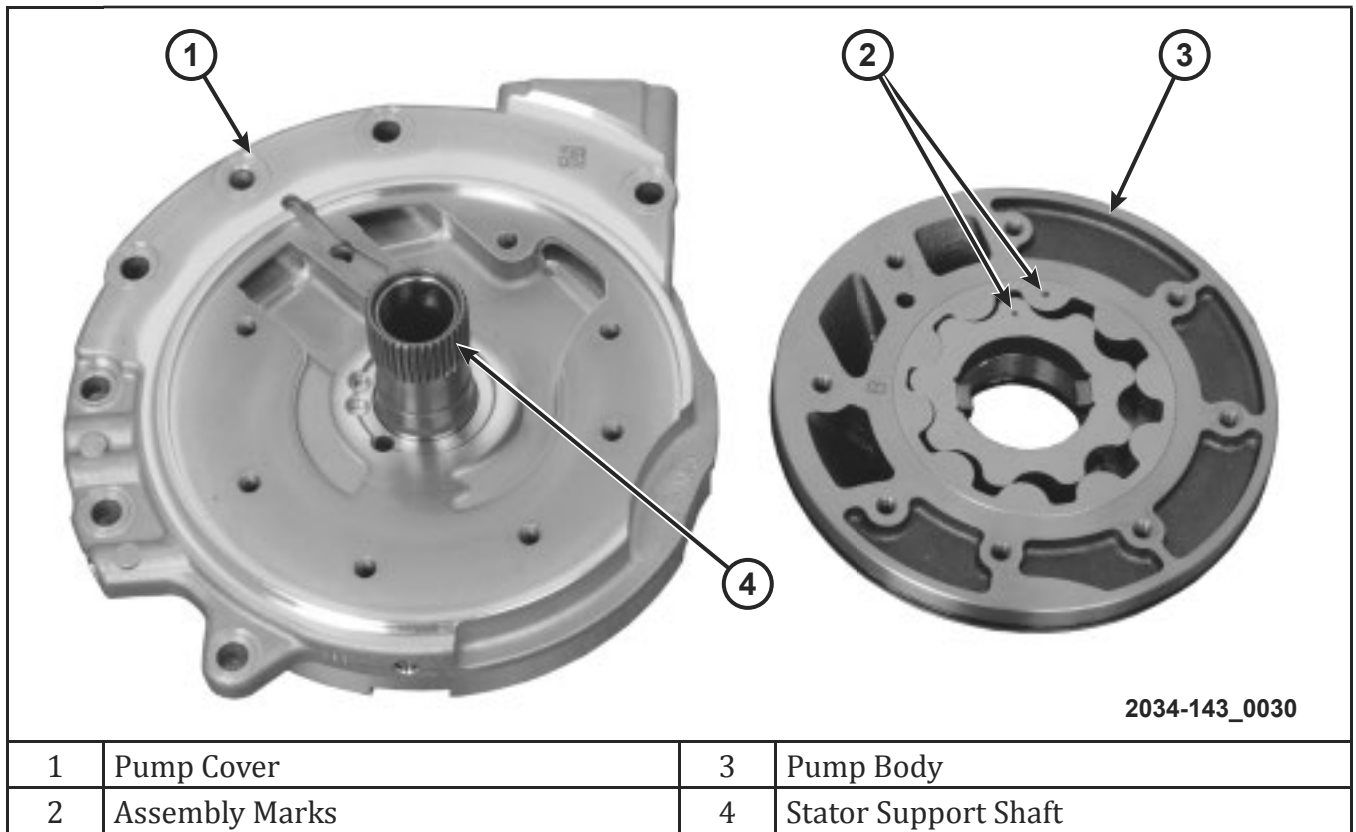

Figure 58 Gerotor Pump

The generated rotor pump, known as the gerotor pump, also uses an inner and outer gear design. The inner gear has one less tooth than the outer gear. As the inner gear drives the outer gear, the space between the gears increases as the gear teeth separate and pass the inlet port, and then decreases as the gear teeth come together and pass the outlet port.

Note that some applications require orientation of the gears in the pump body. In the application shown, the gears must be installed with the dots facing up. This ensures that the chamfers on the opposing face mate with the pump pocket surface.

Dual Stage Pumps

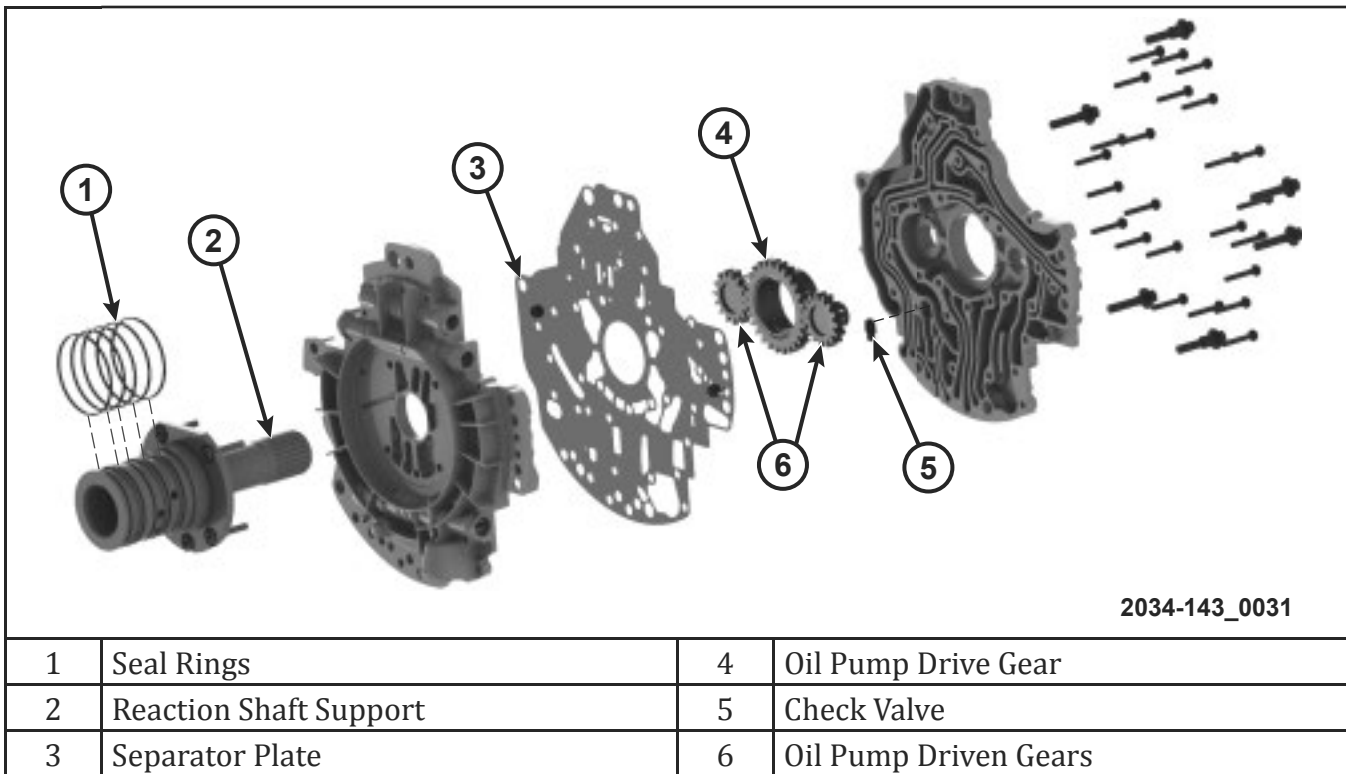

Figure 59 Dual Stage Multi-gear Oil Pump Assembly (RFE shown)

The dual stage oil pump consists of two driven gears (primary and secondary), which are driven by the torque converter impeller hub through a central drive gear. The gears are located inside the pump housing, which is part of an assembly that includes a pump valve body and reaction shaft support.

When the driven gears rotate, the rotating gear teeth create a low-pressure area between the teeth, and atmospheric pressure in the sump forces the fluid through the filter to fill the low pressure area. As the gears rotate and come back into mesh, pressurized fluid is forced into the pump outlet and to the valves in the oil pump.

At low speeds, both driven gears supply fluid to the transmission. As speed increases, flow from the primary driven gear becomes sufficient to meet the transmission fluid system demand, and flow from the secondary driven gear is recirculated through the main pressure regulator valve. When secondary flow is recirculated, the check valve located between the pump outlet closes, and the primary driven gear supplies all the fluid to the transmission.

Pump Body Valves

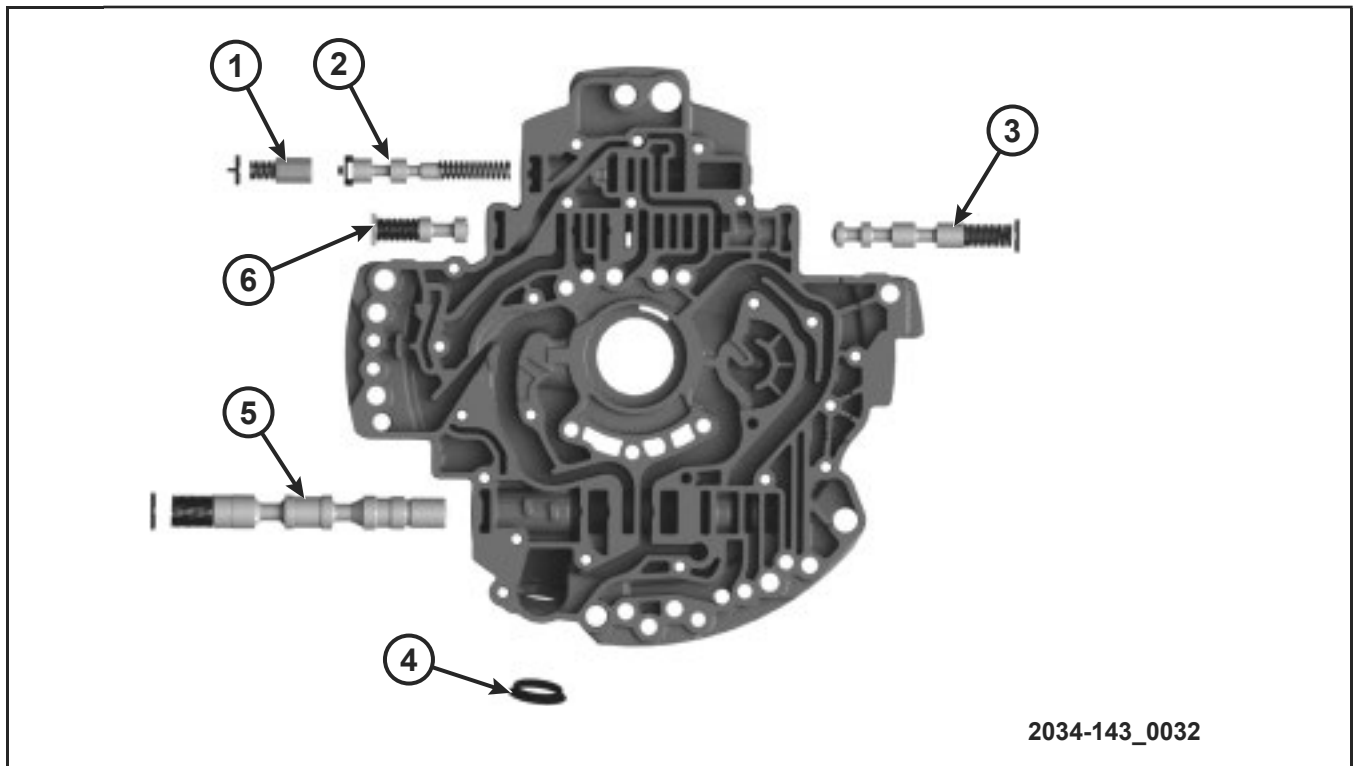

1	TCC Accumulator	4	Primary Oil Filter Seal
2	Converter Clutch Regulator Valve	5	Pressure Regulator Valve
3	Converter Clutch Switch Valve	6	Torque Converter Limit Valve

Figure 60 Fluid Pump Valve Body Components (RFE shown)

Some transmission oil pumps contain valves in the oil pump body. These valves may be used to control or limit hydraulic pressure in the transmission and torque converter. The main pressure regulator valve controls line pressure. In case of a limp-in condition, the pressure regulator valve sets line pressure to its maximum value. The torque converter limit valve is used to regulate fluid pressure to the torque converter.

When servicing the RFE transmission, do NOT short-cut and skip the step about replacing the filter seal.

Fluid Pump

Chain Drive Oil Pump

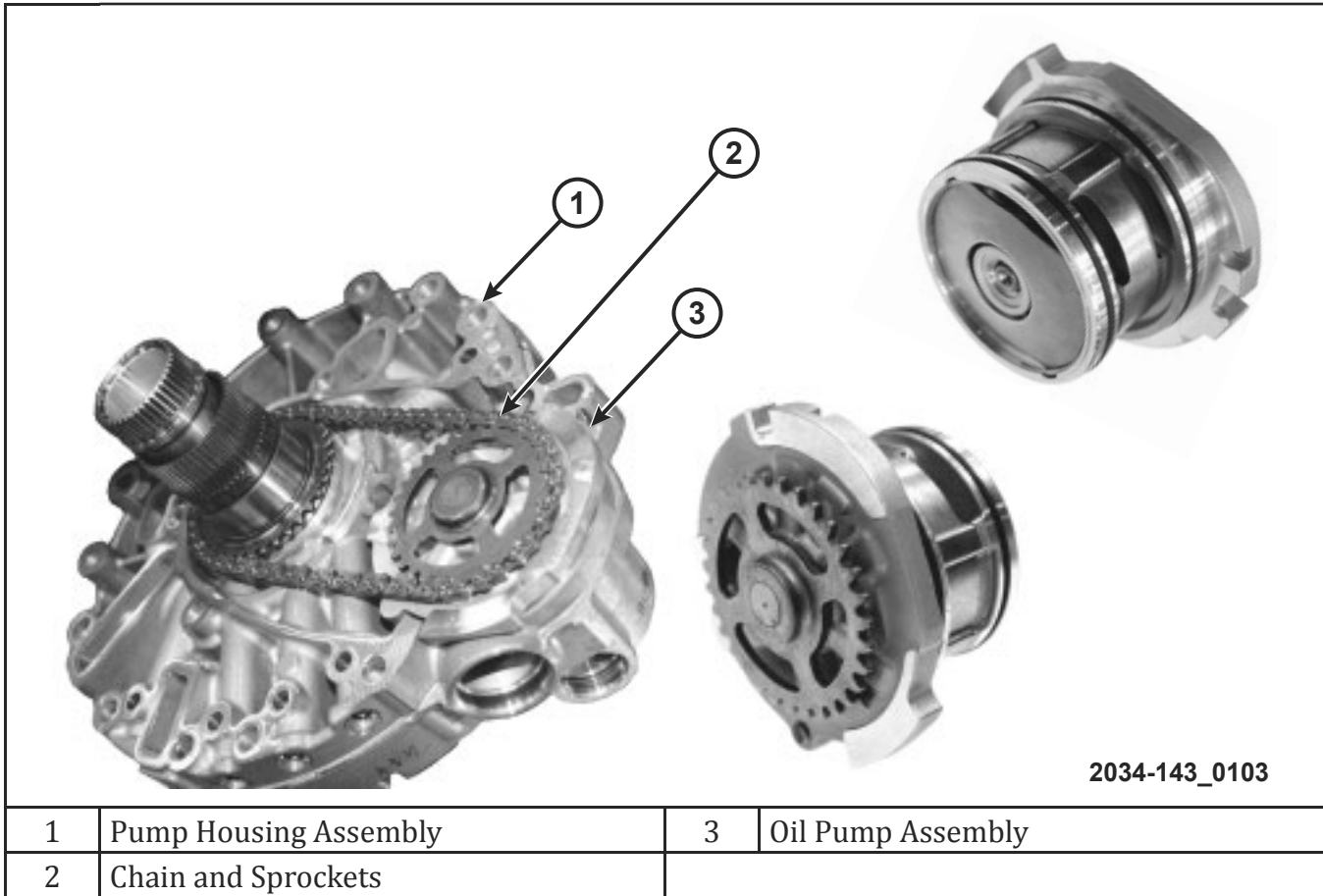

Figure 61 Chain Drive Pump Housing Assembly (8HP45/845RE shown)

Some oil pumps are off-set from the transmission center line to allow greater flexibility of design, packaging, and pump style. This style oil pump is located just behind the torque converter, between the pump housing and cover assemblies. The torque converter drives the fluid pump assembly using a chain and sprockets.

Vane Style Oil Pump

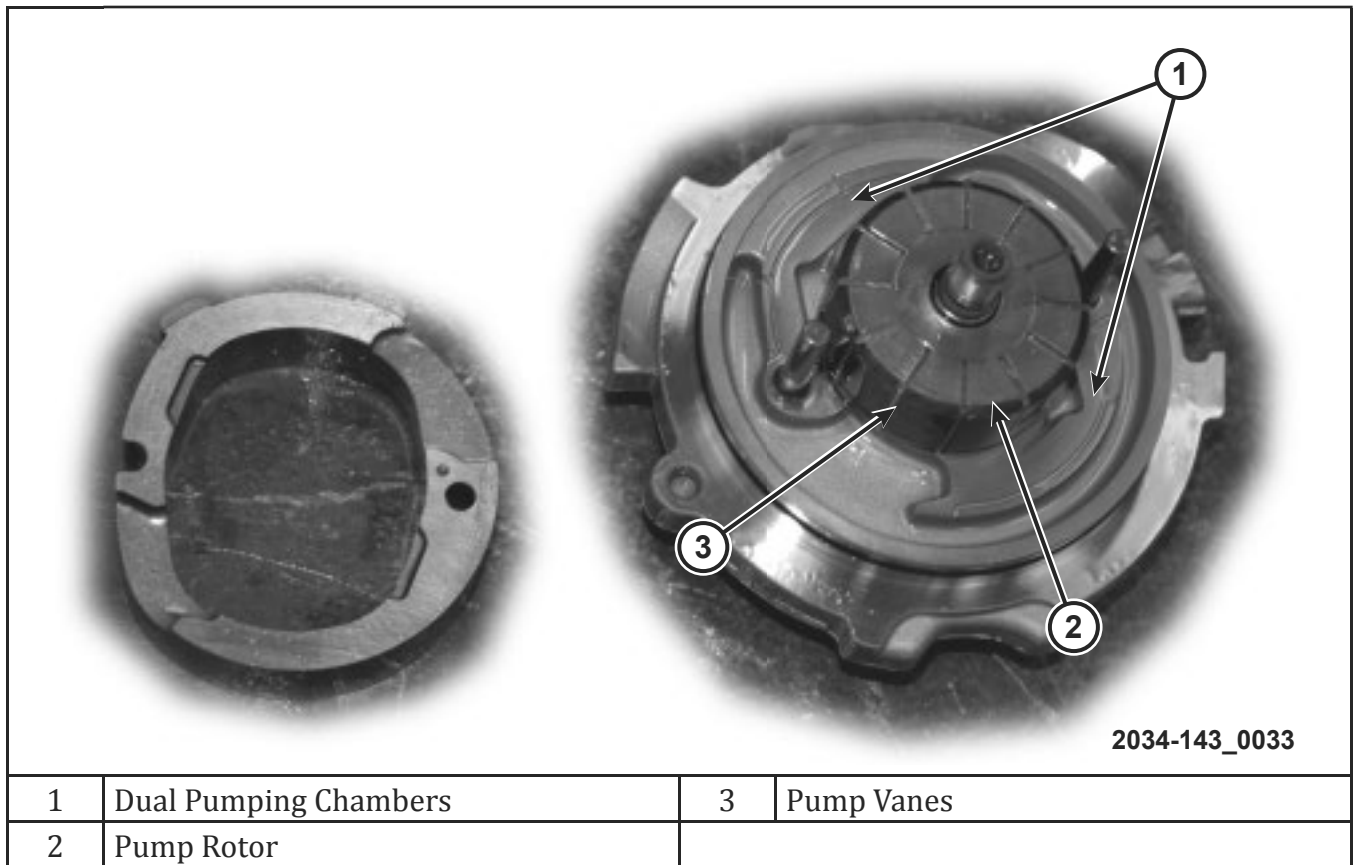

Figure 62 Vane Style Oil Pump (CVT shown)

Vane oil pumps use a series of vanes that slide within channels. As the inner rotor turns, centrifugal force pushes each vane toward the outer wall of the pump cavity. The space between each vane progresses through a cycle:

- Small-to-large to draw fluid from the sump
- Large-to-small to pressurize the fluid in the main line

The oil pump shown here is a double-stroke vane pump. The pump has two inlet ports, two pumping chambers, and two outlet ports, allowing it to produce the fluid volume necessary for all operating conditions.

Fluid Pump

FLUID PUMP HYDRAULIC OPERATION

Closed-Loop Line Pressure Control

Fluid pressure, or line pressure as it is called in an automatic transmission, is what supplies the energy to actuate clutches, lubricate components, and allow cooling of the transmission. The fluid pump is driven by the engine using the converter hub. Pressure control is required so pressure does not exceed a specified level that may damage the transmission.

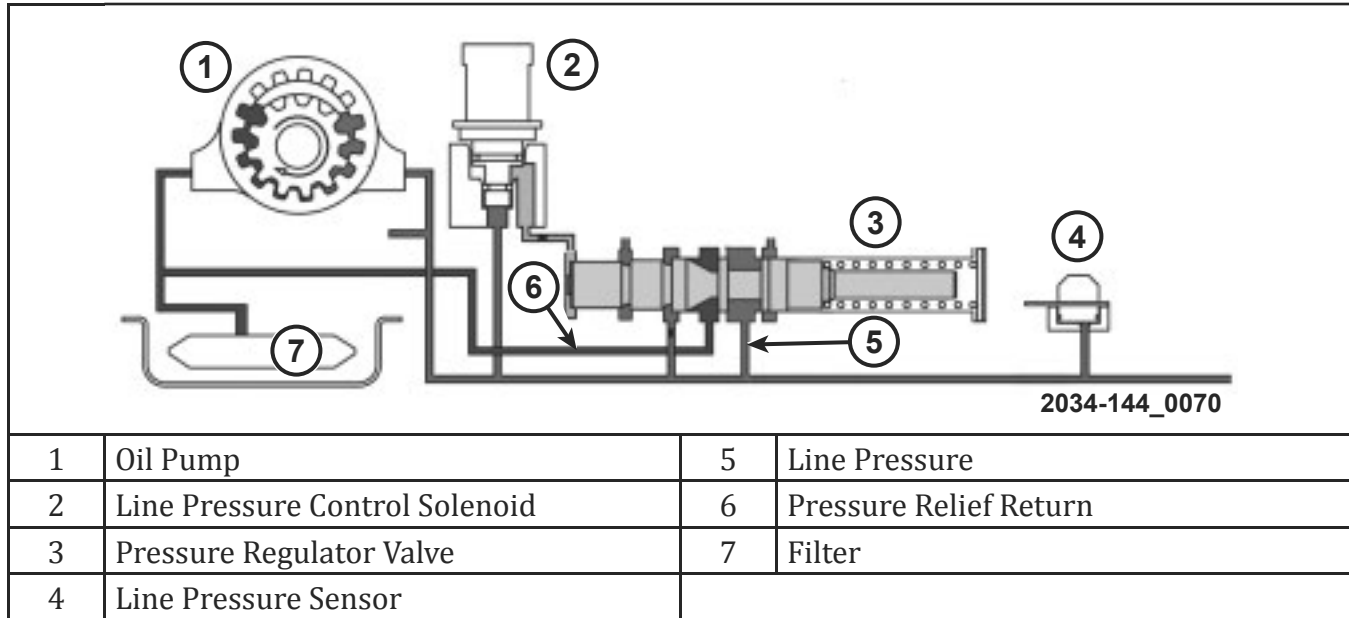

Figure 63 Line Pressure Maximum - 62TE

Typical components of the line pressure control system are:

- Line pressure regulator valve
- Pressure control solenoid
- Line pressure sensor

Typically, transmission line pressure is line regulated above 100 psi. Pressure this high is frequently needed by the transmission, but not all of the time. The higher that line pressure gets, the harder the oil pump must work to create these pressures. Because the oil pump is driven by the engine, by way of the torque converter housing, it robs engine power (parasitic loss) that could be better used for transmitting engine torque to the drive wheels. Parasitic losses lower fuel economy. Variable line pressure allows the TCM to control line pressure using a variable force solenoid.

Closed-Loop Line Pressure Control (continued)

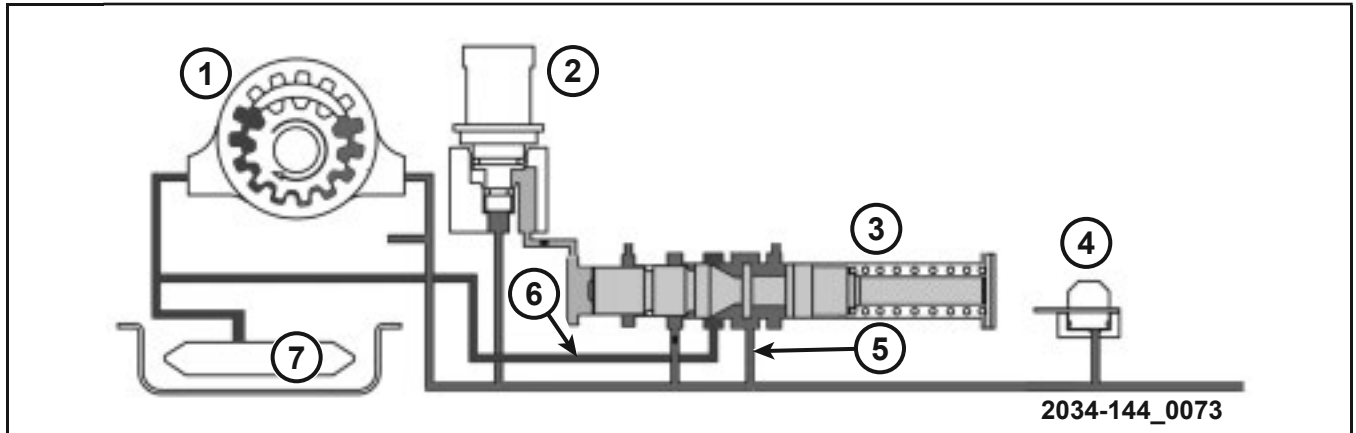

1	Oil Pump	5	Line Pressure
2	Line Pressure Control Solenoid	6	Pressure Relief Return
3	Pressure Regulator Valve	7	Filter
4	Line Pressure Sensor		

Figure 64 Line Pressure Minimum - 62TE

The line pressure sensor informs the TCM of what actual line pressure is, and then the TCM bases the control of the pressure control solenoid on the difference between desired and actual line pressure. The pressure control solenoid sends a control pressure to the end of the regulator valve away from spring pressure. This pressure tips the regulator valve balance, giving transmission electronics full control of line pressure. The control is visible in terms of duty cycle. The higher the solenoid duty cycle, the higher the signal pressure against the end of the valve, resulting in lower line pressure. The lower the solenoid duty cycle, the lower the signal pressure against the end of the valve, resulting in higher line pressure.

- Low solenoid duty cycle = high line pressure
- High solenoid duty cycle = low line pressure

Default Line Pressure Control

When electrical power is removed from the line pressure solenoid (limp-in mode), the pressure regulator valve defaults to its normal mechanical state.

With no regulated pressure signal from the line pressure solenoid, the line pressure regulator valve mechanically controls line pressure with spring force.

Open-Loop Line Pressure Control

Open-loop line pressure control systems, such as those used on the 6F24, AW60T, 8HP45, and 948TE transmissions, do not include a line pressure sensor. Instead, the TCM relies on calculated pressures. In these systems, transmission oil temperature and speed sensor readings are even more critical than usual.

In the absence of direct sensor feedback for line pressure, the TCM cannot set a fault code to indicate pressure regulation performance problems. Instead, pressure regulation faults may be identified by the presence of multiple gear ratio faults, indicating a problem that affects the entire system.

FLUID PUMP NOISE DIAGNOSIS

Fluid Pump Noise

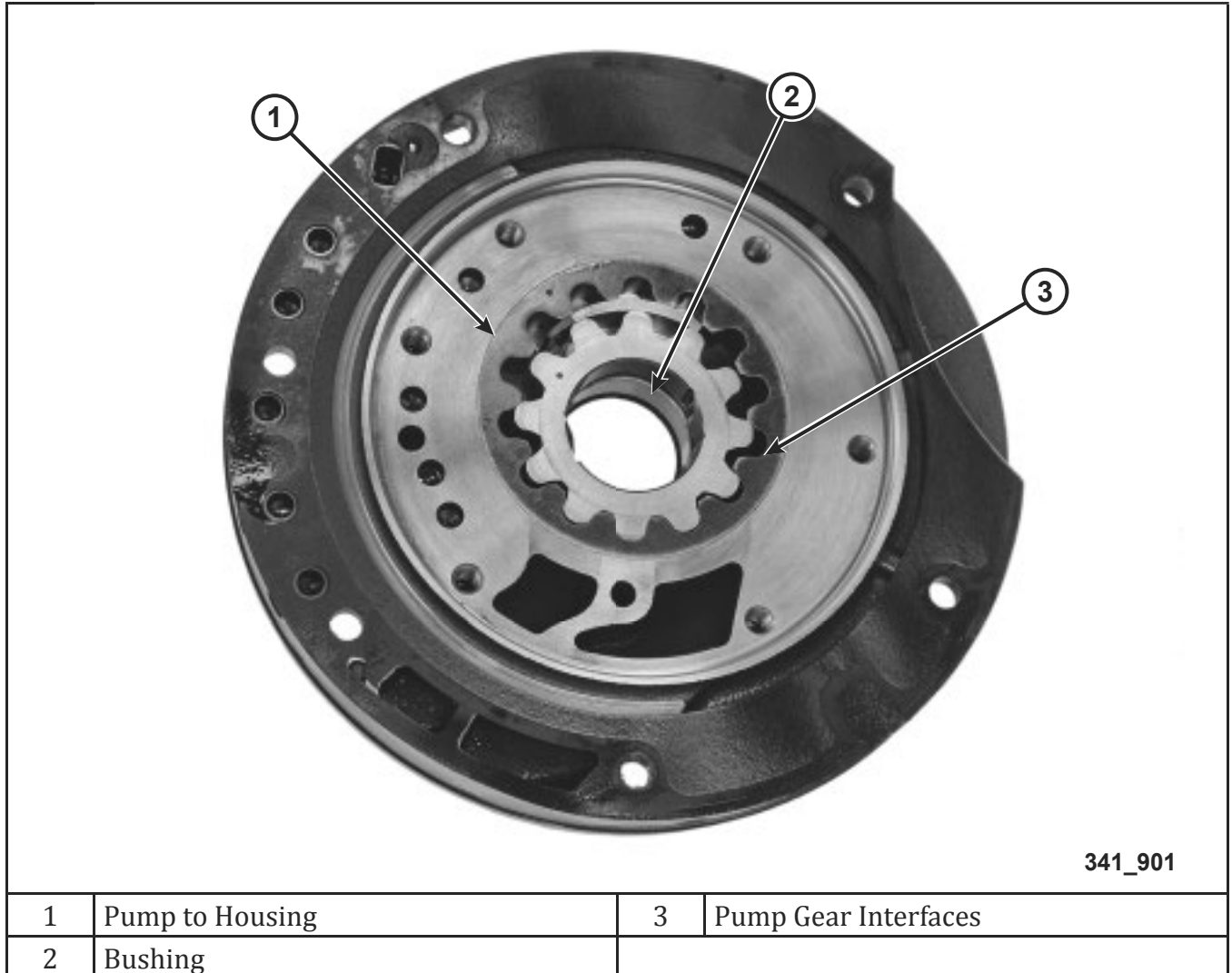

Figure 65 Areas of Wear that Can Cause Fluid Pump Noise

The fluid pump is driven at engine speed and any noise generated within the pump is directly related to engine speed. Typically, as the engine speed increases, the pump noise increases. Noise generated by damage within the pump is present any time the engine is running. The noise does not change with gear ratio.

Pump noise can also change with the hydraulic load on the pump. If line pressure is commanded to maximum, the pump is forced to work harder and generally the intensity of the noise increases.

Another common cause of pump related noise is cavitation. This is where air is drawn into the inlet of the pump. Low fluid level or a broken filter can allow cavitation.

ACTIVITY 7 PUMP REMOVAL

Instructions: Perform the pump removal procedure using service information, and answer the questions below.

1. Position the transaxle so the side pan is vertical. Install the slide hammers, C-3752 and adapters as shown in the graphic below.
2. Screw in the adapters and attach the slide hammers.
3. Remove the oil pump assembly using the two slide hammers.
4. Use the slide hammers at the same time until the pump comes out.



Pump Removal

Instructions: Using the hydraulic schematics in service information, answer the following question:

5. Remove the cooler bypass valve (1).
 - a. What is the purpose of the cooler bypass valve on this transmission?



DEMONSTRATION 4 FLUID PUMP COMPONENTS

Instructions: This demonstration ensures familiarity with the components of the fluid pump. This page is primarily for notes and has key questions on the topic.

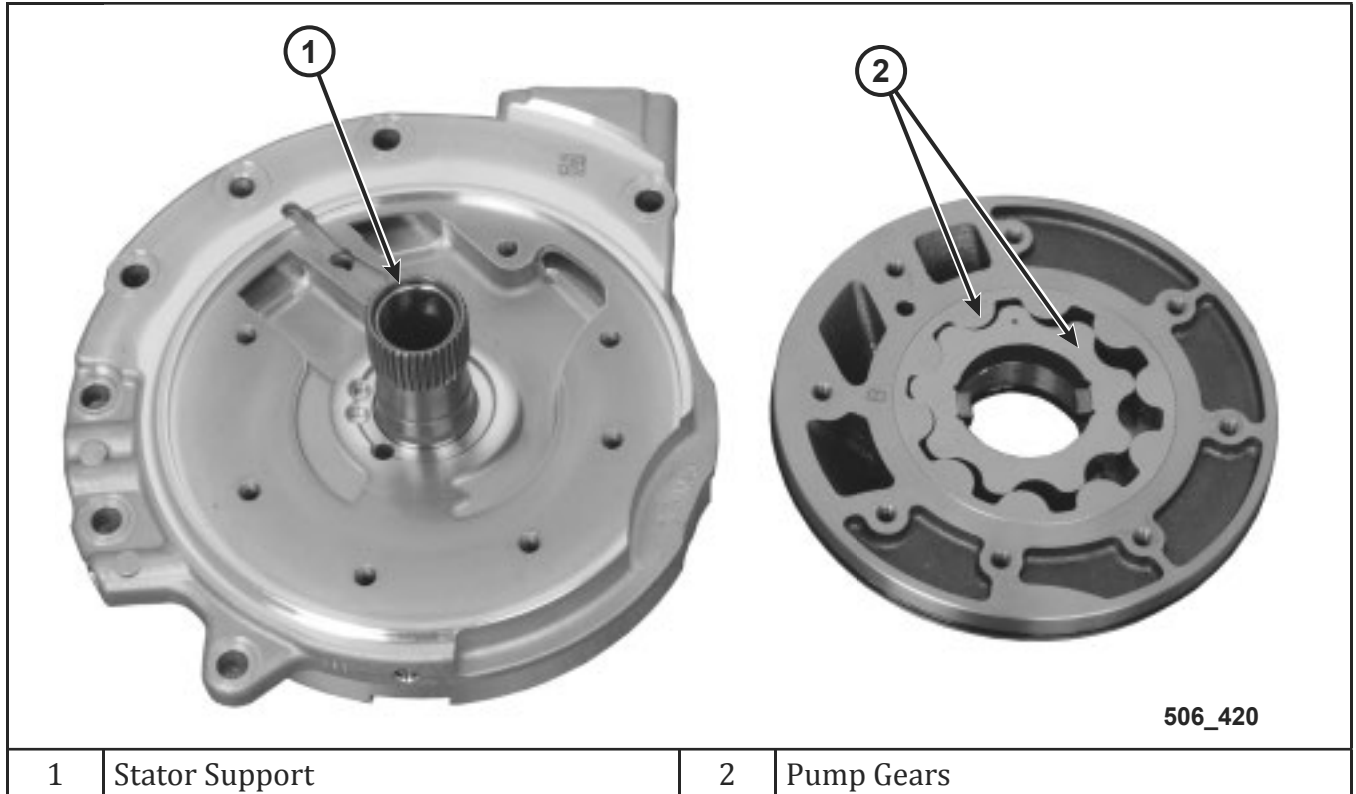

1. What is the function of the components shown in the photo?

2. What is the function of the component with callout 1?

Fluid Pump Components

3. What is the function of the component with callout 2 shown in the photo?

4. What drives the components shown in the photo?



ACTIVITY 8 FLUID PUMP MECHANICAL DIAGNOSIS

TASK ONE: SLOW ENGAGEMENT INTO REVERSE AND DRIVE

NORMAL OPERATION

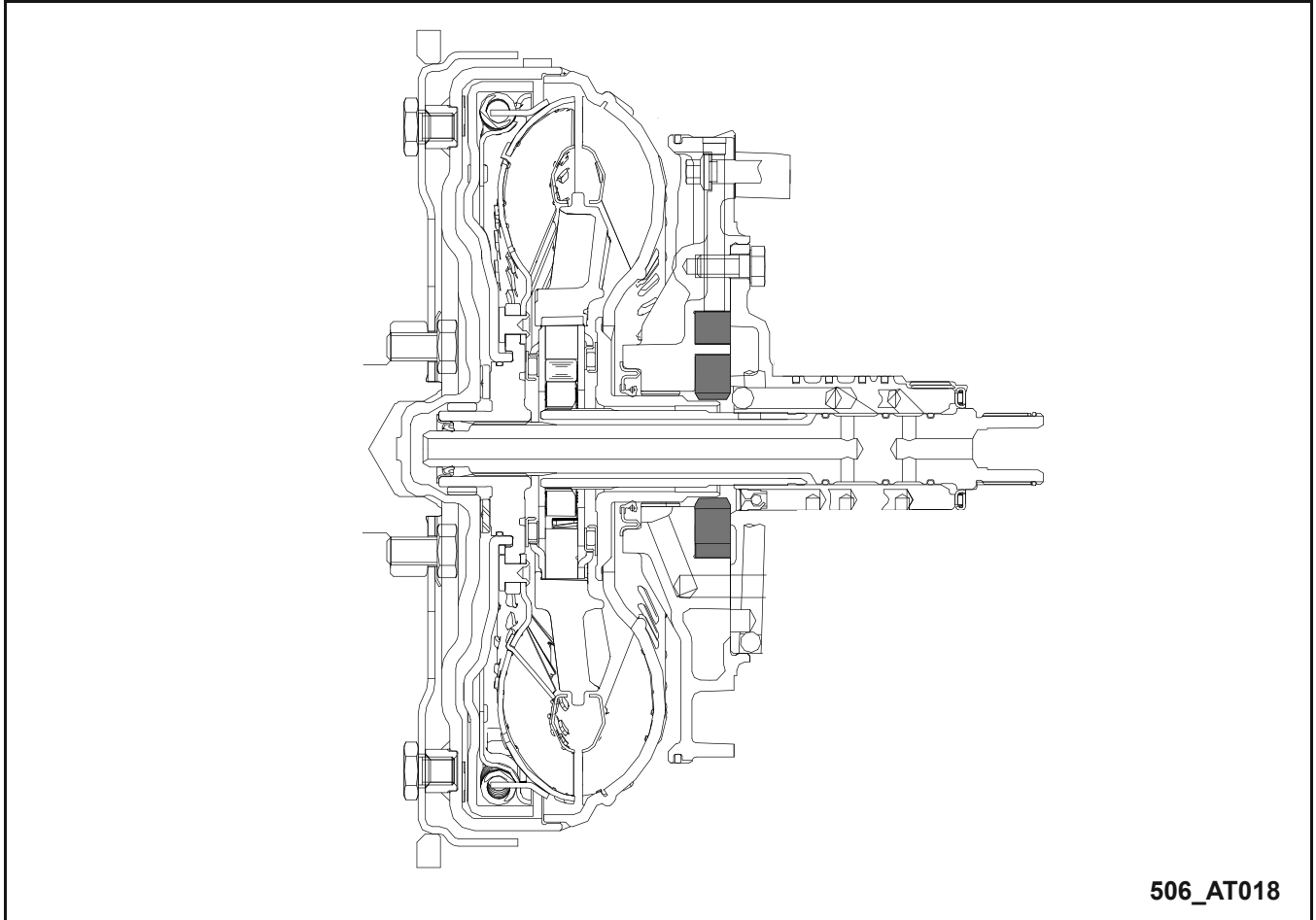

1. At what speed is the fluid pump driven?

2. Will the output of the fluid pump vary?

Fluid Pump Mechanical Diagnosis

3. If the fluid pump output varies, when is the output highest?

4. Does the output of the fluid pump affect the transmission at a system level (all operation) or component level (only specific components)?



DIAGNOSIS

Instructions: Answer the following questions related to diagnosing a fluid pump symptom. The concern is a vehicle that has slow engagements in Reverse and Drive, and also has soft and slipping shifts through the forward gears.

5. What mechanically can cause a fluid pump to perform poorly (reduced output)?

6. How could a poorly performing fluid pump result in the symptom?

7. What components in the inlet side of the pump could reduce fluid pump output? How?

ACTIVITY 9 FLUID PUMP HYDRAULIC DIAGNOSIS

TASK ONE: TRANSMISSION HAS SLOW ENGAGEMENTS AND SOFT SHIFTS IN ALL GEARS

COMPONENTS

- Using service information for a 2012 RT vehicle application, identify the components by placing the corresponding numbers in the table below the graphic.

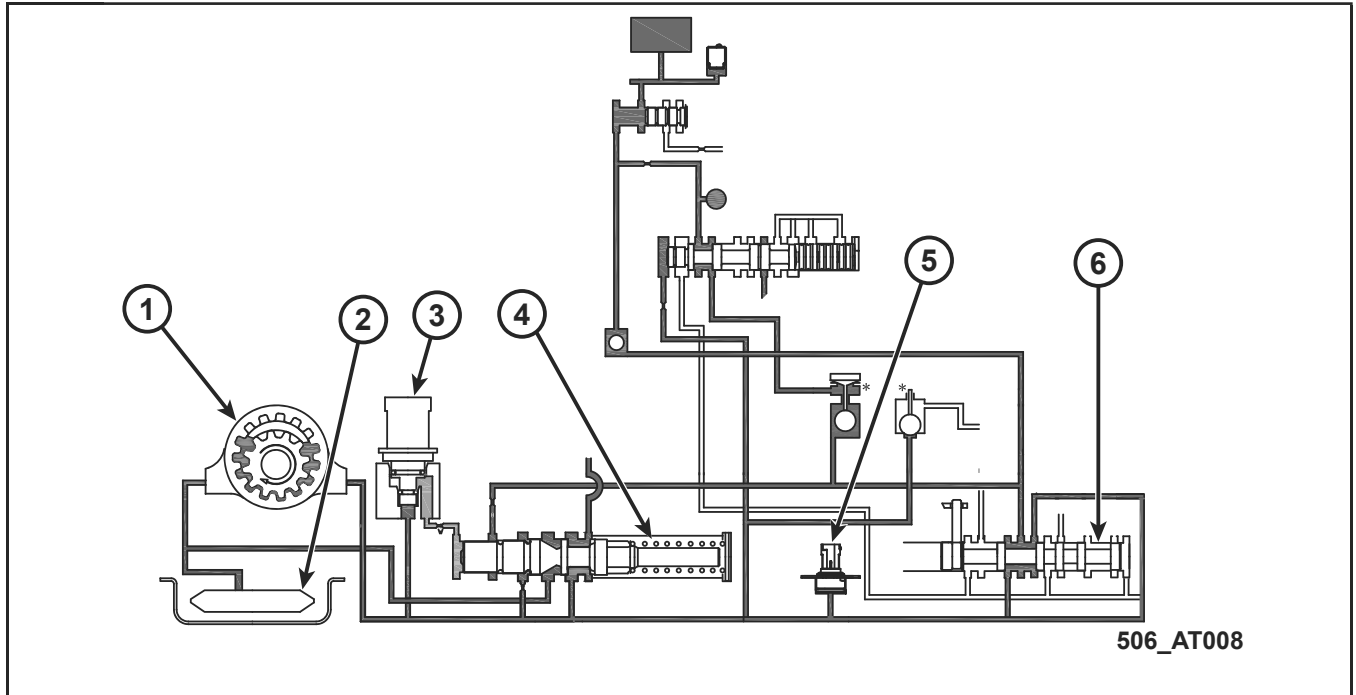

	Fluid Pump		Pressure Regulator Valve
	Filter		Line Pressure Sensor
	Pressure Control Solenoid		Manual Valve



Fluid Pump Hydraulic Diagnosis

NORMAL OPERATION

2. Identify the fluid flow paths by placing the corresponding numbers in the table below the graphic.

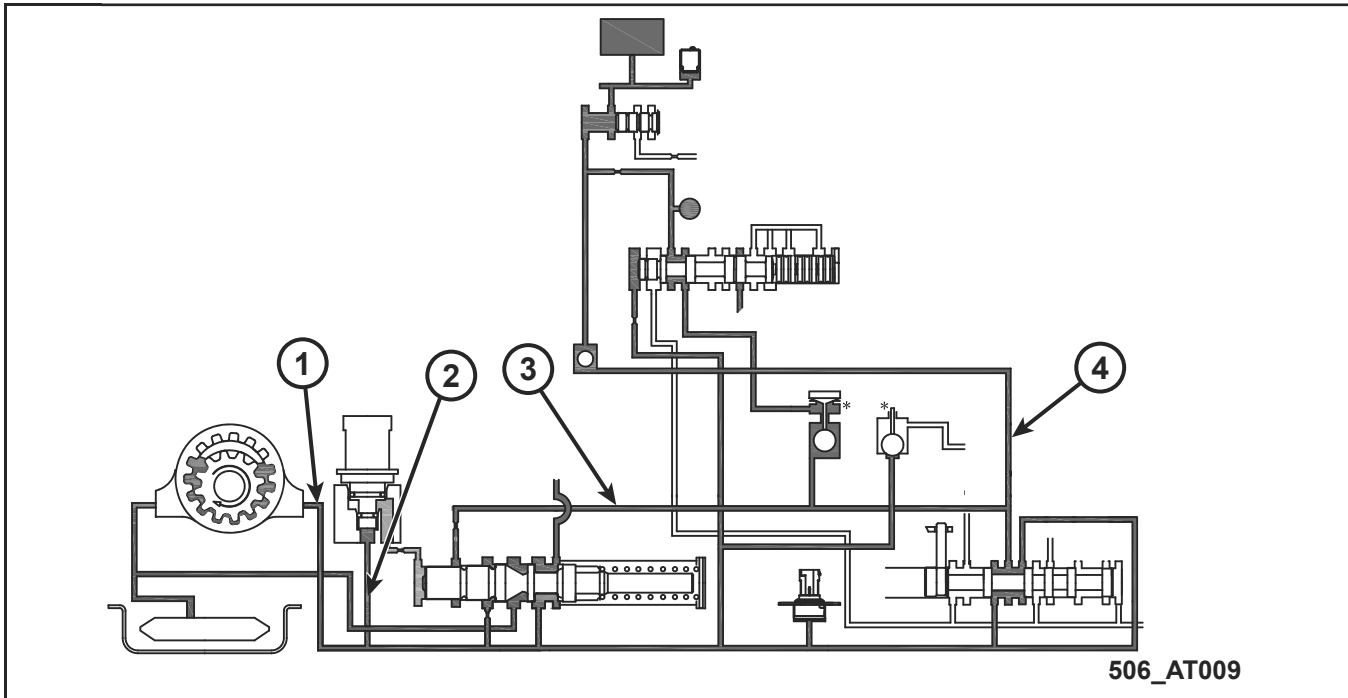

From Pump out to Manual Valve	Manual Valve out to Pressure Regulator Valve
Pump out to Pressure Control Solenoid	From Manual Valve out to Clutch Control

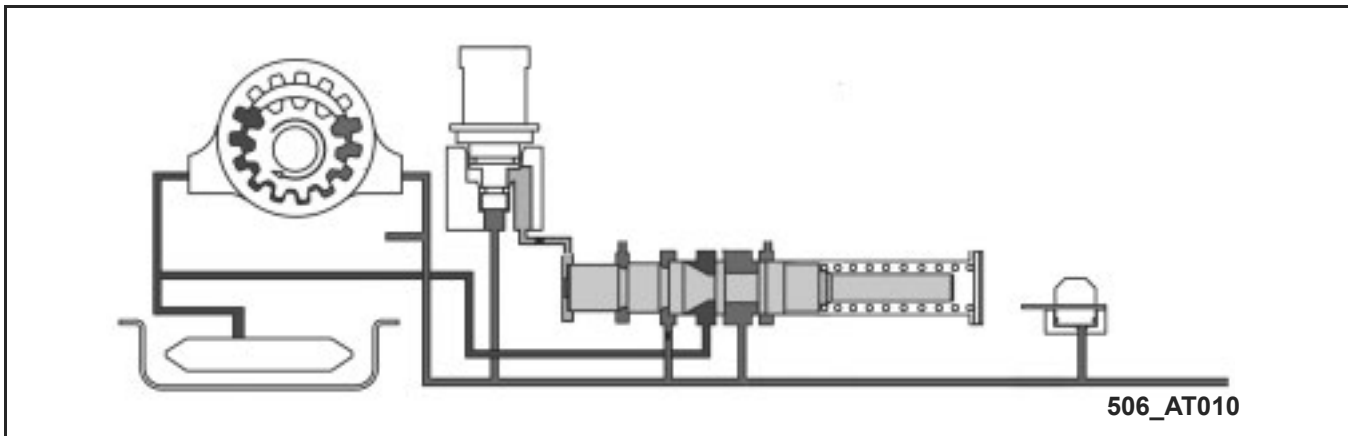

3. Does the illustration above show the pressure regulator valve position for high or low pressure?

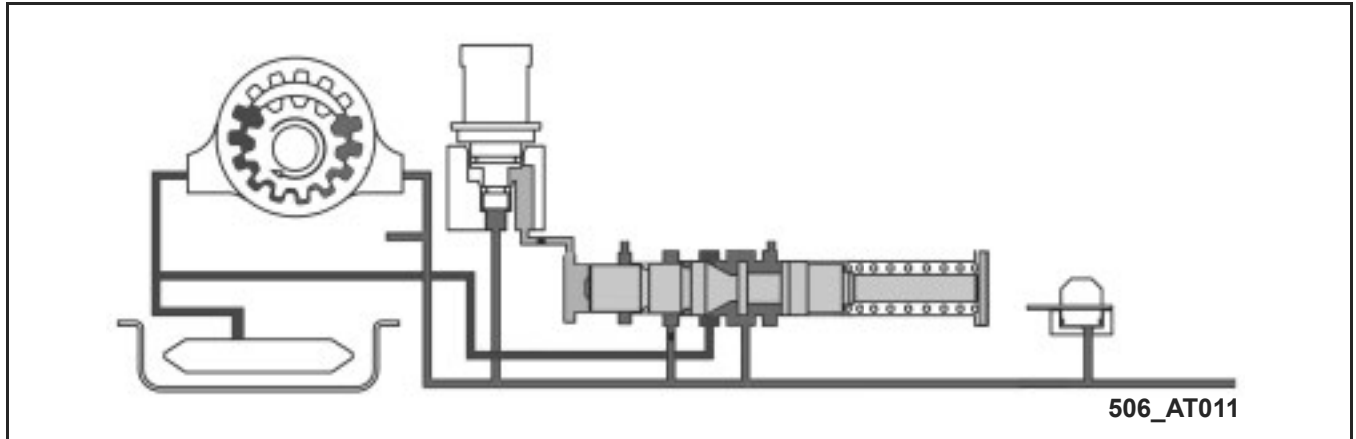

4. Does the illustration above show the pressure regulator valve position for high or low pressure?

5. If the pump is a fixed displacement volume, how can the regulator valve control the pressure in the hydraulic system?

6. What is the purpose of the spring at the end of the pressure regulator valve?

7. What would happen to the line pressure if the spring was weak or broken?



Fluid Pump Hydraulic Diagnosis

DIAGNOSIS

Instructions: Answer the following questions related to diagnosing a fluid pump symptom. The concern is a vehicle that has slow engagements in Reverse and Drive, and also has soft and slipping shifts through the forward gears.

8. If a DTC for clutch slipping is present, and a line pressure check indicates low fluid pressure, does this further support a broken spring? Why?

9. Based on the symptom provided, is the concern related to high or low system pressure?

10. If the scan tool can be used to command the line pressure solenoid through a range of mA, does this help eliminate any potential causes for the concern?

11. What, besides the pump itself, could cause low line pressure?



TASK TWO: TRANSMISSION HAS HARSH ENGAGEMENTS AND HARSH SHIFTS IN ALL GEARS

NORMAL OPERATION

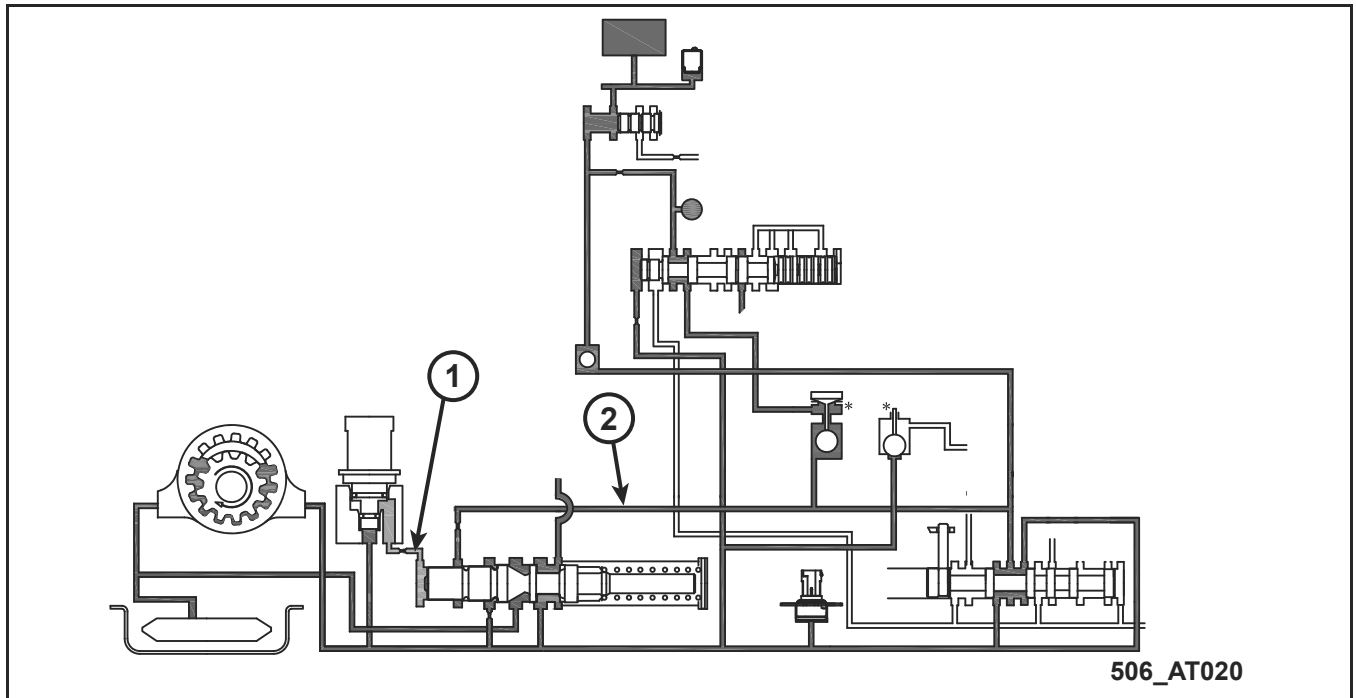

1. What is the function of the circuit identified as number one on the graphic that goes from the pressure control solenoid to the pressure regulator valve?

2. What is the function of the circuit identified as number two on the graphic that goes from the manual valve to the pressure regulator?

3. If the line pressure control solenoid was plugged and could not provide fluid to the pressure regulator, what would be the resulting pressure?

4. What is the purpose of defaulting to maximum line pressure?



Fluid Pump Hydraulic Diagnosis

DIAGNOSIS

Instructions: Answer the following questions related to diagnosing a vehicle that has harsh engagements in Reverse and Drive, and also has harsh shifts through the forward gears.

5. Based on the symptom provided, is the concern related to high or low system pressure?

6. Why would the state of the line pressure cause the concern?

7. If during diagnostics you find that the pressure control solenoid is functioning properly electrically, could the pressure regulator valve cause the condition and why?



ACTIVITY 10 FLUID PUMP NOISE DIAGNOSIS

Instructions: Answer the following questions on pump noise.

1. In general, is pump noise related to changes in engine speed, vehicle speed, or gear ratio? Circle/check mark all that apply.

<input type="checkbox"/>	Engine speed	<input type="checkbox"/>	Gear ratio
<input type="checkbox"/>	Vehicle speed		

2. In general when does pump noise increase?
-

3. Indicate in which gear ranges pump noise will typically be present. Circle/check mark all that apply.

<input type="checkbox"/>	Park	<input type="checkbox"/>	Neutral
<input type="checkbox"/>	Reverse	<input type="checkbox"/>	Drive

4. What can cause the fluid pump to cavitate.
-

5. Could a noise occur if the pump gears were not reassembled correctly?
-



LESSON 5 GEARSETS

PLANETARY GEARSETS

Simple Planetary Gearset

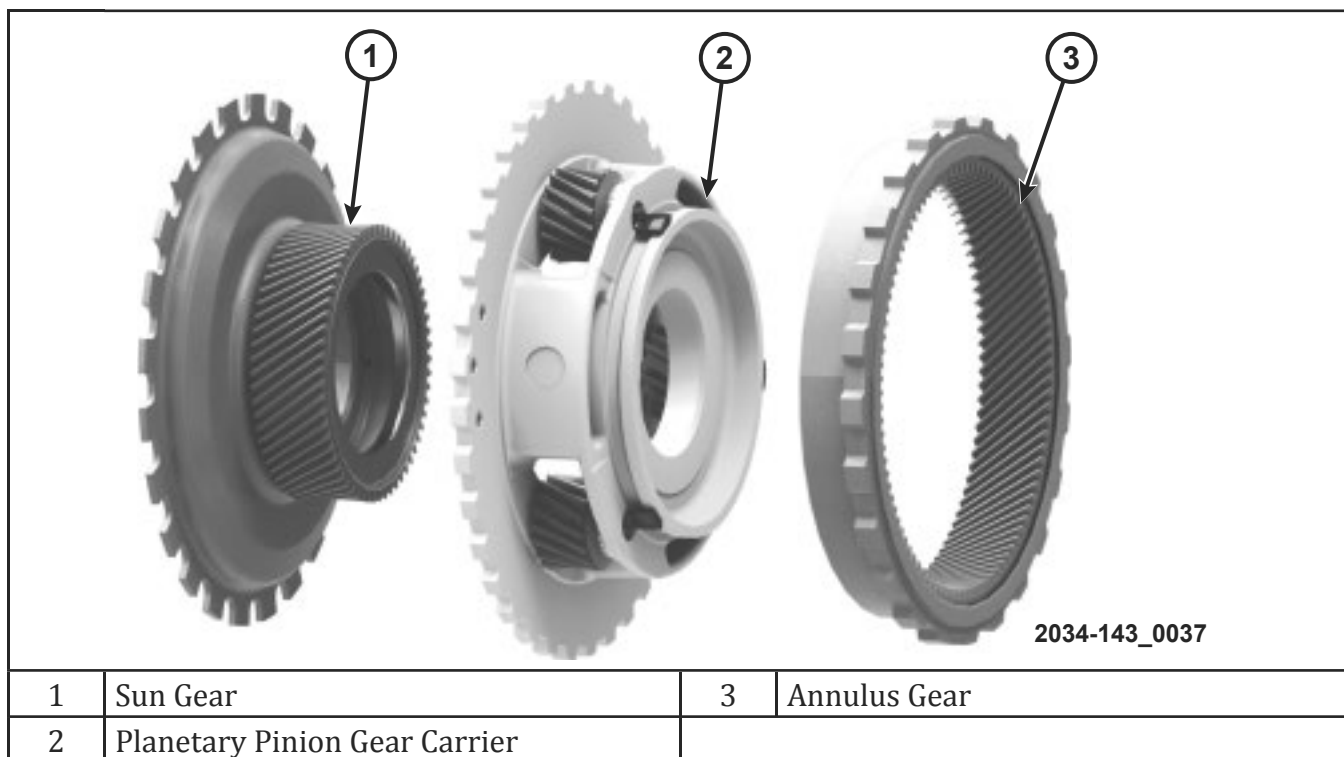

Figure 66 Simple Gearset

Conventional automatic transmissions use simple planetary gearsets or a combination of simple gearsets—referred to as a compound gearset—to transmit torque while changing ratios. The simple planetary gearset is a series of three interconnecting gears consisting of a sun gear, several pinion gears, and an annulus (ring) gear. Each pinion gear is mounted to a carrier assembly by a welded pinion shaft. The sun gear is at the center of the assembly. The pinion gears rotate around the sun gear and the annulus gear surrounds the pinion gears. The name planetary fits because the pinion gears resemble planets revolving around the sun. A manual transmission requires two or three gear shafts to transmit torque in various ratios. A simple planetary gearset is capable of generating five forward and two reverse gear ratios and permits torque transfer through the automatic transmission on one shaft axis.

Simpson Planetary Gearset



Figure 67 Simpson Gearset (8HP45 P1/P2 shown)

A popular type of compound gearset is known as the Simpson gearset. The Simpson gearset is a combination of two simple gearsets that share a common sun gear. The two sun gears, although different size and tooth count, are welded together and rotate at the same speed.

Ravigneaux Planetary Gearset

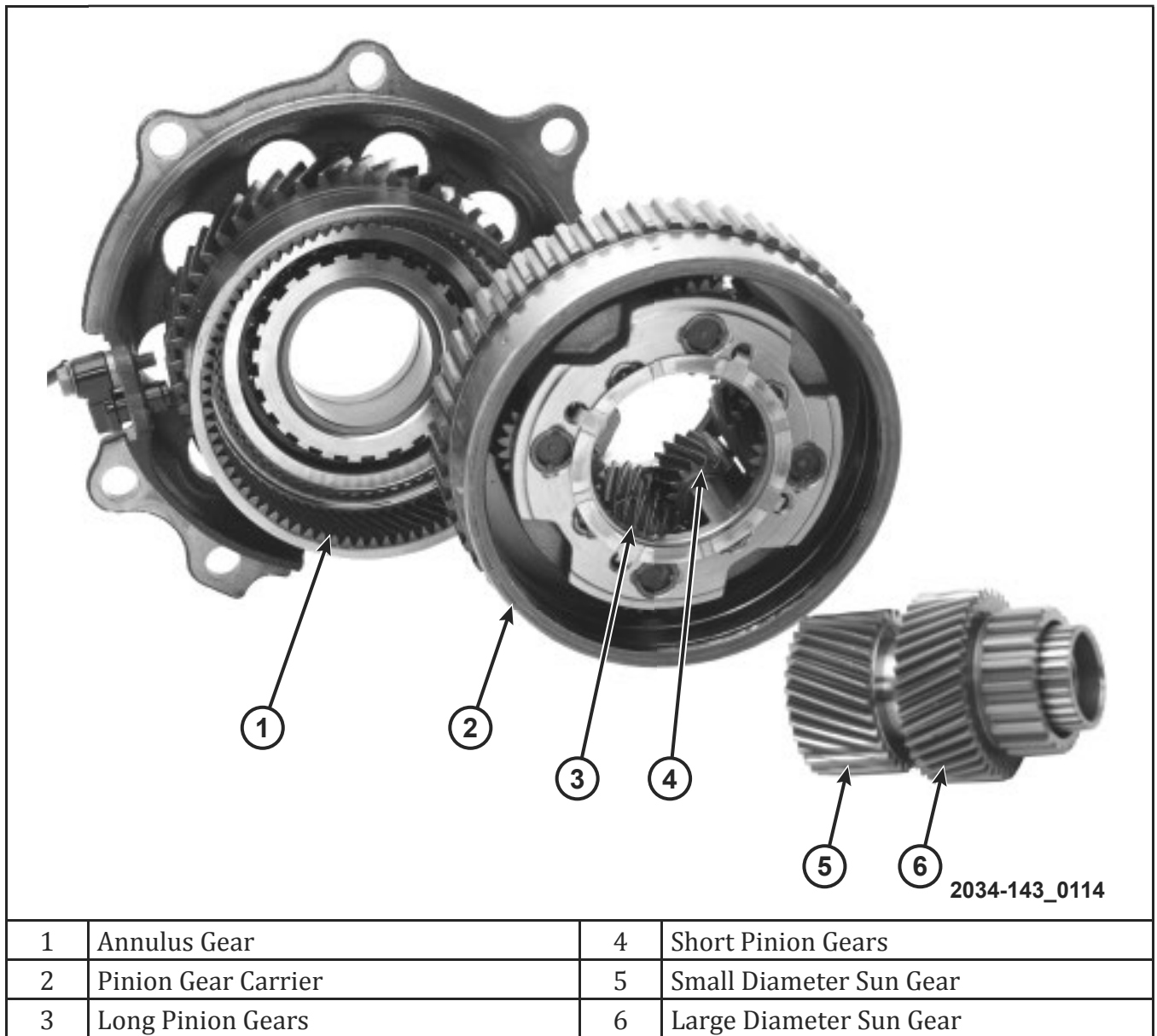

Figure 68 Ravigneaux Gearset

The Ravigneaux gearset contains two sun gears, two sets of planetary pinion gears, and one annulus gear. The large diameter sun gear reacts with the long set of pinion gears, while the small diameter sun gear reacts with the short set of pinion gears. The planetary pinion gears are contained in one planetary pinion carrier assembly.

Compounded Planetary Gearset

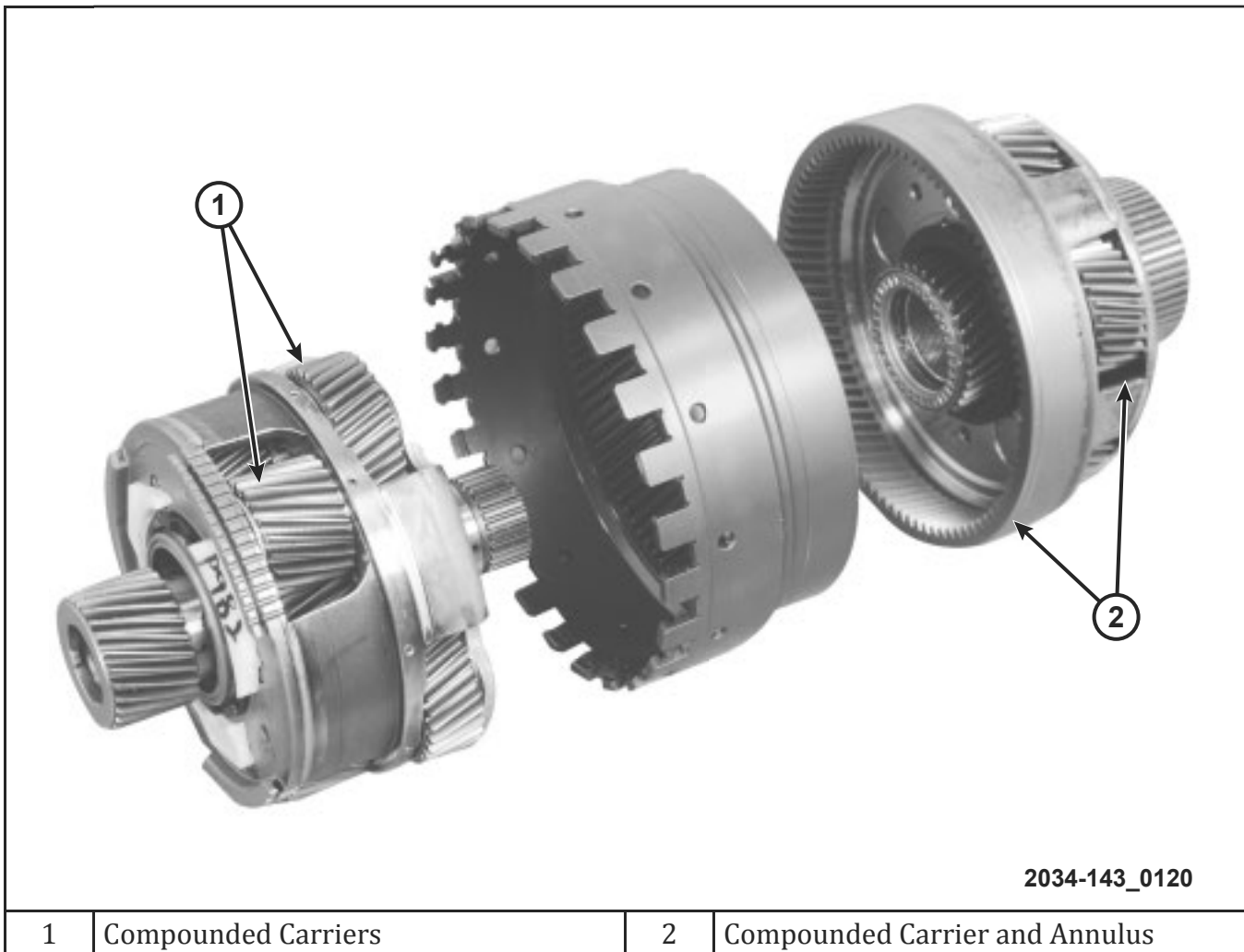

Figure 69 Compounded Gearset

The compounded gearset is a combination of two or three simple gearsets sandwiched together and interconnected through various planetary members. For example, the planetary pinion carrier of the first gearset is welded to the annulus in the second gearset so that when the carrier rotates, so does the annulus at the same speed.

PLANETARY GEARSET POWERFLOW

Power is transferred through planetary gearsets by holding one part of the gearset and driving another part. Power exits the third part of the gearset. For example, holding the sun gear and driving the planet carrier causes the annulus to rotate.

With regard to the direction of rotation, it is helpful to remember two points:

- Two gears with external teeth in mesh rotate in opposite directions.
- Two gears in mesh—one with internal teeth and one with external teeth—rotate in the same direction.

Different combinations of driven gears and held gears produce different gear ratios or actions. By holding or driving the gears of a planetary gearset, it is possible to obtain:

- Speed reduction (torque multiplication)
- Overdrive (speed multiplication)
- Reverse
- Direct

NOTE: Gear ratios are dependent on the number of teeth on the sun gear and annulus gear in every planetary gearset.

Direct drive is achieved by driving two members of a planetary gearset at the same speed. Neutral can be achieved by not holding or driving any one member of the planetary gearset.

Two members of a planetary gearset can be driven at different speeds to achieve yet another output ratio. This is done in the newer 8- and 9-speed transmissions.

Calculating Gear Ratio

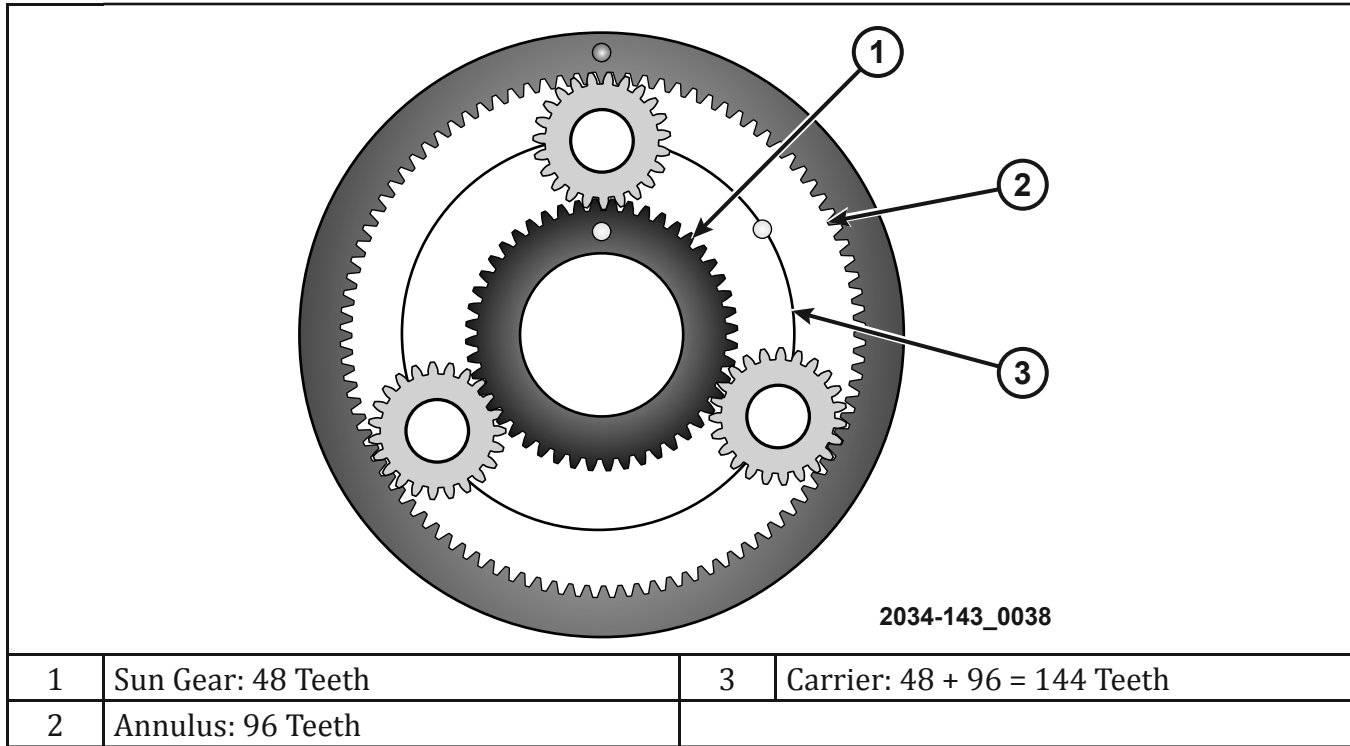

Figure 70 Simple Planetary Gear Ratios

The carrier is the largest gear with the most teeth. The theoretical number of teeth on the carrier can be determined by adding the tooth count from the sun and annulus gears.

The sun gear is the smallest gear with the least number of teeth.

The annulus gear tooth count is always bigger than the sun gear, but smaller than the carrier tooth count.

The number of teeth on the planet gears is not used to calculate gear ratios, only the theoretical number of carrier teeth. When the number of teeth is known, the gear ratio is determined by:

- $\text{Number of teeth on output} / \text{Number of teeth on input} = \text{Ratio}$

Gear Reduction

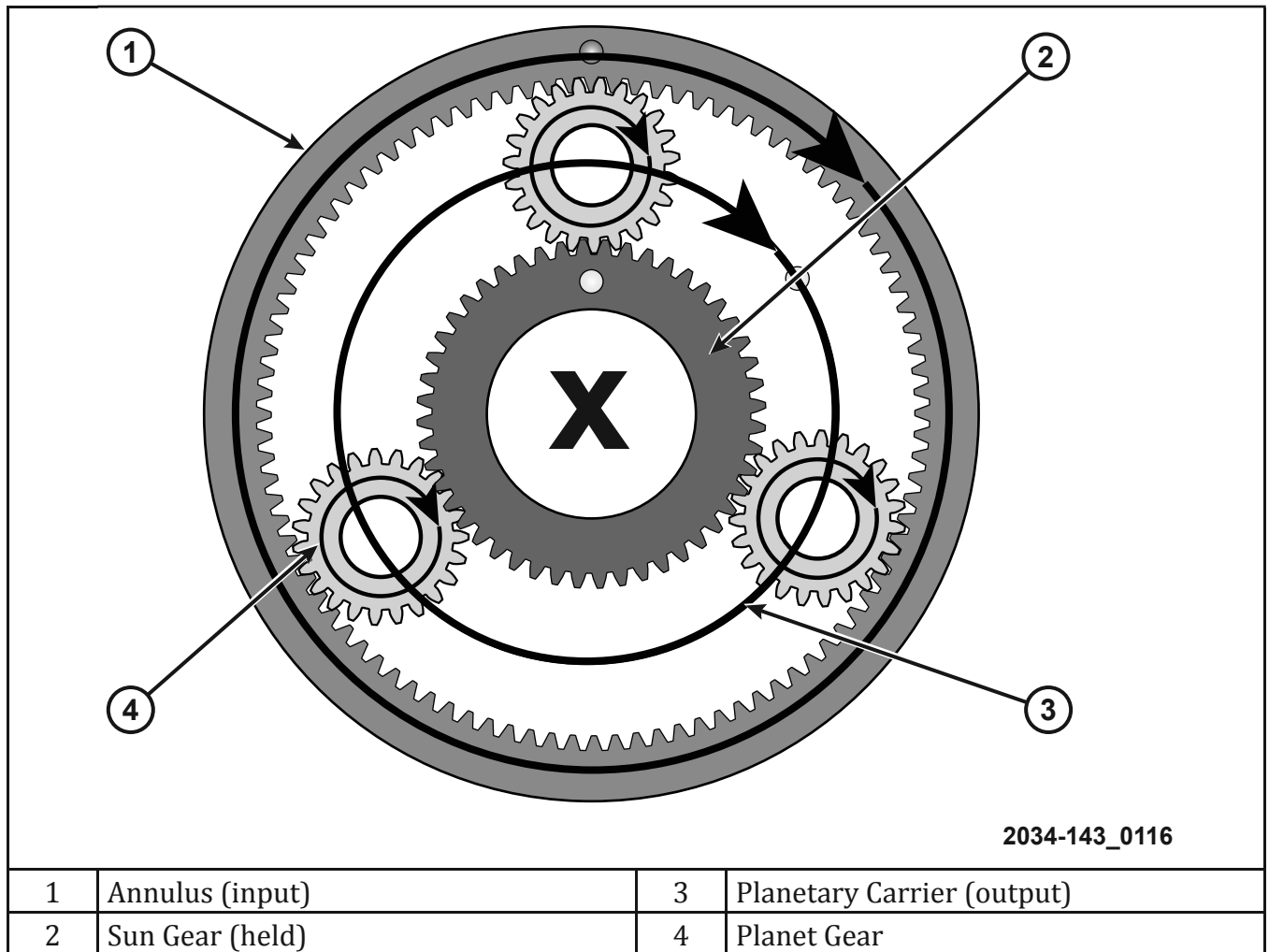

Figure 71 Gear Reduction

Through planetary gearsets, automatic transmissions can achieve gear reduction. Gear reduction provides increased torque accompanied by reduced output speed. One method of obtaining a gear reduction is to drive the sun gear and hold the annulus stationary. Another method is to hold the sun gear stationary while driving the annulus gear. In both cases, the planetary carrier is the output.

The first method provides the maximum speed reduction (torque multiplication) that can be achieved in one planetary gearset. The second method produces minimum gear reduction.

Direct Drive

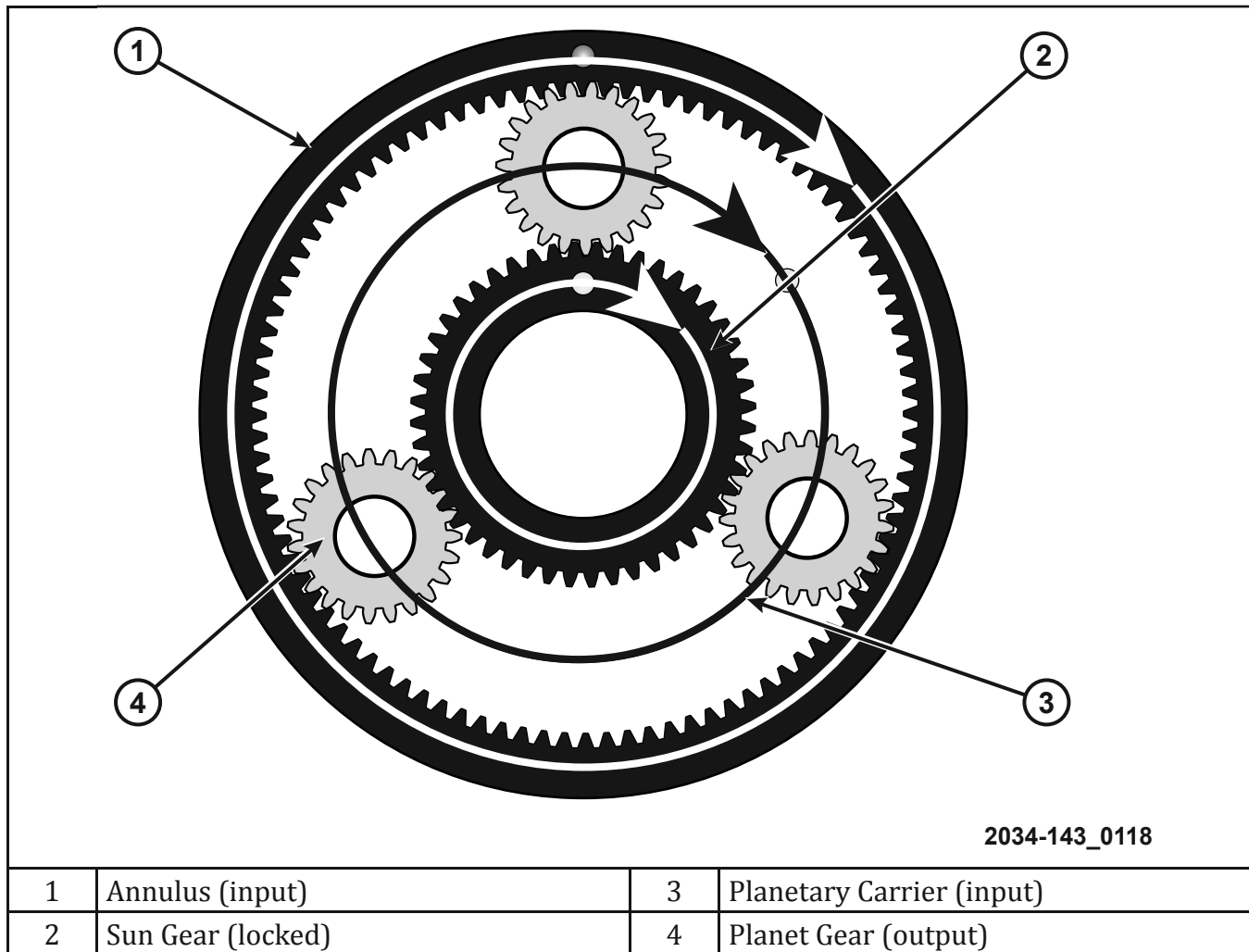

Figure 72 Direct Drive

In direct drive, the gearset acts as a solid unit to transfer power. A planetary gearset acts as one unit while driving two of its members at the same speed. The planet gears do not walk around the sun gear or rotate on their axes. The entire unit is locked together, forming one rotating unit with a 1:1 ratio between the input and the output.

Overdrive

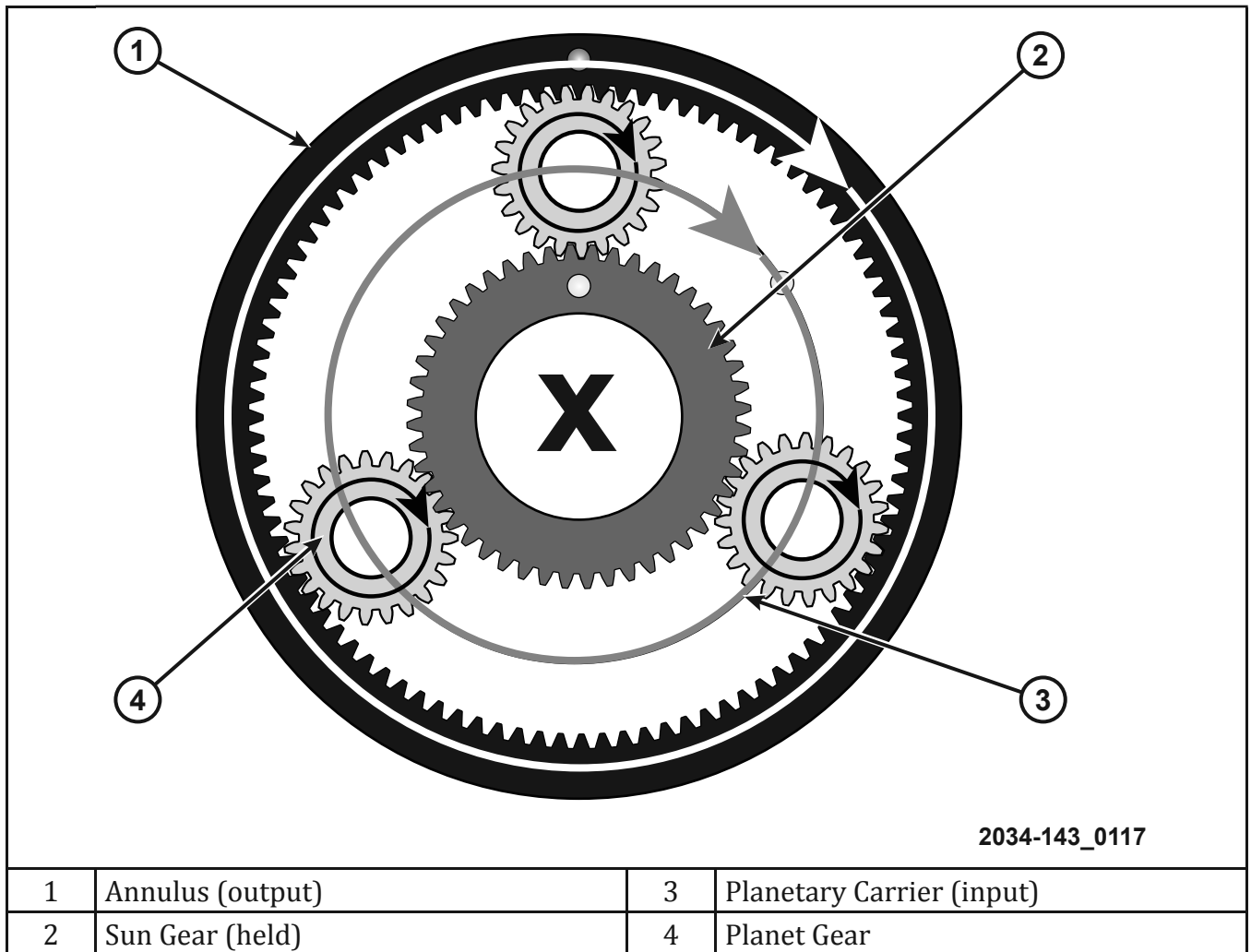
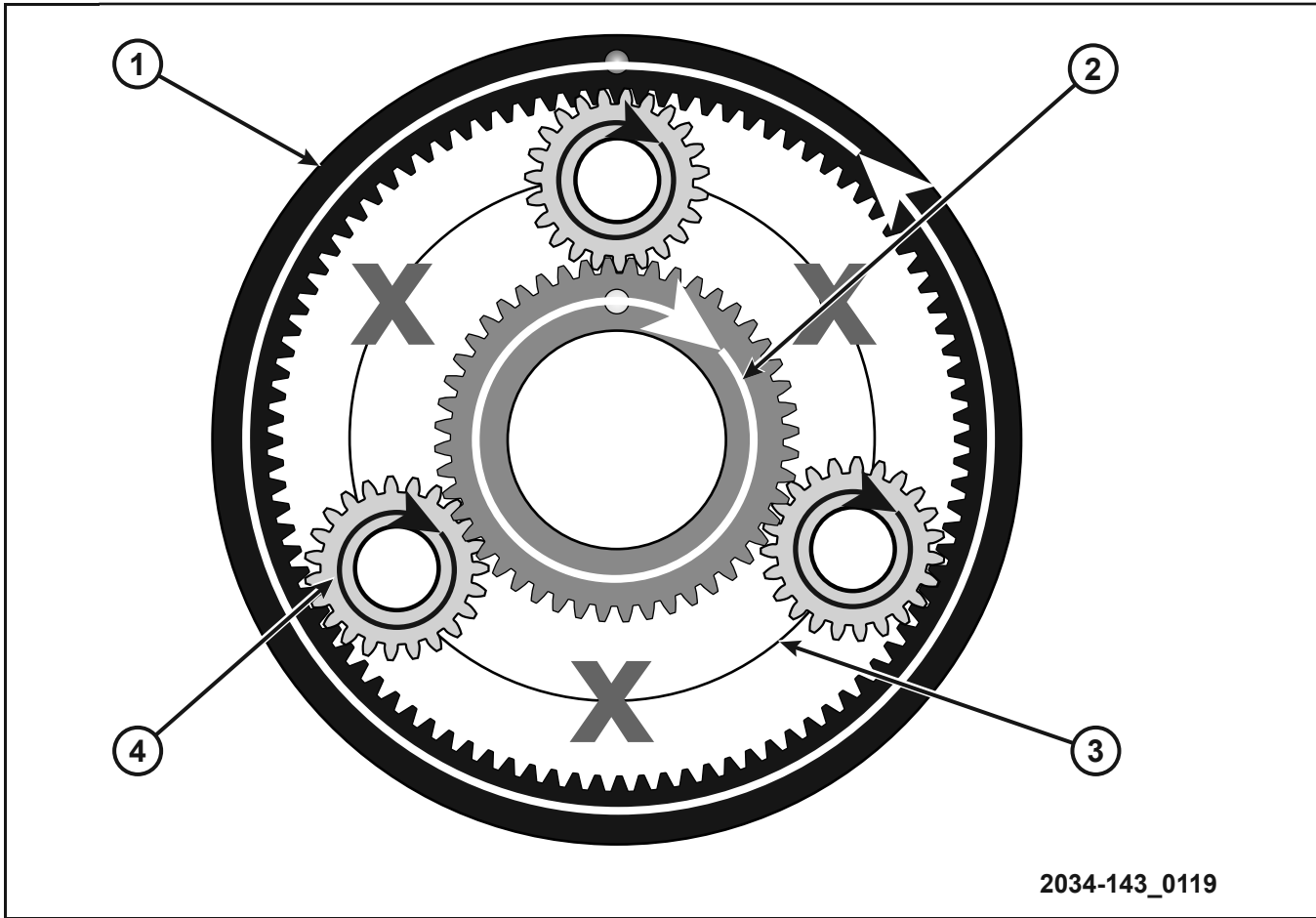

Figure 73 Overdrive

If the sun gear or annulus is held stationary while driving the carrier, the remaining member (output) is driven at a faster speed than the planetary carrier (input). Driving the carrier produces overdrive in a planetary gearset with a maximum speed as a result of holding the annulus stationary.

Reverse



1	Annulus (output)	3	Planetary Carrier (held)
2	Sun Gear (input)	4	Planet Gear

Figure 74 Reverse

A planetary gearset is capable of providing output rotation that is the opposite of input rotation. Holding the planet carrier and driving the sun gear produces Reverse. The annulus is the output and turns in the reverse direction of input.

Table 1 Simple Planetary Gearset Rules

Gear Ratio State		Sun Gear	Annulus Gear	Planetary Carrier
Speed Reduction (Torque Multiplication)	Maximum	Input	Held	Output
	Minimum	Held	Input	Output
Direct Drive		Input Any Two Members		
Overdrive (Speed Multiplication)	Minimum	Held	Output	Input
	Maximum	Output	Held	Input
Reverse	Reduction	Input	Output	Held
	Overdrive	Output	Input	Held

Gearsets

GEARSET LUBRICATION

Lubrication Passages

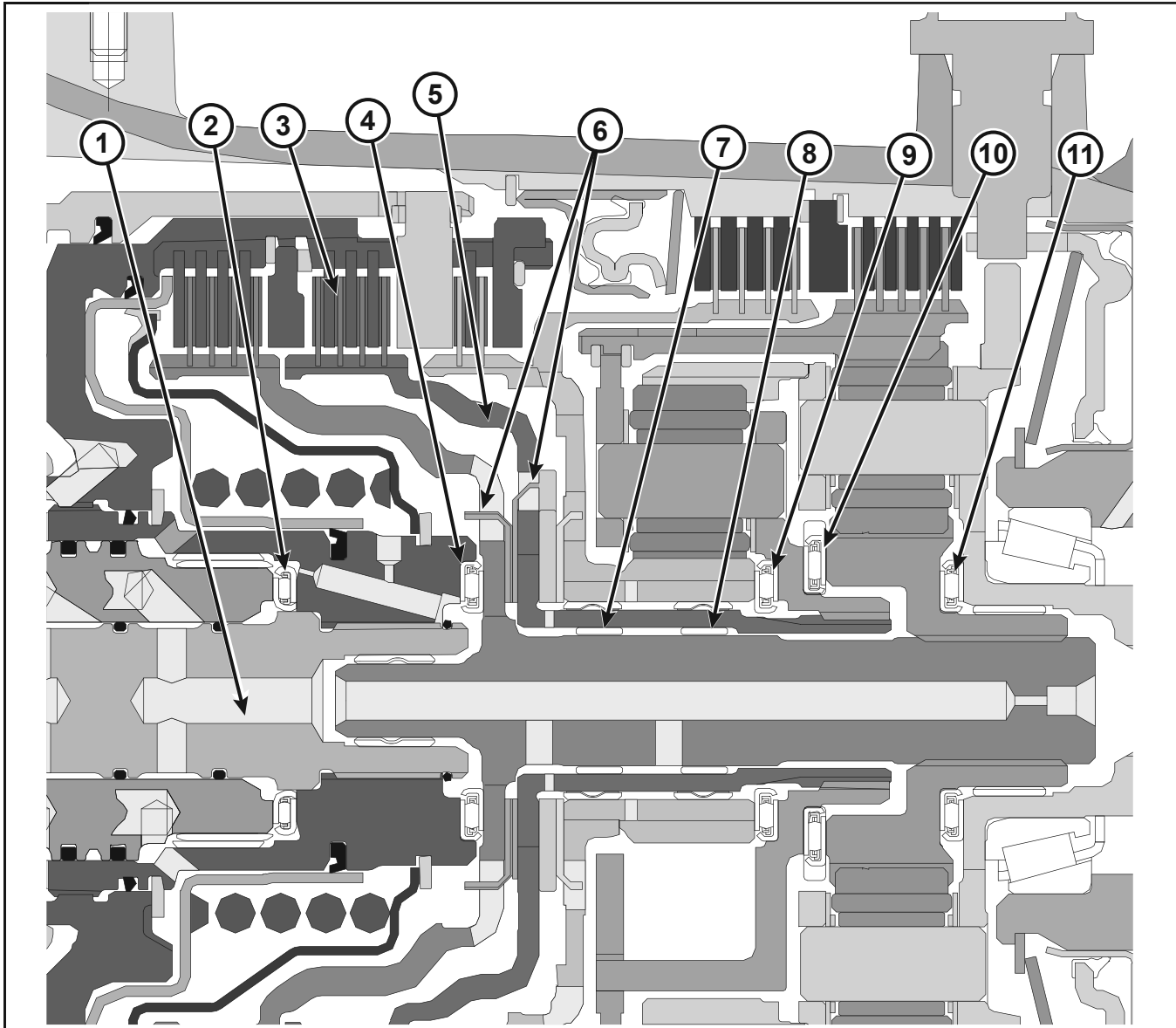

1	Lubrication Main Feed	7	Support Bearings
2	Thrust Bearings	8	Support Bearings
3	Overdrive Clutch	9	Thrust Bearings
4	Thrust Bearings	10	Thrust Bearings
5	Overdrive Hub	11	Thrust Bearings
6	Thrustwashers Between Overdrive and Reverse Hub		

Figure 75 Gearset Lubrication Circuits

Currently, there are two methods to supply fluid flow to the lubrication circuits. The most common method is to direct the returning fluid from the torque converter and cooler directly into the lubrication circuits. This fluid then circulates through the rotating assembly and finally travels to the sump of the transmission. The other method (used on the RFE) supplies the lubrication circuits directly from the line pressure circuit. Both methods achieve the same goal.

Regulated pressurized lubricant from the main line circuit supplies the shafts that the gearsets rotate on.

- Gearsets have orifices to lubricate gearset pinions and bearings.
- Heat is carried away from gearsets by the lubrication fluid.
- Fluid splash from clutches is also a source of gearset lubrication.

PARKING SYSTEMS

Parking System Components

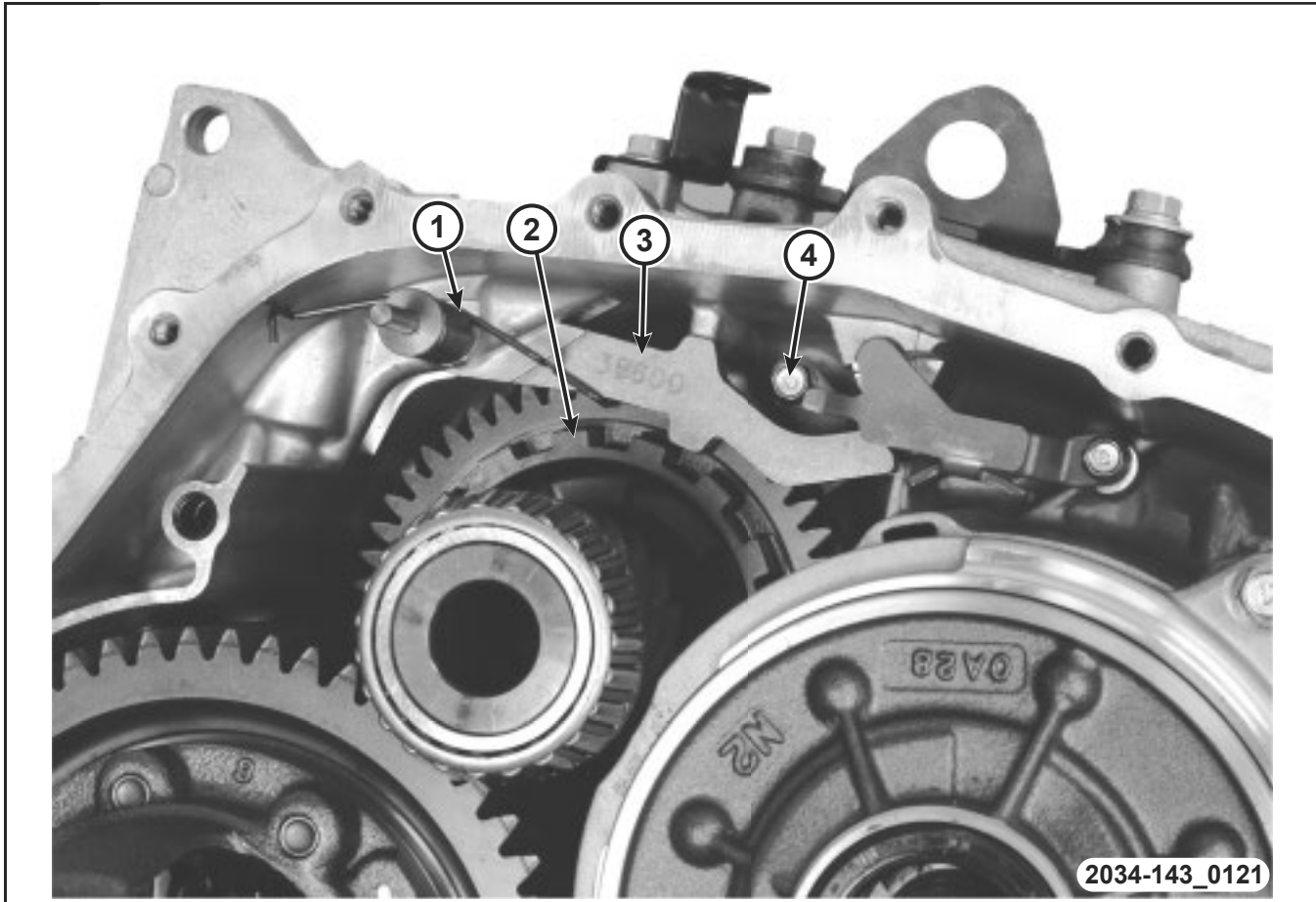

1	Parking Pawl Return Spring	3	Parking Pawl
2	Parking Gear	4	Parking Actuator

Figure 76 Typical Transaxle Park System Components (6F24 shown)

The parking gear has large cog teeth to engage with the pawl. The parking pawl is spring-loaded and moves away from the parking gear when not loaded by the actuator. The guide positions the actuator as it moves into the parking pawl.

Parking System Operation

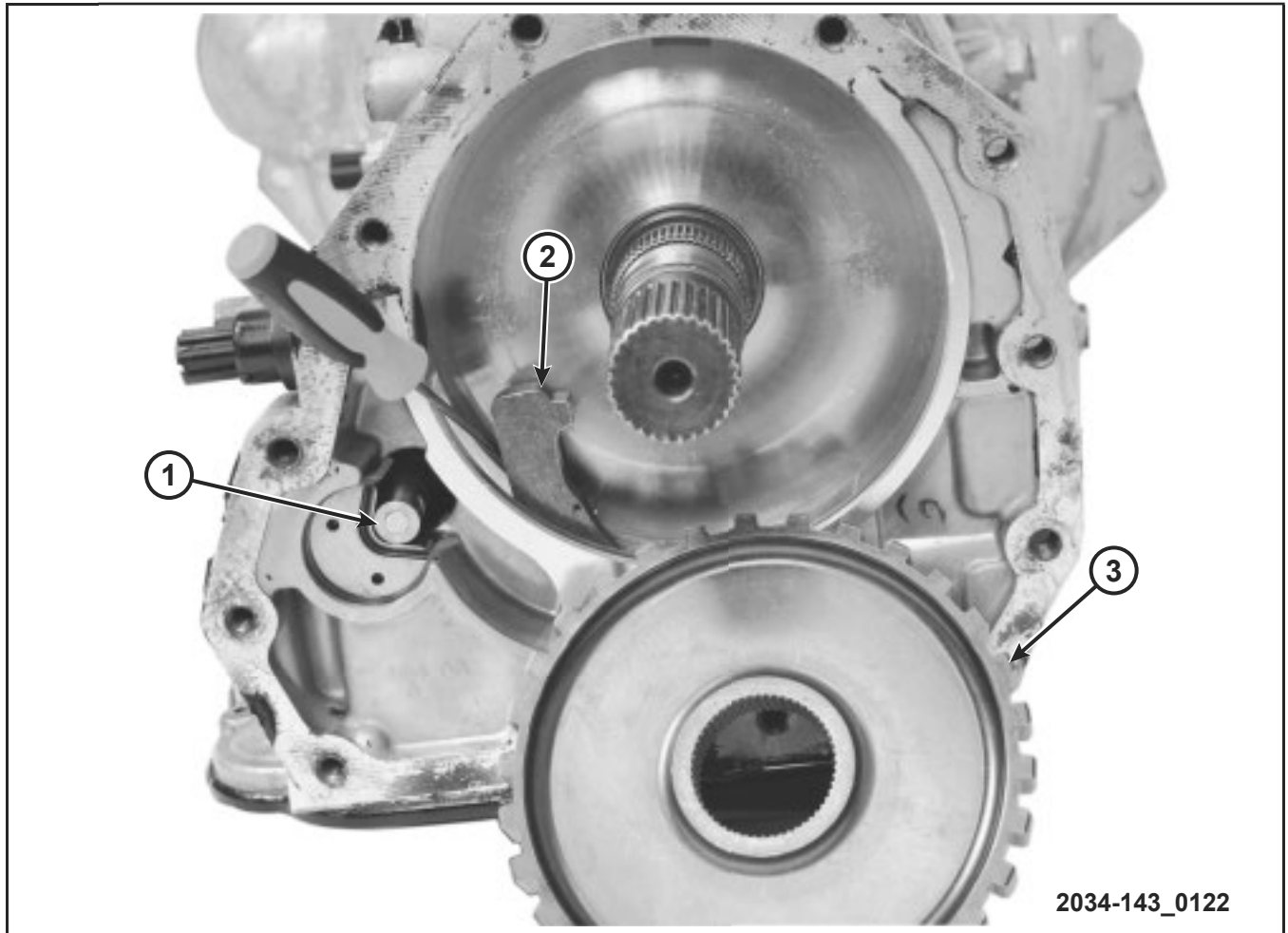

1	Spring-loaded Park Actuator	3	Park Gear
2	Spring-loaded Park Pawl		

Figure 77 Park Lock System (RFE shown)

This transmission uses a spring-loaded actuator rod, connected to the shift linkage, to control the position of the parking pawl. The parking pawl is spring-loaded to pull away from the parking gear. The parking gear is splined to the output shaft. The parking pawl engages the teeth on the parking gear to prevent movement.

Park Lock System

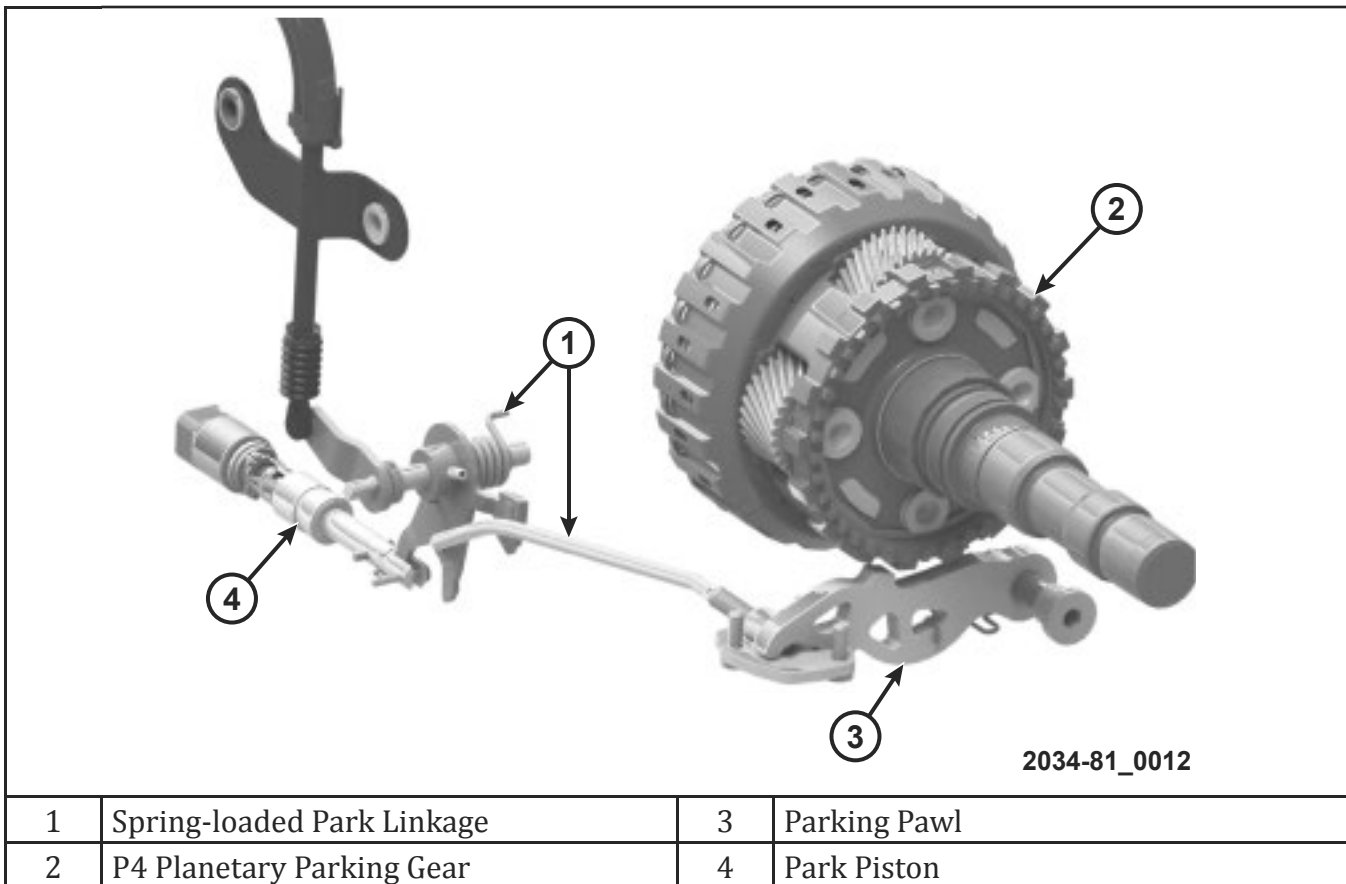

Figure 78 Park Lock System (8-speed shown)

Some of the newer transmissions use a shift-by-wire system, so there is no mechanical connection between the shifter and the transmission. The transmission uses a park lock piston to control the position of the parking pawl. The park linkage inside the transmission is similar to previous designs; however, this linkage is spring-loaded to default into the Park position. The parking pawl engages into the teeth of the parking gear on the P4 carrier to prevent movement.

FINAL DRIVE SYSTEMS

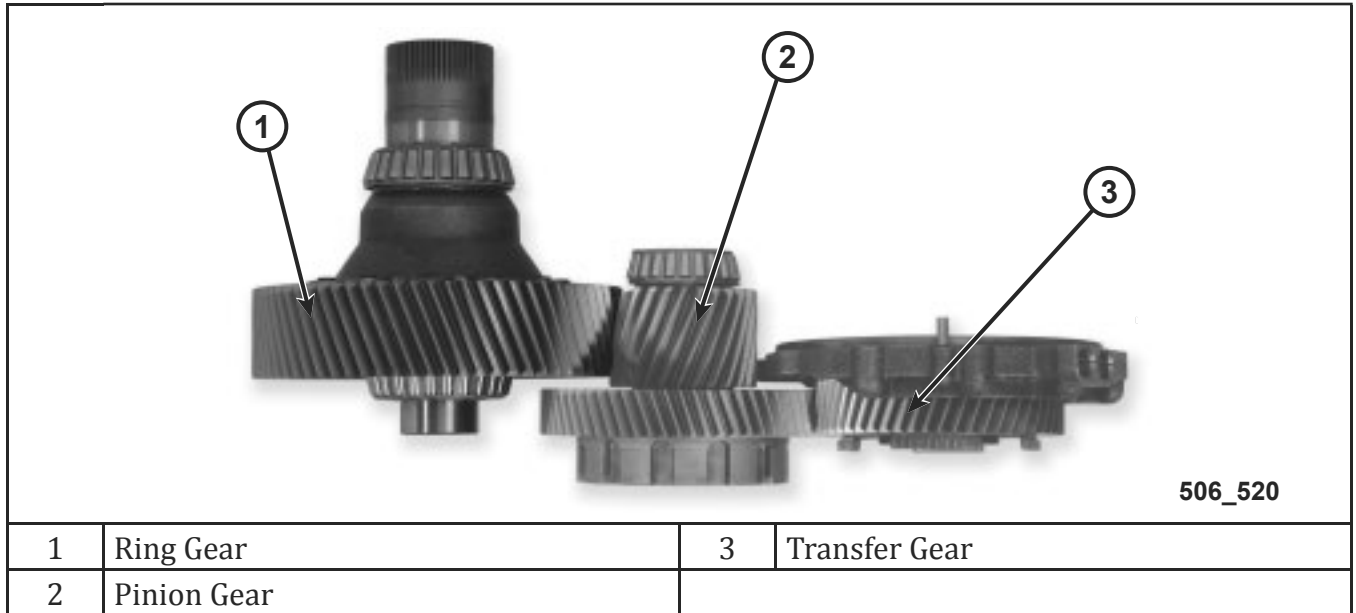

Figure 79 Final Drive System

Transverse-mounted transmissions contain a final drive system to perform the same function as a conventional axle used with a longitudinal transmission. The final drive splits the power between the drive wheels. The final drive includes a transfer gearset to transfer power from the main rotating assembly to the pinion gear. The pinion gear drives the ring gear at the final drive ratio. This is similar to the ring and pinion in a rear axle. The ring gear is mounted to a differential housing that connects to the half shafts. The differential housing contains the differential gears (on most transmissions).

Gearsets

Final Drive Components

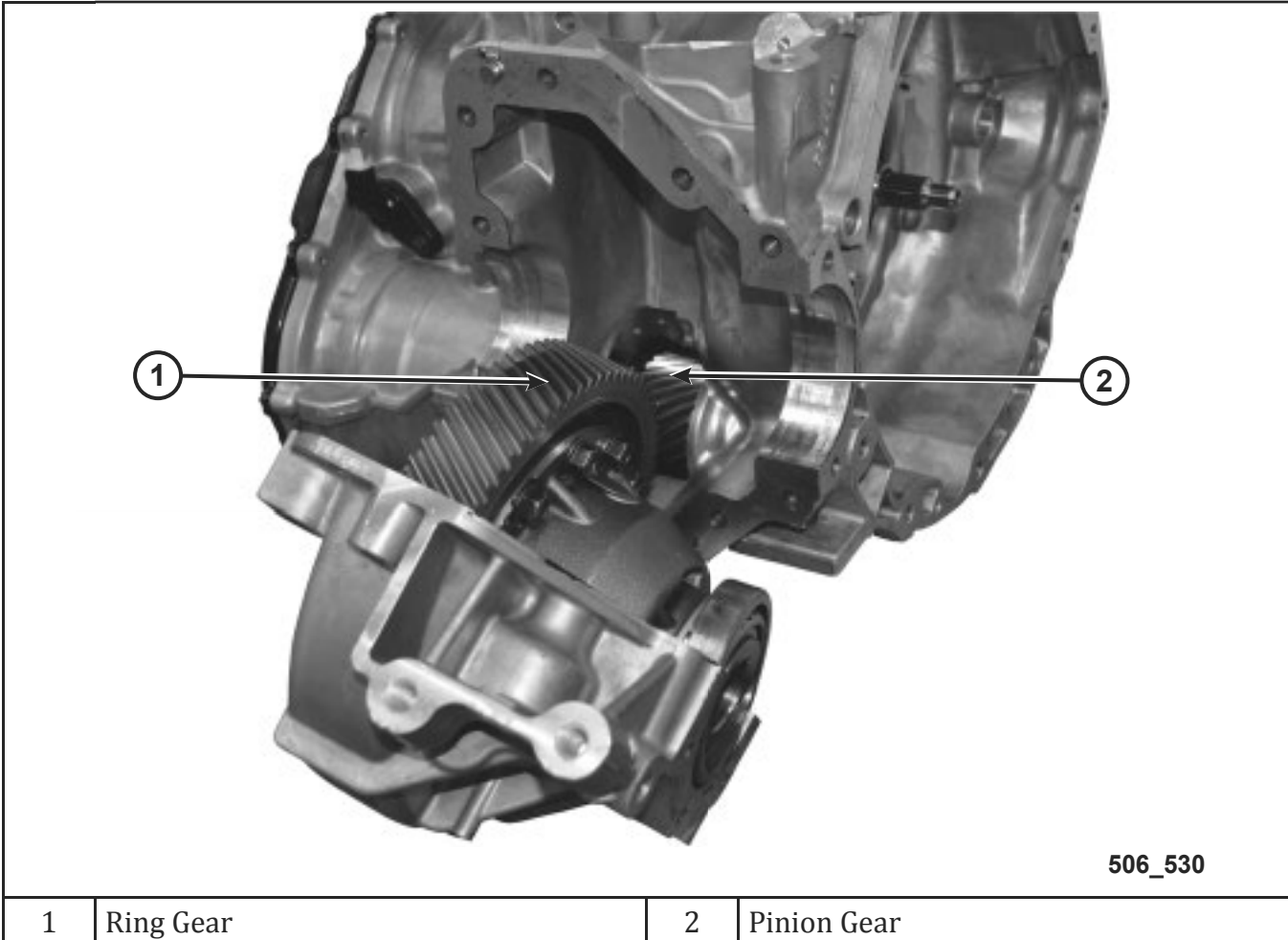

Figure 80 62TE Final Drive

62TE Transfer Gears

The 62TE is an exception to this because the transfer gears are located between the components of the compound gearset. When this transmission is in direct drive, the transfer gears continue to rotate and make noise if they are the source. Because of the location of the transfer gears and the design of the transmission, noisy transfer gears change with the following pattern:

- In 1st and 2nd gear, the noise steadily increases in volume/amplitude with vehicle speed because the main line gearset ratio does not change during the 1-2 shift.
- In 3rd gear, the noise decreases in volume/amplitude due to the ratio change in the main line gearsets. The noise increases with vehicle speed.
- In 4th gear, the noise decreases in volume/amplitude and steadily increases through 5th gear (similar to the 1-2 shift).
- In 5th gear, the noise decreases in volume/amplitude due to the ratio change in the main line gearsets and then increases with vehicle speed.

GEARSET/ROTATING ASSEMBLY NOISE



Figure 81 Typical Geartrain

Because of the complex operation of the typical compound gearsets used in current transmissions, it is very difficult to isolate the root cause of a gearset noise. In many cases, only the general area of the noise can be identified. Based on the symptom, gearset noise can generally be isolated to one of the following:

- Input components
- Output components
- Gearset components.

With transverse-mounted transmissions, the output components also include the final drive.

Input Component Noise

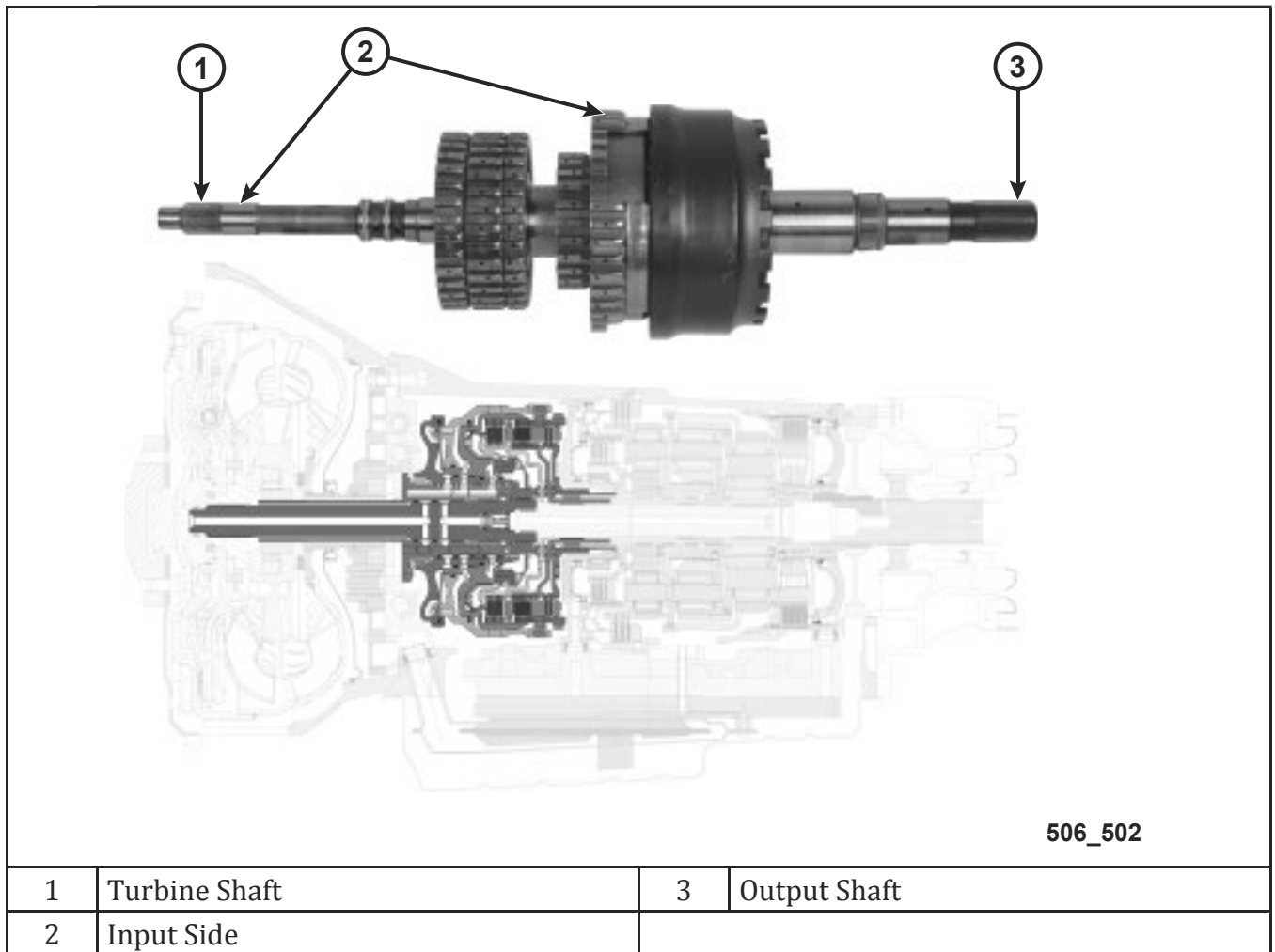

Figure 82 Input Side Noise

The input side of the gearset includes every component that is connected to the turbine shaft. Generally, this includes the rotating clutches and any bushings and bearings that support the turbine shaft. Noise generated by the input side of the gearset occurs any time the turbine is rotating and increases amplitude with engine speed. The noise is most noticeable while moving in Reverse or Drive and may increase under higher loads. The noise will NOT occur when the vehicle is stopped and in gear because the vehicle brakes are holding the turbine shaft from rotating. In Park and Neutral, the rotating input component may generate noise, but because there is no load, it may not be as noticeable.

Output Component Noise

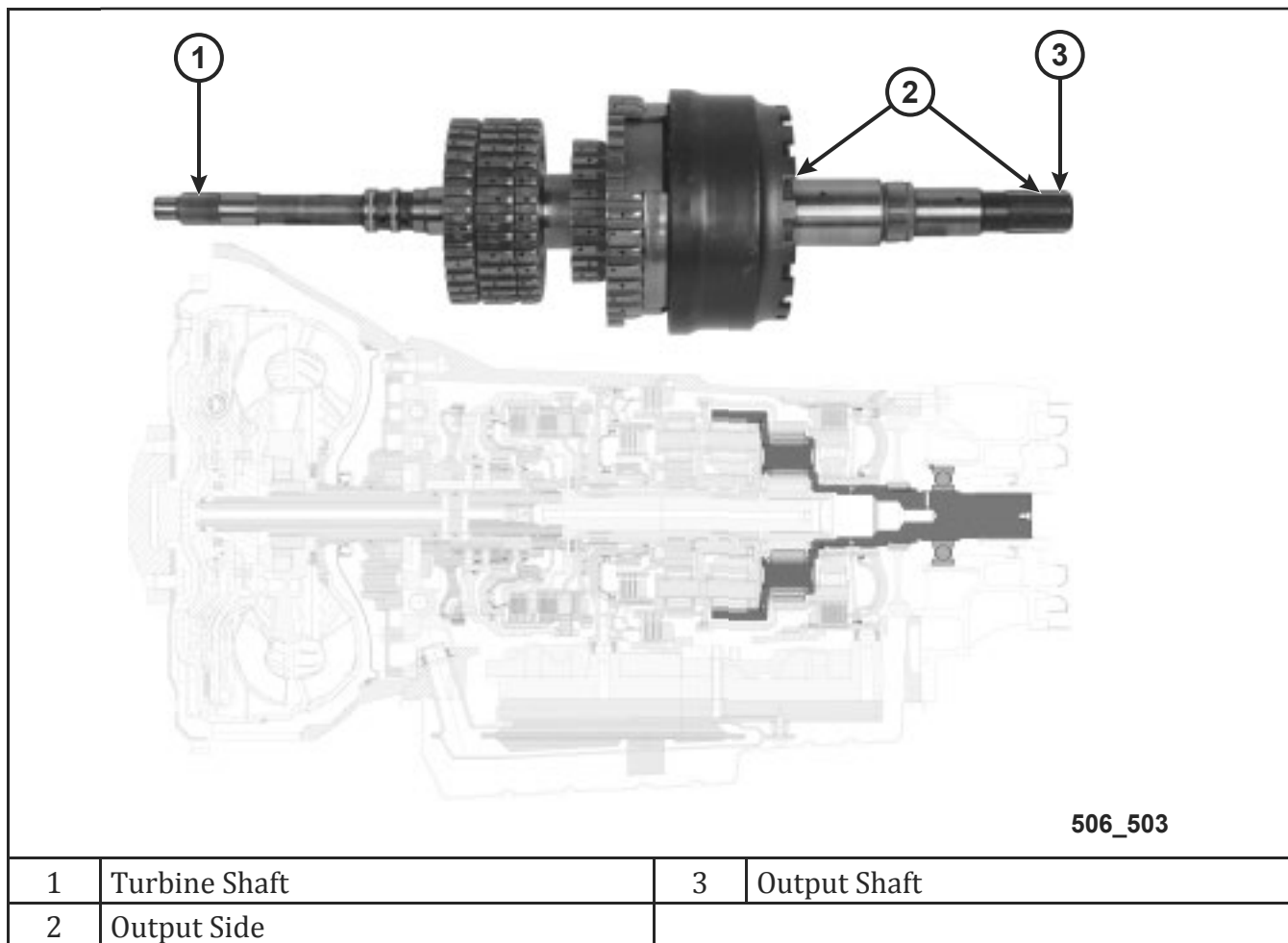
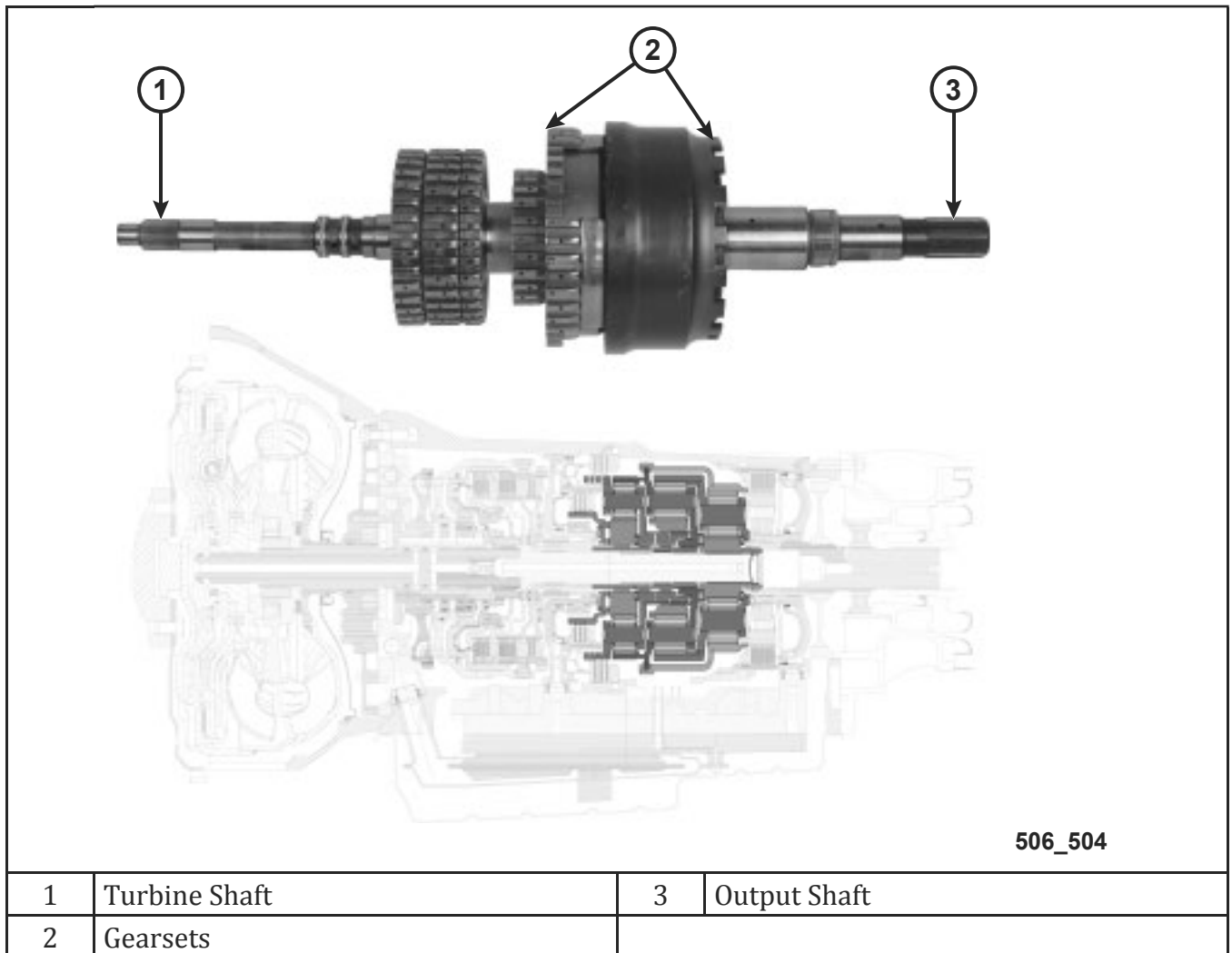

Figure 83 Output Component Noise

Every transmission has single component of the gearset assembly that provides the output for the assembly. On longitudinal transmissions, this component is directly connected to the output shaft of the transmission. On transverse-mounted transmissions, the output of the gearsets is connected to the final drive, typically through transfer gears. The output side of the gearset is supported by bearings and bushings. The rotational speed of the output side of the gearset is always directly proportional to vehicle speed. When the output side of the gearset is the source of the noise, it increases (amplitude) as the vehicle speed increases, and is absent when the vehicle is stopped.

Gearset Noise



1	Turbine Shaft	3	Output Shaft
2	Gearsets		

Figure 84 Gearset Noise

In most cases, it is very difficult to isolate the exact source of noise inside a compound gearset. The components rotate at different speeds (and sometimes different direction) for the various gear ratios. A component with a damaged bushing or gear tooth may generate more noise in one gear ratio than another, and the noise may disappear completely in other gear ratios.

Gearset noise can be isolated by observing what happens to the noise as the transmission shifts to direct drive. In direct drive, all components of the gearset are being driven at the same speed. There are no components within the gearset rotating at different speeds. Because of this operation, any component that was causing noise previously will no longer rotate or make noise. If the noise continues in direct drive, the gearset is not the source of the noise.

Final Drive Noise

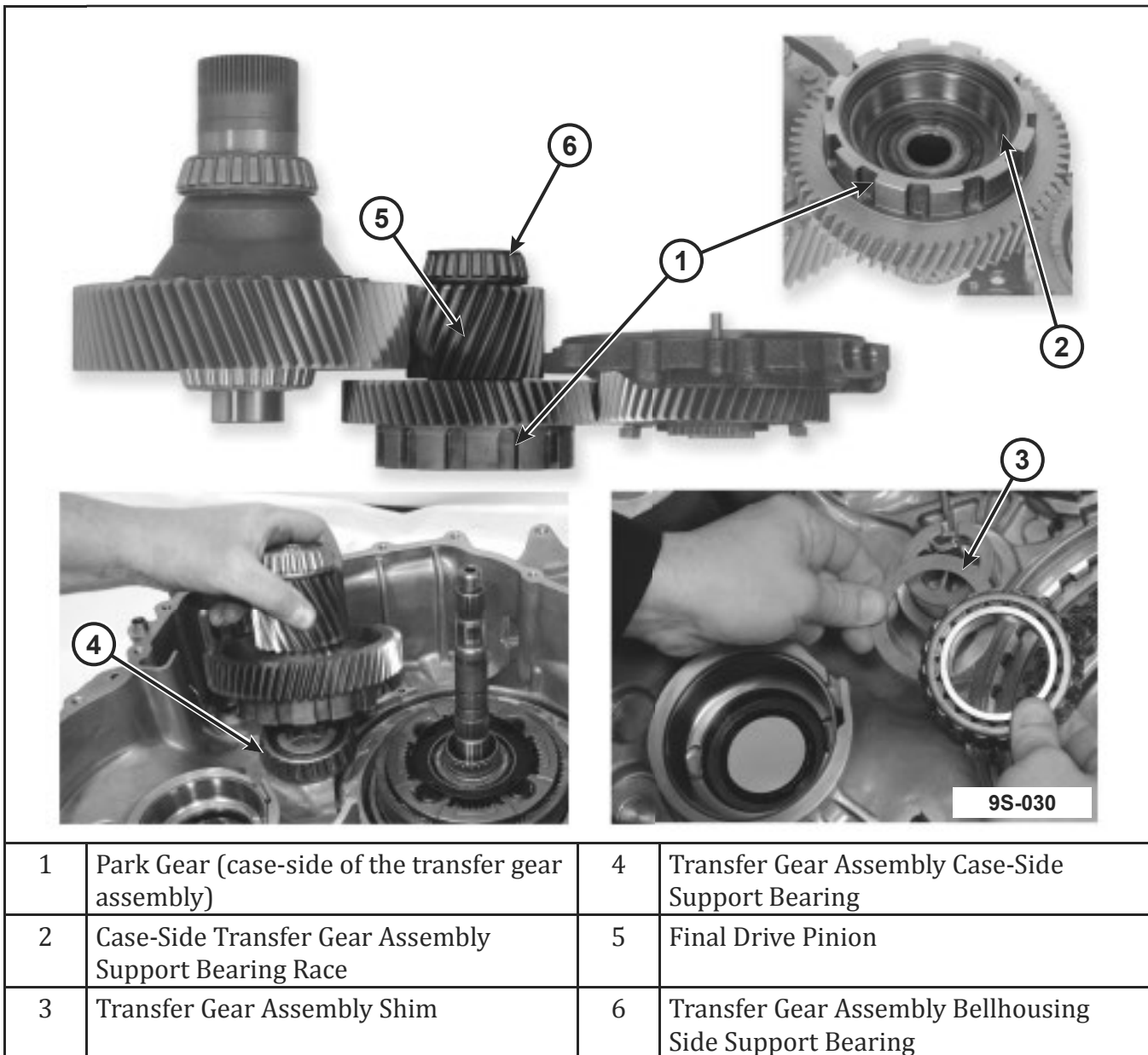

Figure 85 Areas of Possible Noise

In general, the noise generated by final drive components in transverse-mounted transmissions is closely associated with output component noise. The noise is directly proportional to the vehicle speed. It increases in amplitude as the vehicle speed increases. Another noise that can be attributed to the final drive is noise during turns. The majority of final drives have a differential gearset. If the differential is the source of noise, it only generates the noise during turns.

ACTIVITY 11 TRANSMISSION DISASSEMBLY

Instructions: Disassemble the transmission to the bottom of the main section, using the instructions below.

NOTE: This is NOT a service procedure. This procedure was designed for training purposes only. This is a set of instructions to guide you through the in-class activity. Always refer to service information when servicing a vehicle.

1. Remove the six accumulators and cushion springs from the case bores.
 - a. Are all the accumulators interchangeable?

NOTE: Check the accumulator cushion springs for damage. A broken or binding spring can cause a harsh shift concern. Check the accumulator bore for any damage that would cause the accumulator seal to leak. Leaking accumulators can cause a slip or late shift.

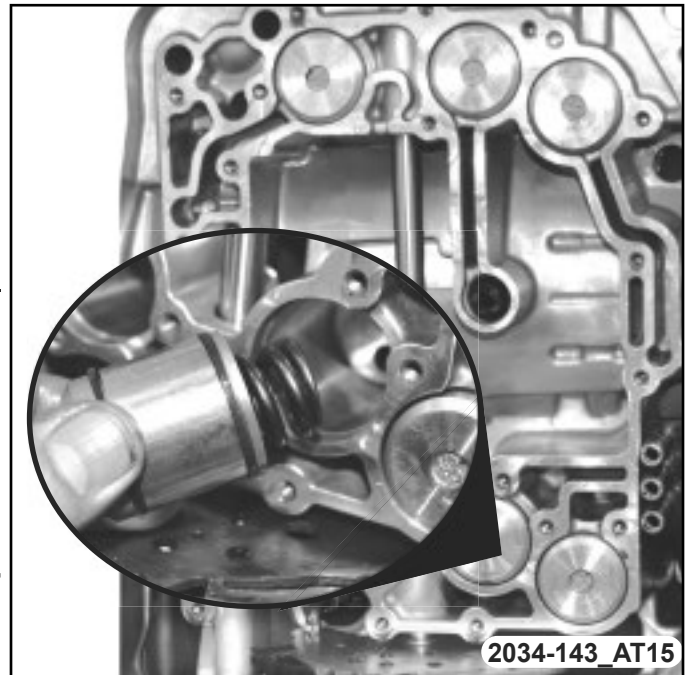

Transmission Disassembly

2. Remove the 2/4 clutch transfer tube seal and set it aside in the parts tray.
 - a. What would be the result of this seal leaking?
-

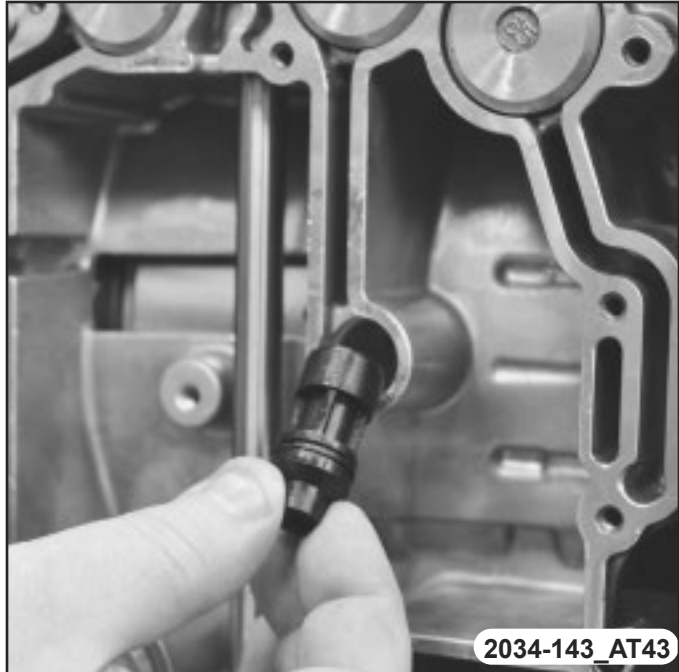

3. Remove the input clutch housing assembly.
 - a. What is the purpose of the tone wheel (1) on the housing?

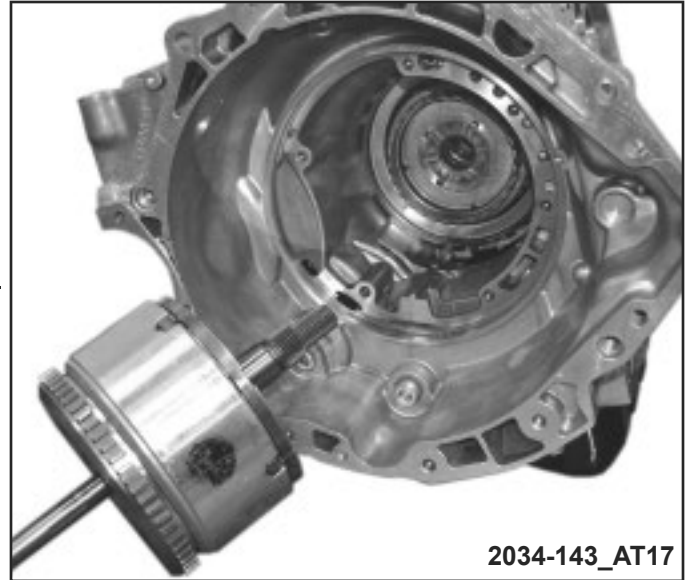

4. Remove the front sun gear assembly (1) and number four thrust washer (2).

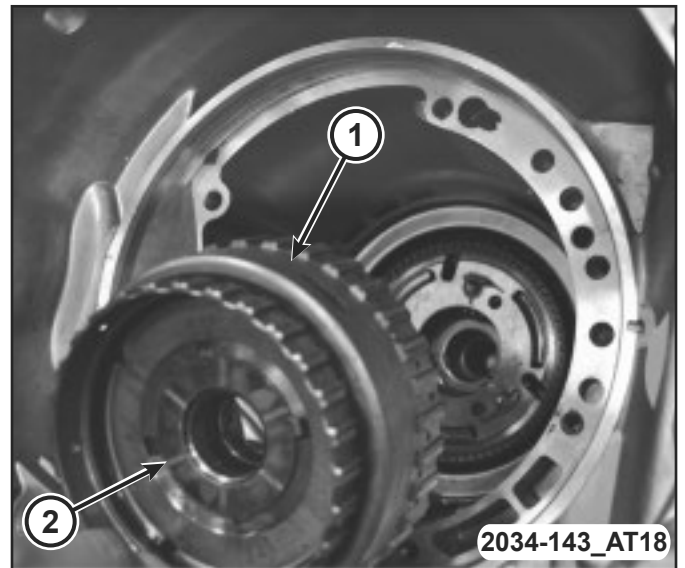

Transmission Disassembly

5. Remove the front carrier/rear annulus assembly.



6. Remove the rear sun gear (1), the number seven thrust bearing (2), and the number six thrust bearing (3).
- a. In which direction is the number six thrust bearing installed?
-
-

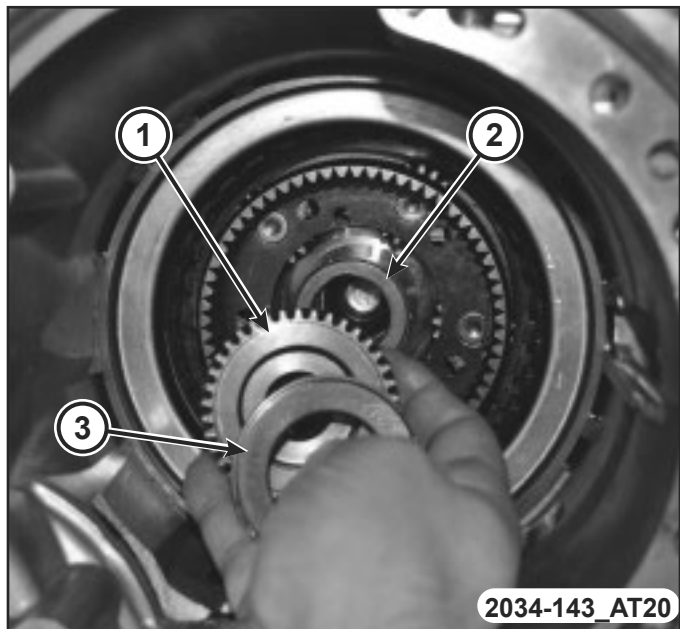

NOTE: The number seven thrust bearing (2) has three anti-reversal tabs and is common with the number five and number two bearing positions. When assembled, the orientation should allow the bearing to seat flat against the rear sun gear (1).

7. Set up the Spring Compressor, 5058A, to compress the 2/4 clutch return spring.

NOTE: Verify that Spring Compressor, 5058A, is centered properly over the 2/4 clutch retainer before compressing the spring. If necessary, fasten the spring compressor bar to the bellhousing flange with any combination of locking pliers and bolts to center the tool properly.

CAUTION: Only compress the 2/4 clutch return spring enough to take the pressure off the snap ring. If the return spring bottoms out, the fingers on the tool will bend.

8. Remove the 2/4 clutch piston snap ring.

9. Remove the 2/4 clutch piston.

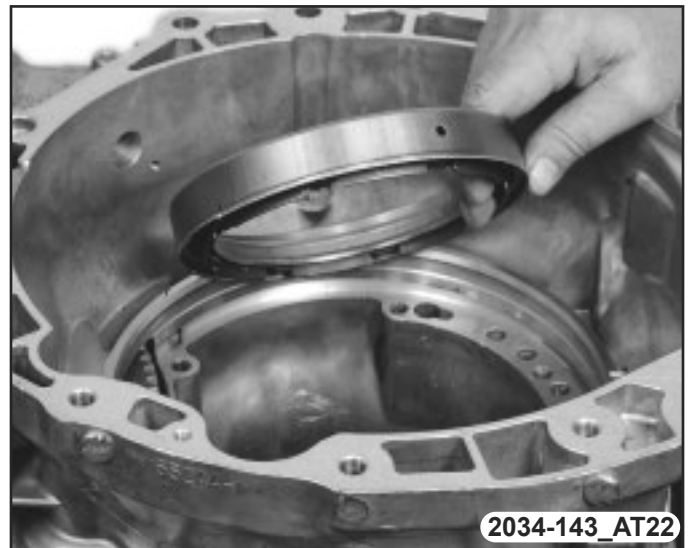
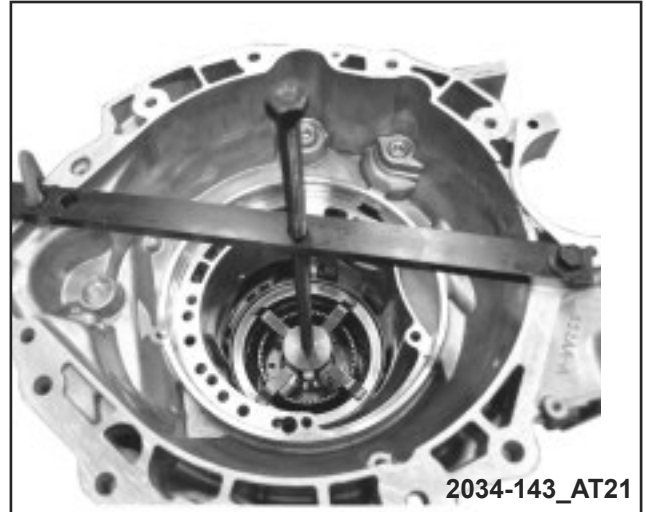

Transmission Disassembly

10. Remove the 2/4 clutch piston return spring.

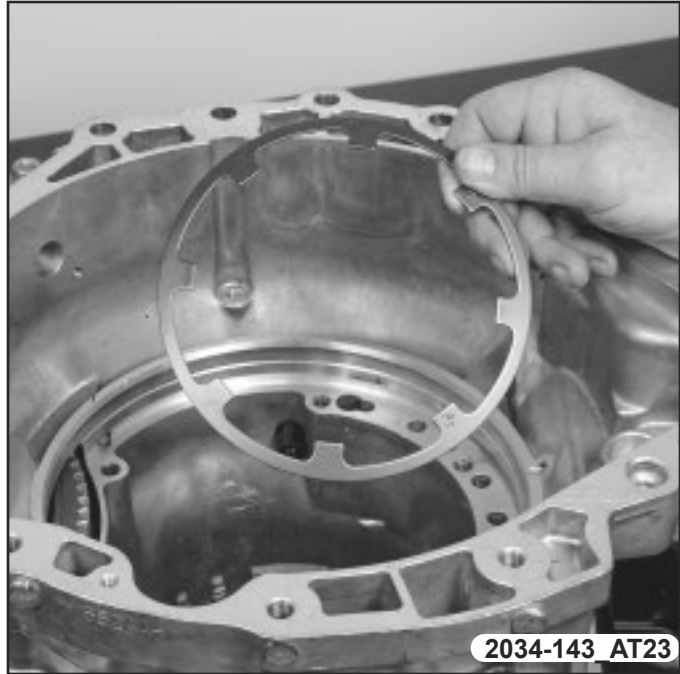

11. Remove the 2/4 clutch pack.
12. Tag the 2/4 clutch pack for proper identification during assembly.
 - a. What color are the 2/4 clutch friction discs?

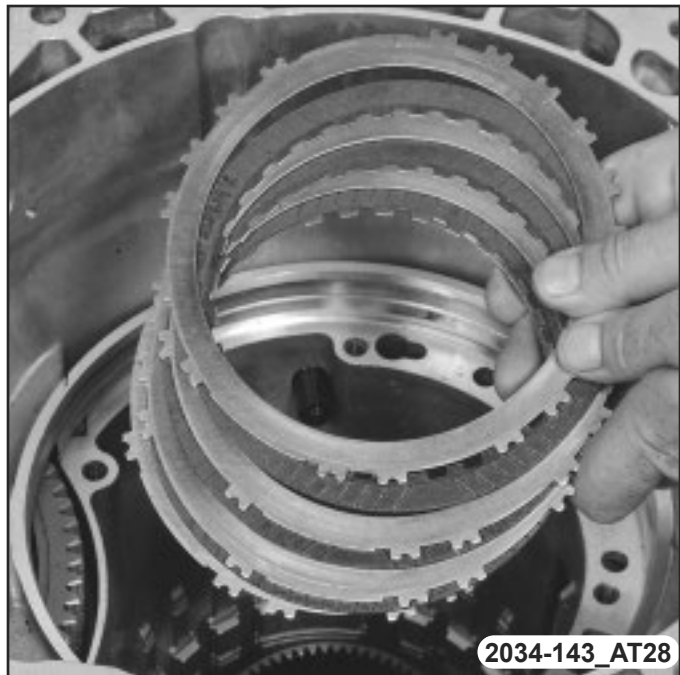

13. Remove the tapered snap ring.
 - a. In what position should the tapered snap ring be installed?
-

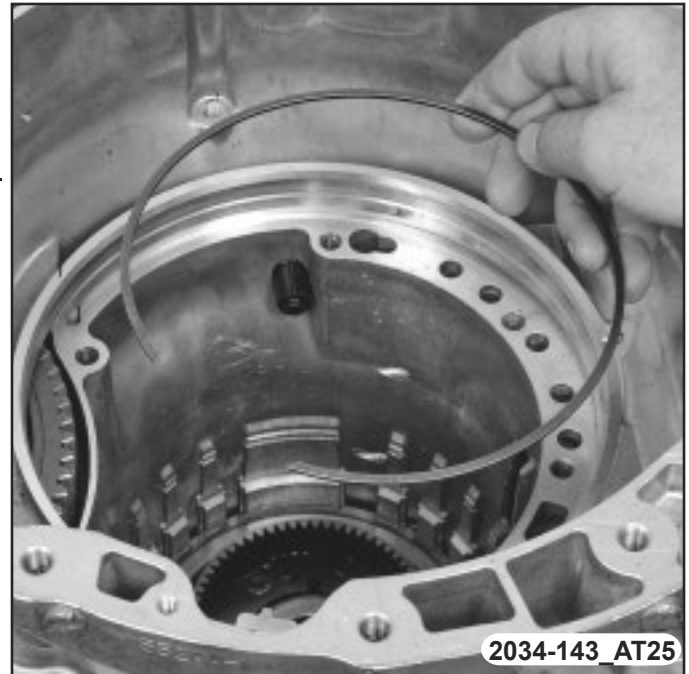

14. Remove the low/reverse clutch reaction plate and the top clutch friction disc.



Transmission Disassembly

15. Remove the low/reverse reaction plate snap ring.
 - a. What is unique about this snap ring?
-



16. Remove the low/reverse clutch pack.
 17. Tag the low/reverse clutch reaction plates for proper assembly.
 - a. What color are the low/reverse clutch friction discs?
-



18. Remove the transfer gear cover bolts and remove the cover.
19. Remove the oil scavenger.

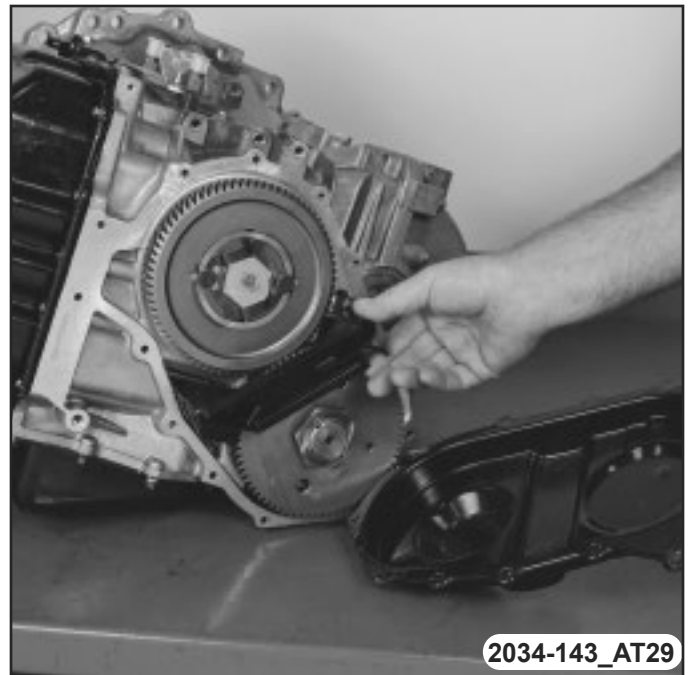

Transmission Disassembly

20. Bend back the locking tabs (2) at the output transfer gear retaining strap (3).
21. Remove the bolts (1) at the output transfer gear retaining strap (3).
22. Remove the output transfer gear retaining strap (3).

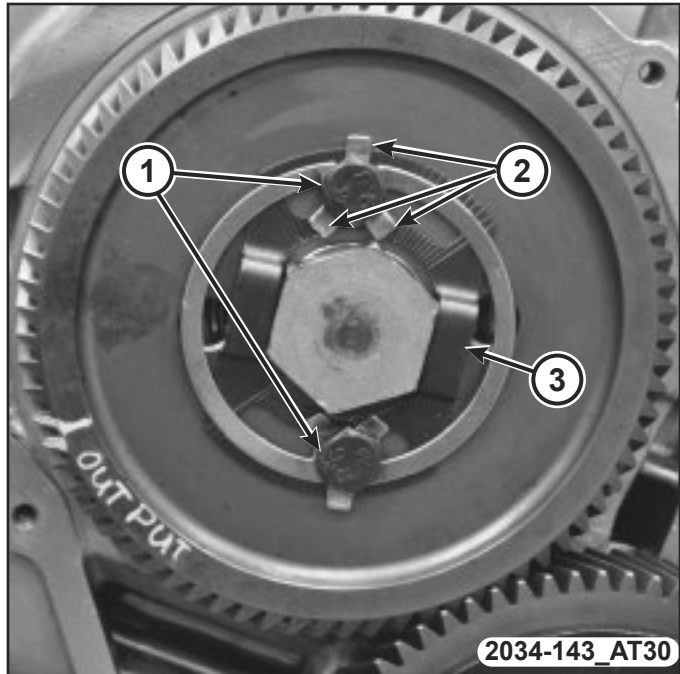

23. Install the Gear Holder, 9739 (2), onto the output transfer gear (3).
24. Remove the output transfer gear bolt (1).

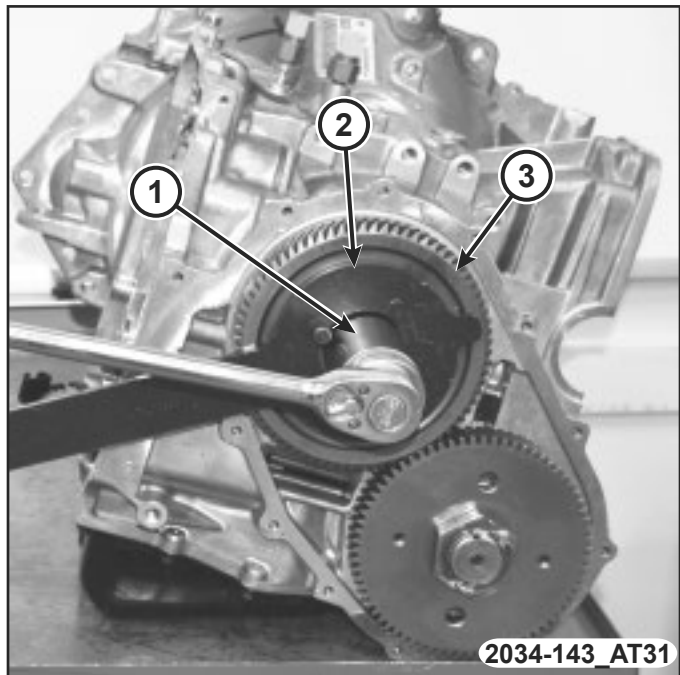

25. Using Gear Puller, L-4407A (1), and Thrust Button, 6055 (2), remove the output shaft transfer gear and the selectable shim.
26. The selectable shim may remain on the rear carrier shaft.



27. Remove the rear carrier assembly and sun gear from the transaxle.



Transmission Disassembly

28. For disassembly of the input housing assembly, use the air check fixture.
29. Remove the reverse clutch snap ring.



30. Using a flat screwdriver, remove the reverse clutch reaction plate.



31. Remove the reverse clutch pack.
32. The reverse clutch pack consists of two friction discs and one separator plate.
33. Tag the clutch pack for assembly.



34. Using a small screwdriver, remove the OD pressure plate flat snap ring.



Transmission Disassembly

35. Remove the OD/reverse pressure plate.
- What direction is this pressure plate facing?
-
-



36. Remove the OD pressure plate waved snap ring from the bottom of the outer groove.
- What is the purpose of the waved snap ring?
-
-



37. Remove the OD clutch pack.
38. The overdrive clutch pack consists of four friction discs and three separator plates.
39. Tag the clutch pack for assembly.



40. Remove the overdrive hub/shaft assembly (2).
41. Tag the thrust plate for assembly (1).

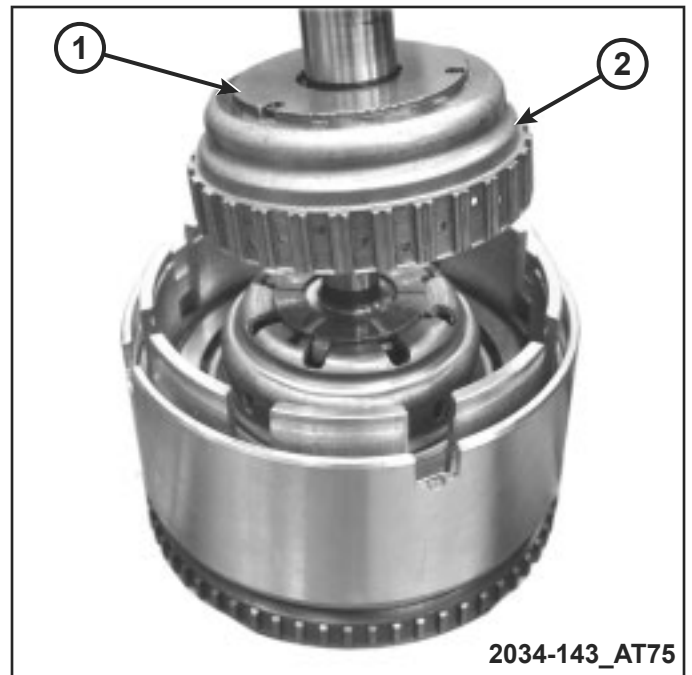

Transmission Disassembly

42. The number two thrust bearing (2) remains installed in the center of the input housing clutch hub (3).
43. Remove the underdrive shaft assembly.
44. Tag all bearings and thrust washers for assembly.

NOTE: The number two thrust bearing is a light press fit into the clutch hub. There are five tabs with dimples that can be pressed in by hand.

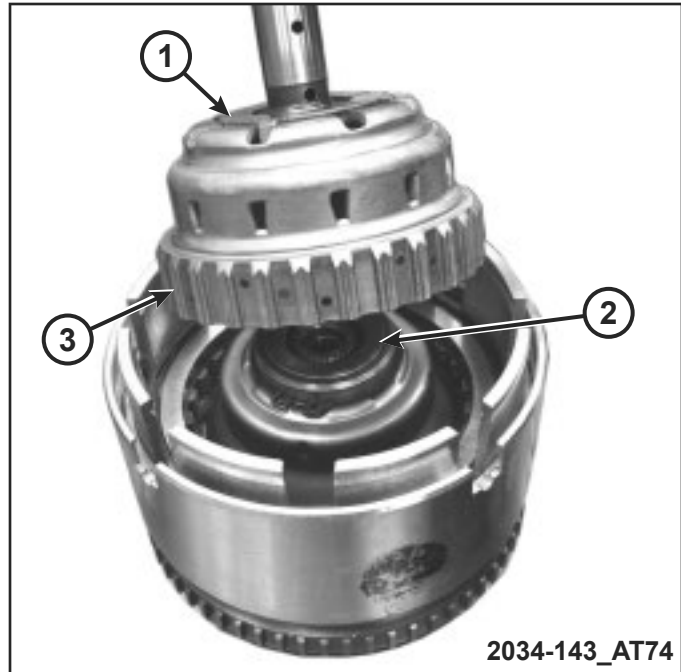

Notes: _____

Notes: _____

DEMONSTRATION 5 CLUTCH APPLICATION CHART

Instructions: In this demonstration, the instructor will ensure that all students understand how to use the clutch application chart for diagnostics. In order to perform this demonstration, we will be diagnosing a 3-4 shift problem where the transmission will not shift to 4th gear. The instructor will help navigate through the questions and provide any required information.

62TE Clutch Application Chart									
Gear	Ratio	Main Line Clutches					Compounder		
		UD	OD	R	2/4	L/R	LC	DC	ORC
1st Gear	4.12:1	X				X	X*		H
2nd Gear	2.84:1	X				X		X	
3rd Gear**	2.28:1	X			X		X*		H
4th Gear (P)	1.57:1	X			X			X	
4th Gear	1.45:1	X	X				X*		H
5th Gear	1:1	X	X					X	
6th Gear	0.68:1		X		X			X	
Reverse	3.21:1			X		X	X		

X = Applied (P) = Prime
 H = Holding X* = Applied During Coast Only
 ** = Default Gear

506_006

1. Where is the clutch application chart located in service information?

2. Using the clutch application chart, which clutches are associated with 4th gear (not 4th prime)?

3. Which clutches are in transition during a normal 3-4 shift?

4. Are either the UD or LC clutches likely part of the concern? Why or why not?

Clutch Application Chart

5. Which clutch is the likely source of the concern?

6. Is the clutch the only possible cause of the concern?

7. Use the components on the bench and service information to identify the clutches and hubs on the cross-section.

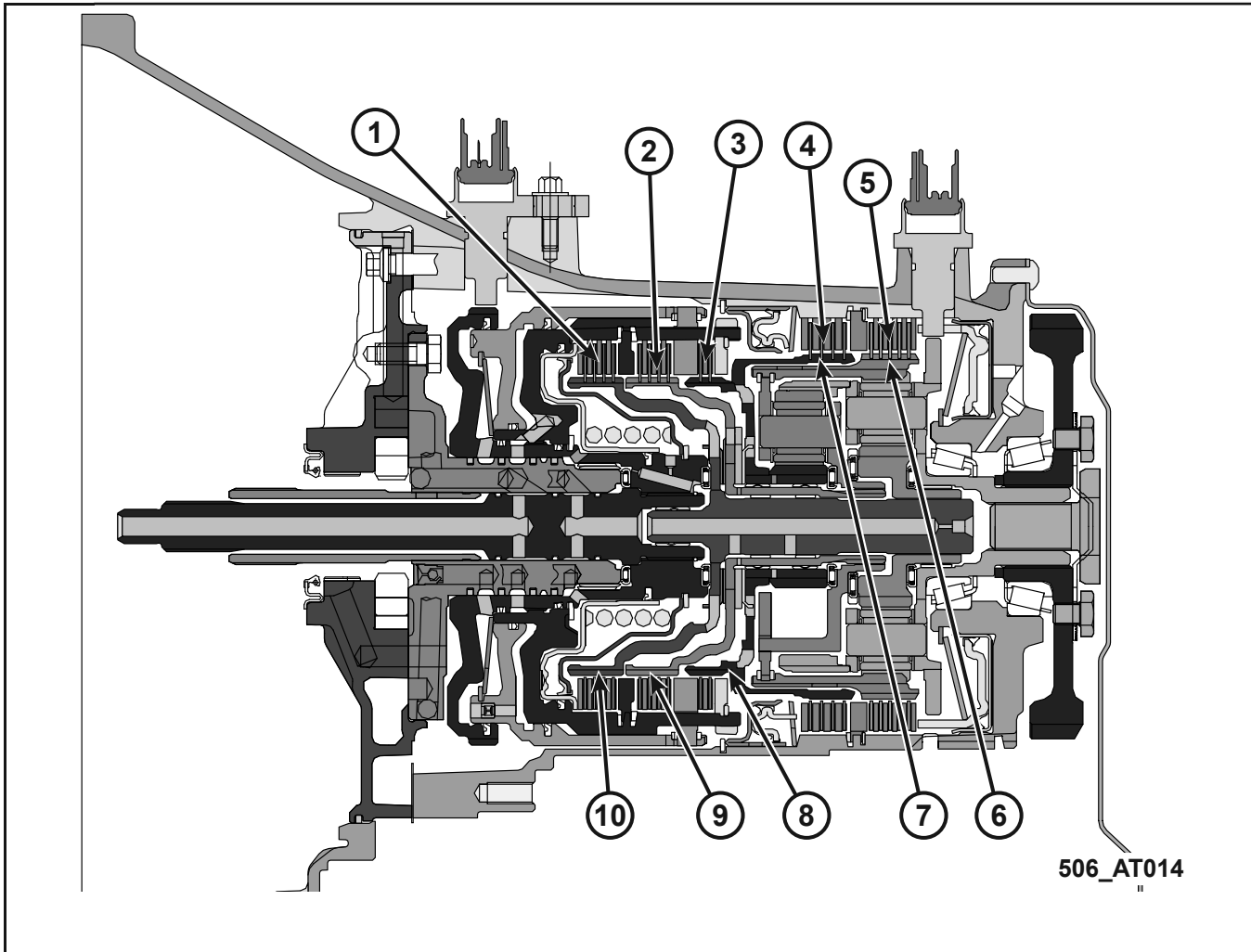

Underdrive Clutch	L/R Clutch Hub (front carrier/rear annulus)
Overdrive Clutch	2-4 Clutch Hub (front sun gear)
Reverse Clutch	Reverse Clutch Hub
2-4 Clutch	Overdrive Clutch Hub
Low/Reverse Clutch	Underdrive Clutch Hub

8. Which numbered components above could result in no shift into 4th gear?

Instructions: The instructor will demonstrate the build-up of the gearset to be used in the activity following this demonstration.



9. The instructor will demonstrate the concern on the gearset showing 3rd gear and then 4th gear powerflow.
10. The instructor will demonstrate and discuss the following symptom terms. Fill in the description as it is discussed:
 - a. Missing gear:

- b. Neutral flare:

- c. Tie up:

- d. Harsh shift:

Clutch Application Chart

e. Soft shift:



ACTIVITY 12 CLUTCH AND GEARSET INTERACTION

TASK ONE: UNDERDRIVE POWERFLOW

Instructions: Using the clutch application chart, answer the following questions.

62TE Clutch Application Chart									
Gear	Ratio	Main Line Clutches					Compounder		
		UD	OD	R	2/4	L/R	LC	DC	ORC
1st Gear	4.12:1	X				X	X*		H
2nd Gear	2.84:1	X				X		X	
3rd Gear**	2.28:1	X			X		X*		H
4th Gear (P)	1.57:1	X			X			X	
4th Gear	1.45:1	X	X				X*		H
5th Gear	1:1	X	X					X	
6th Gear	0.68:1		X		X			X	
Reverse	3.21:1			X		X	X		

X = Applied (P) = Prime
 H = Holding X* = Applied During Coast Only
 ** = Default Gear

506_006

- How can you determine that a gear is underdrive?

- How many forward underdrive gears are there in this transmission?

- Which gears in this transmission are underdrive?

- In underdrive, which has a higher rpm, turbine or output speed?



Clutch and Gearset Interaction

5. Use the flight recording [62TERecording2.xml](#) to answer the following questions.
- a. Move the timeline to 8 seconds in the flight recording. What is the target gear?
-
- b. Is this gear overdrive, underdrive, or direct?
-
- c. Is the turbine speed or output speed higher?
-
- d. Does this match what is normal for an underdrive gear?
-
- e. Now divide the turbine speed rpm by the output speed rpm. Does the result match the gear ratio?
-



6. Follow the setup instructions to assemble your planetary gearsets.
7. Gather these parts and set them in an open area on the workbench.

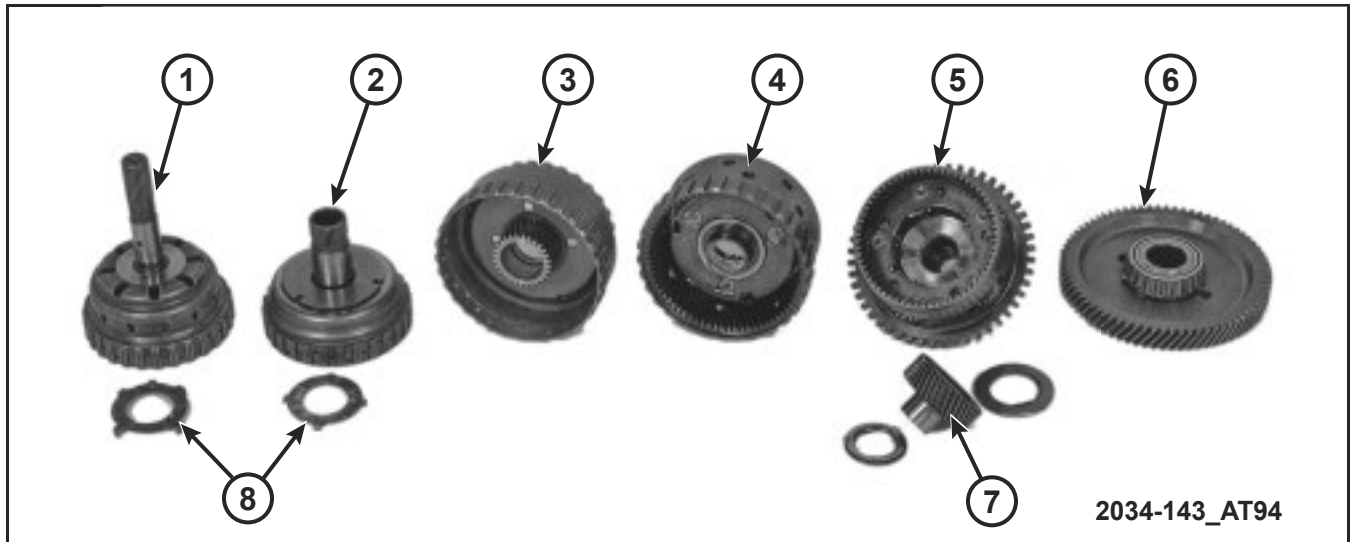

1	Underdrive Hub	5	Rear Carrier/Front Annulus
2	Overdrive Hub	6	Transfer Gear
3	Front Sun Gear	7	Rear Sun Gear
4	Front Carrier/Rear Annulus	8	Thrust Washers

8. Place the output transfer gear on a smooth surface to allow it to rotate freely during the powerflow test.
9. Place the output carrier assembly onto the transfer gear.



Clutch and Gearset Interaction

10. Install the rear sun gear and needle bearings.



11. Install the rear front carrier/rear annulus assembly onto the output carrier and sun gear.
12. Rotate the front carrier to align the planetary gears.



13. Install the front sun gear shell onto the front carrier.



14. Install the overdrive hub thrust washer onto the front sun gear shell.



Clutch and Gearset Interaction

15. Install the overdrive hub shaft into the front carrier/rear annulus.



16. Install the underdrive hub shaft into the rear sun gear.



17. Use a paint marker to mark a line on each of the members of the gear train (1).

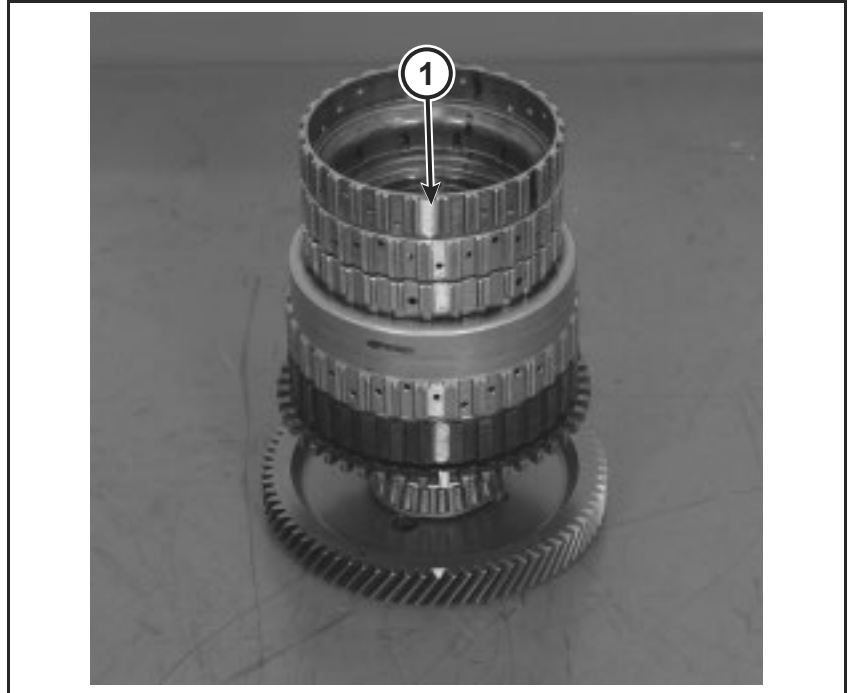

18. Simulate 1st gear with the gearset.
19. How does the input rotation compare to the output rotation (speed)?
-
20. Are any components of the gearset held to a stop?
-



Clutch and Gearset Interaction

21. Identify the clutches and hubs on the cross-section that are related to 1st gear. Not all numbers will be used.

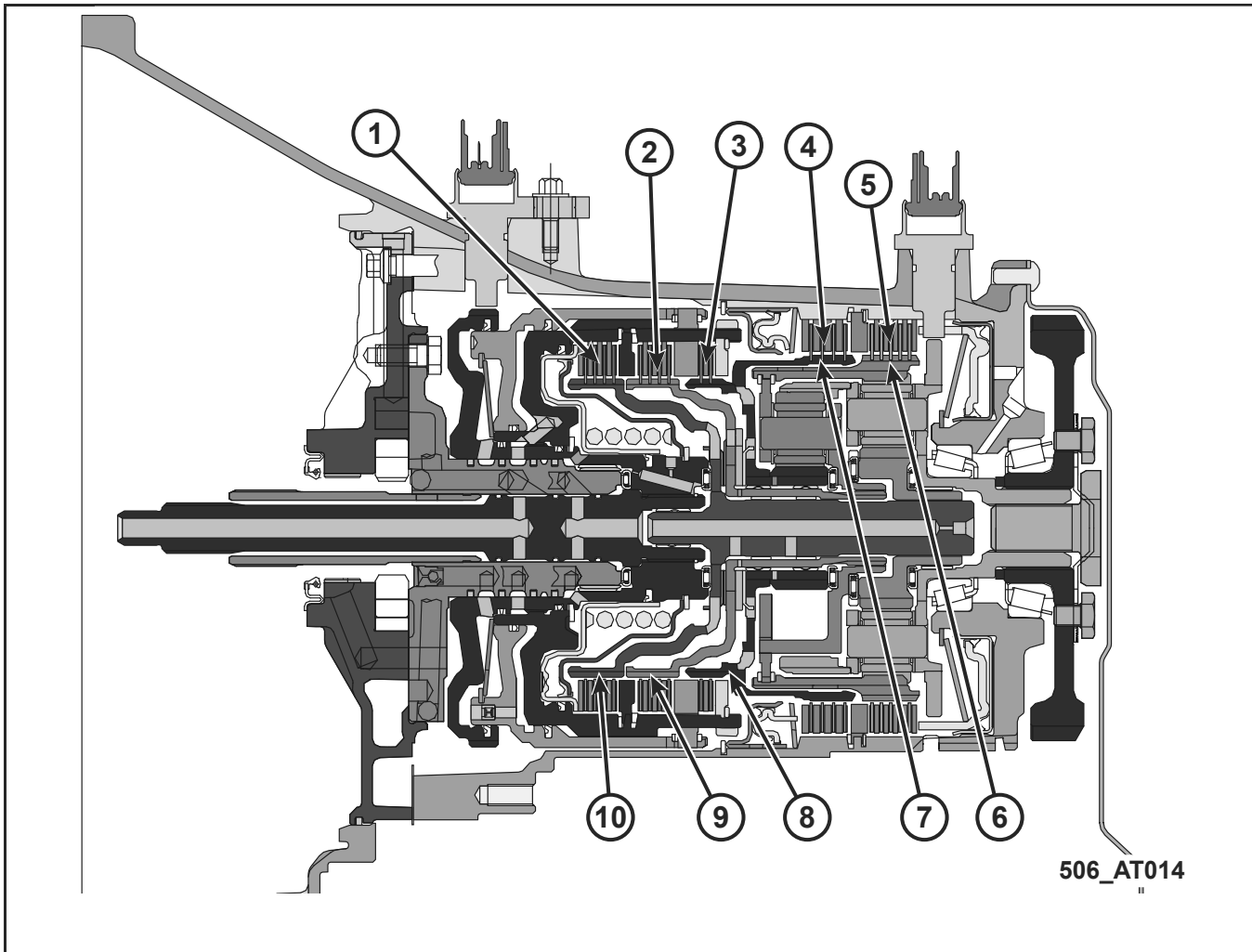

	Underdrive Clutch		L/R Clutch Hub (front carrier/rear annulus)
	Overdrive Clutch		2-4 Clutch Hub (front sun gear)
	Reverse Clutch		Reverse Clutch Hub
	2-4 Clutch		Overdrive Clutch Hub
	Low/Reverse Clutch		Underdrive Clutch Hub



TASK TWO: DIRECT DRIVE POWERFLOW

Instructions: Using the clutch application chart, answer the following questions.

62TE Clutch Application Chart									
Gear	Ratio	Main Line Clutches					Compounder		
		UD	OD	R	2/4	L/R	LC	DC	ORC
1st Gear	4.12:1	X				X	X*		H
2nd Gear	2.84:1	X				X		X	
3rd Gear**	2.28:1	X			X		X*		H
4th Gear (P)	1.57:1	X			X			X	
4th Gear	1.45:1	X	X				X*		H
5th Gear	1:1	X	X					X	
6th Gear	0.68:1		X		X			X	
Reverse	3.21:1			X		X	X		

X = Applied
H = Holding
** = Default Gear

(P) = Prime
X* = Applied During Coast Only

506_006

1. How can you determine that a gear is direct drive?

2. How many forward direct drive gears are there in this transmission?

3. Which gears in this transmission are direct drive?

4. In direct drive, which has a higher rpm, turbine or output speed?

Clutch and Gearset Interaction

5. Use the flight recording [62TERecording2.xml](#) to answer the following questions.
- a. Move the timeline to 28 seconds. Is the turbine speed or output speed higher in direct drive?
-
- b. Does this match what is normal for direct drive?
-
- c. Now divide the turbine speed rpm by the output speed rpm. Does the result match the gear ratio?
-

Instructions: Use the Task One setup with the gearsets to answer the following questions.

6. Simulate direct drive with the gearset.
7. How does the input rotation compare to the output rotation?
-
8. Are any components of the gearset held to a stop?
-

9. Identify the clutches and hubs on the cross-section that are related to 5th gear. Not all numbers will be used.

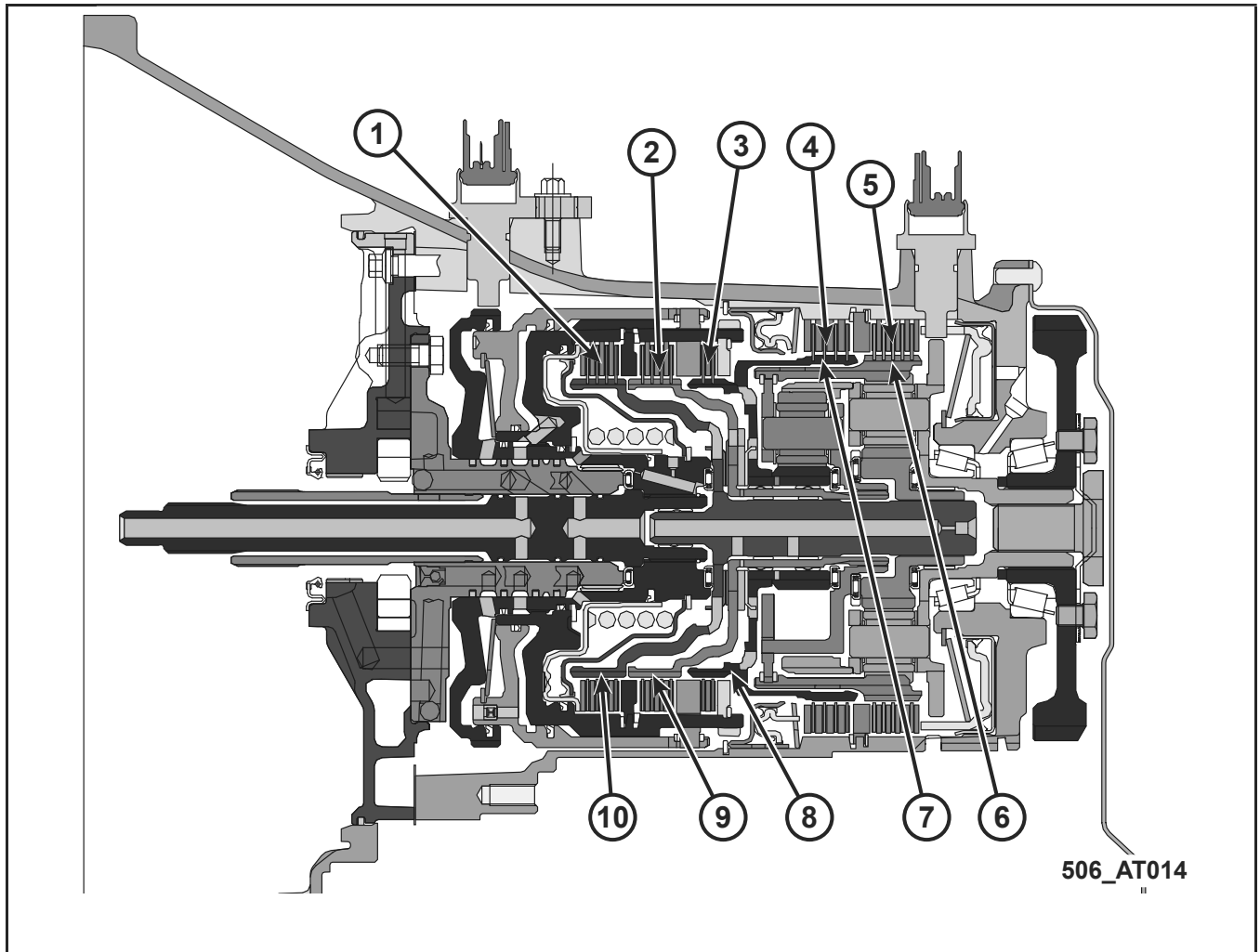

	Underdrive Clutch		L/R Clutch Hub (front carrier/rear annulus)
	Overdrive Clutch		2-4 Clutch Hub (front sun gear)
	Reverse Clutch		Reverse Clutch Hub
	2-4 Clutch		Overdrive Clutch Hub
	Low/Reverse Clutch		Underdrive Clutch Hub



Clutch and Gearset Interaction

TASK THREE: OVERDRIVE POWERFLOW

Instructions: Using the clutch application chart, answer the following questions.

62TE Clutch Application Chart									
Gear	Ratio	Main Line Clutches					Compounder		
		UD	OD	R	2/4	L/R	LC	DC	ORC
1st Gear	4.12:1	X				X	X*		H
2nd Gear	2.84:1	X				X		X	
3rd Gear**	2.28:1	X			X		X*		H
4th Gear (P)	1.57:1	X			X			X	
4th Gear	1.45:1	X	X				X*		H
5th Gear	1:1	X	X					X	
6th Gear	0.68:1		X		X			X	
Reverse	3.21:1			X		X	X		

X = Applied (P) = Prime
 H = Holding X* = Applied During Coast Only
 ** = Default Gear

506_006

- How can you determine that a gear is overdrive?

- How many forward overdrive gears are there in this transmission?

- Which gears in this transmission are overdrive?

- In overdrive, which has a higher rpm, turbine or output speed?

5. Use the flight recording [62TERecording2.xml](#) to answer the following questions.
- a. Move the flight recording timeline to 40 seconds. Is the turbine speed or output speed higher in the overdrive gear that you selected?
-
- b. Does this match what is normal for overdrive?
-
- c. Now divide the turbine speed rpm by the output speed rpm. Does the result match the gear ratio?
-

Instructions: Use the Task One setup with the gearsets to answer the following questions.

6. Simulate overdrive with the gearset.
7. How does the input rotation compare to the output rotation?
-
8. Are any components of the gearset held to a stop?
-

Clutch and Gearset Interaction

9. Identify the clutches and hubs on the cross-section that are related to 6th gear. Not all numbers will be used.

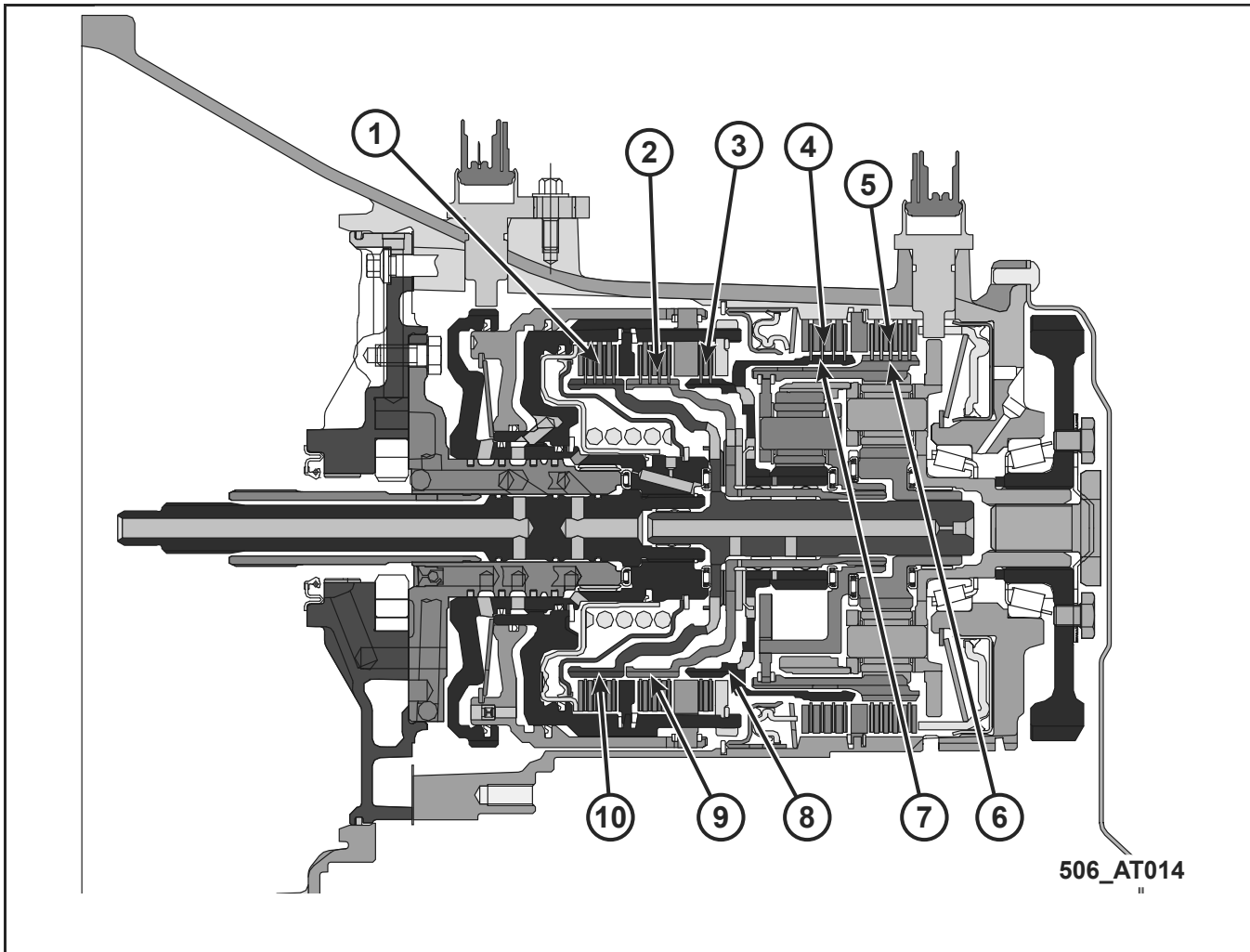

	Underdrive Clutch		L/R Clutch Hub (front carrier/rear annulus)
	Overdrive Clutch		2-4 Clutch Hub (front sun gear)
	Reverse Clutch		Reverse Clutch Hub
	2-4 Clutch		Overdrive Clutch Hub
	Low/Reverse Clutch		Underdrive Clutch Hub



Notes: _____

Notes:

ACTIVITY 13 GEARSET MECHANICAL DIAGNOSIS

Instructions: A vehicle equipped with a 62TE transmission will not upshift to 4th gear. The transmission attempts the upshift, but it results in a slight neutral flare and then the transmission shifts back to 3rd gear and stays there. Answer the following questions.

NOTE: Activity 12 should have prepared you for this activity by giving you exposure to the components of the gearsets and how they interact with the clutches.

62TE Clutch Application Chart									
Gear	Ratio	Main Line Clutches					Compounder		
		UD	OD	R	2/4	L/R	LC	DC	ORC
1st Gear	4.12:1	X				X	X*		H
2nd Gear	2.84:1	X				X		X	
3rd Gear**	2.28:1	X			X		X*		H
4th Gear (P)	1.57:1	X			X			X	
4th Gear	1.45:1	X	X				X*		H
5th Gear	1:1	X	X					X	
6th Gear	0.68:1		X		X			X	
Reverse	3.21:1			X		X	X		
X = Applied (P) = Prime H = Holding X* = Applied During Coast Only ** = Default Gear									

506_006

1. Which clutch is associated with this concern?

2. Which gearsets and hubs are associated with the clutch that may be causing the concern?

3. Which geartrain components could cause no upshift to 4th gear? Identify the components and look for areas that could fail and cause the concern on your bench.

Notes: _____

ACTIVITY 14 GEARSET HYDRAULIC/LUBRICATION DIAGNOSIS

Instructions: This scenario is a follow up to the previous activity. This scenario explores the hydraulic side of the concern. A vehicle equipped with a 62TE transmission will not upshift to 4th gear. The transmission attempts the upshift, but it results in a slight neutral flare and then the transmission shifts back to 3rd gear and stays there. Answer the following questions.

62TE Clutch Application Chart									
Gear	Ratio	Main Line Clutches					Compounder		
		UD	OD	R	2/4	L/R	LC	DC	ORC
1st Gear	4.12:1	X				X	X*		H
2nd Gear	2.84:1	X				X		X	
3rd Gear**	2.28:1	X			X		X*		H
4th Gear (P)	1.57:1	X			X			X	
4th Gear	1.45:1	X	X				X*		H
5th Gear	1:1	X	X					X	
6th Gear	0.68:1		X		X			X	
Reverse	3.21:1			X		X	X		

X = Applied (P) = Prime
 H = Holding X* = Applied During Coast Only
 ** = Default Gear

506_006

1. Which clutch is associated with this concern?

2. If the clutch plates are glazed or severely damaged, could this cause the symptom?

3. What hydraulic fluid issue could cause this type of damage?

4. How is this associated with gearset operation?

5. How is lubrication provided to the gearsets?

Gearset Hydraulic/Lubrication Diagnosis

6. Besides lubrication, what are the various functions of lubrication fluid?



7. Identify the passages associated with this problem on both the photo below and the physical components shown in the cross-section graphic.

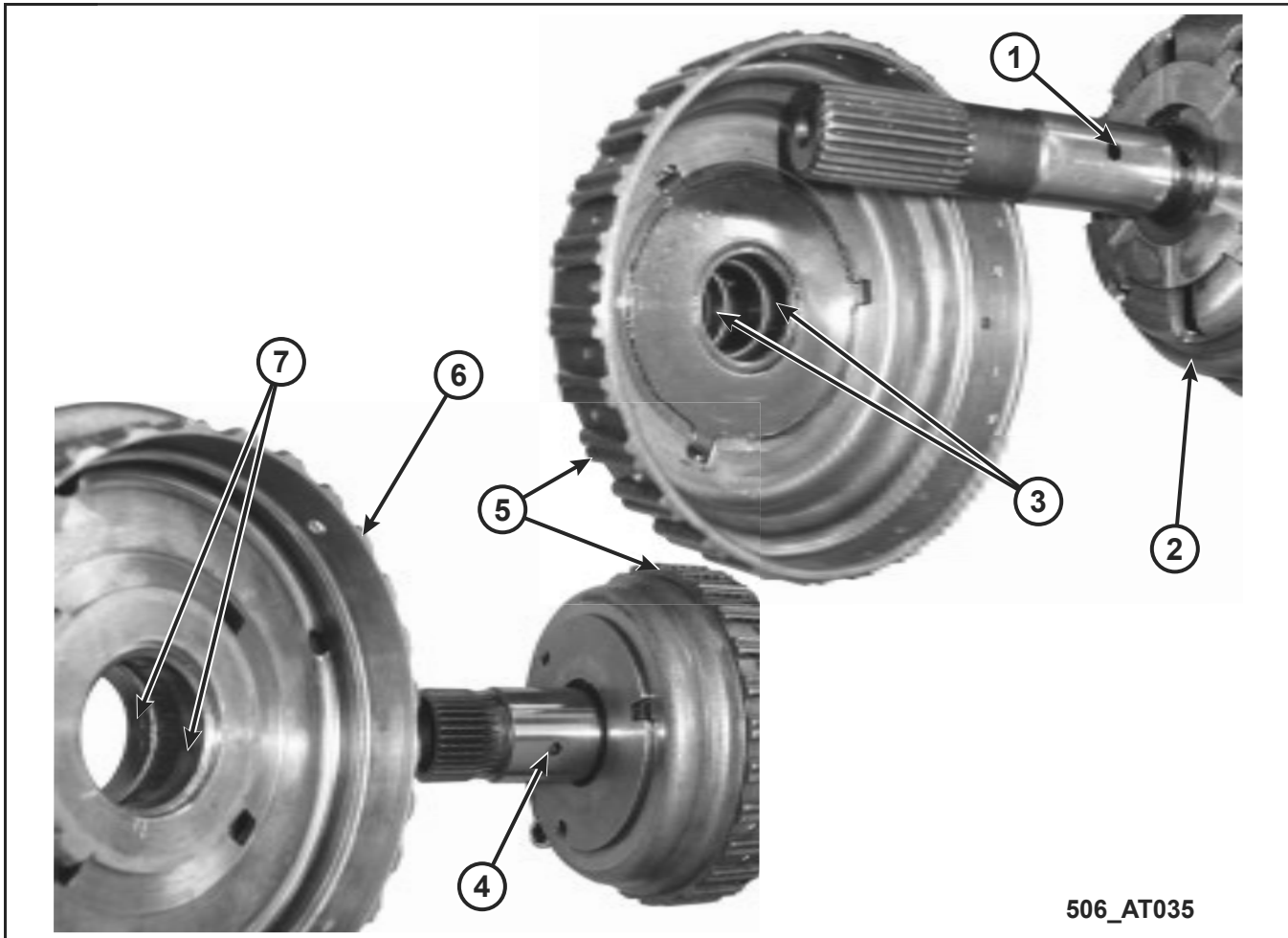

	Reverse Hub Lube Port		Overdrive Hub
	Reverse Hub Bushing		Reverse Hub
	Overdrive Hub Bushing		Underdrive Hub
	Overdrive Hub Lube Port		

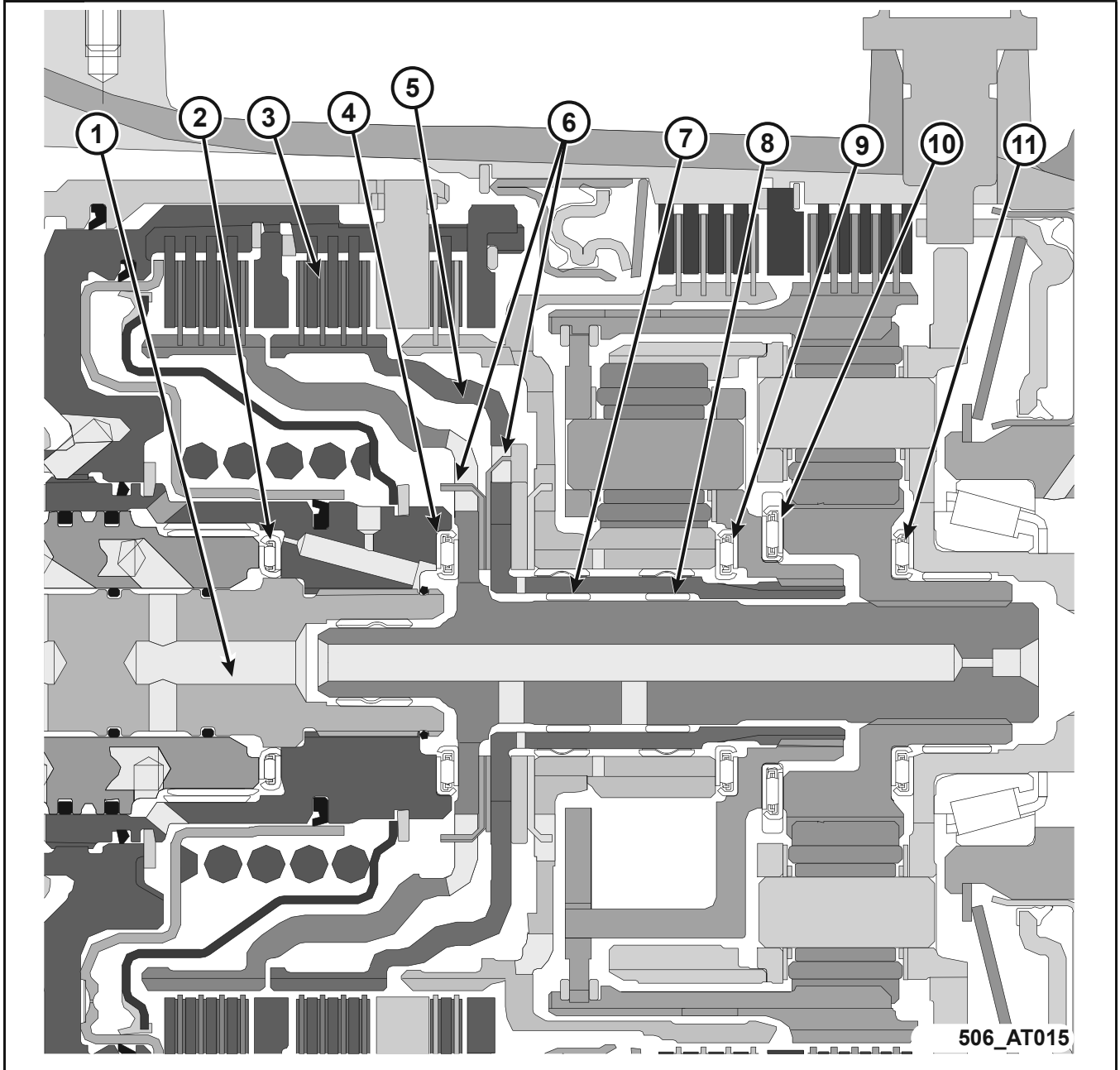

506_AT015

	Lubrication Main Feed		Support Bushings
	Thrust Bearings		Support Bushings
	Thrust Bearings		Overdrive Clutch
	Thrust Bearings		Thrust Bearings
	Overdrive Hub		Thrust Bearings
	Thrust Washers Between Overdrive and Reverse Hub		

Gearset Hydraulic/Lubrication Diagnosis

Instructions: Answer the following question about gearset lubrication flow paths.

8. If one gearset is affected by lack of lubrication, which passages need inspection?

9. If all gearsets are affected by lack of lubrication, which passages need inspection?

10. What would be the symptom if an oil dam or slinger was left out of a transmission during service?



ACTIVITY 15 GEARSET NOISE DIAGNOSIS

Instructions: Answer the following questions on gearset noise.

1. In general, is gearset noise related to changes in engine speed, vehicle speed, or gear ratio?

2. In general, when does gearset noise change?

3. Indicate in which gear ranges gearset noise is typically present. Circle/check mark all that apply.

<input type="checkbox"/>	Park	<input type="checkbox"/>	Neutral
<input type="checkbox"/>	Reverse	<input type="checkbox"/>	Drive

4. Does brake application affect gearset noise?



Gearset Noise Diagnosis

Input Support

Instructions: Place an X next to the items in the list below that support the input side of the gearset and always rotate at turbine speed in this 68RFE transmission.

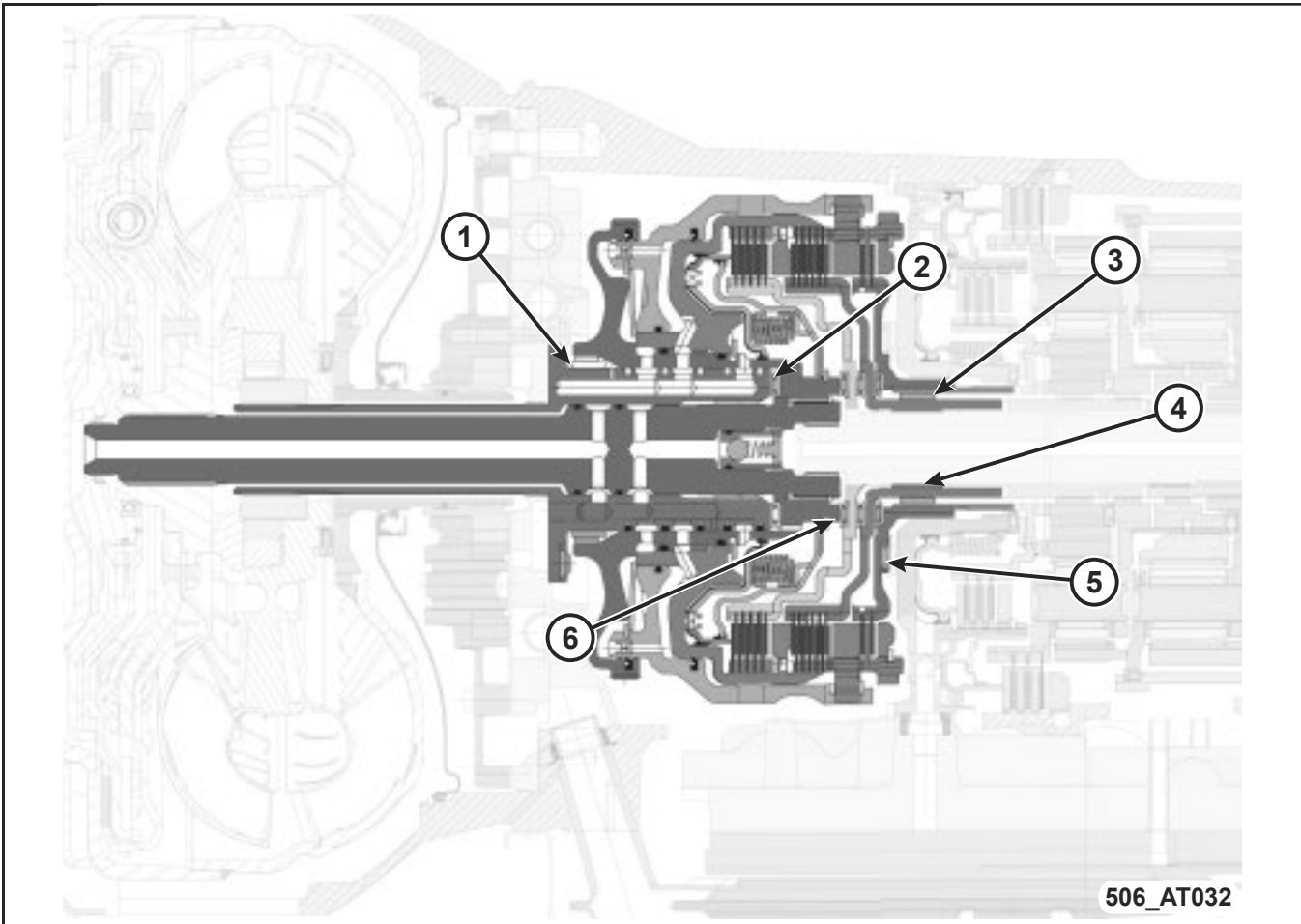

1. Center Support Bearing	4. Reverse Hub Bushing
2. Thrust Bearing #1	5. Thrust Bearing #5
3. Overdrive Hub Bushing	6. Thrust Bearing #2

5. When would noise occur if the source was on the input side?

6. How does brake application affect input support noise?

Gearsets

Instructions: Place an X next to the items in the list below that support the gearset.

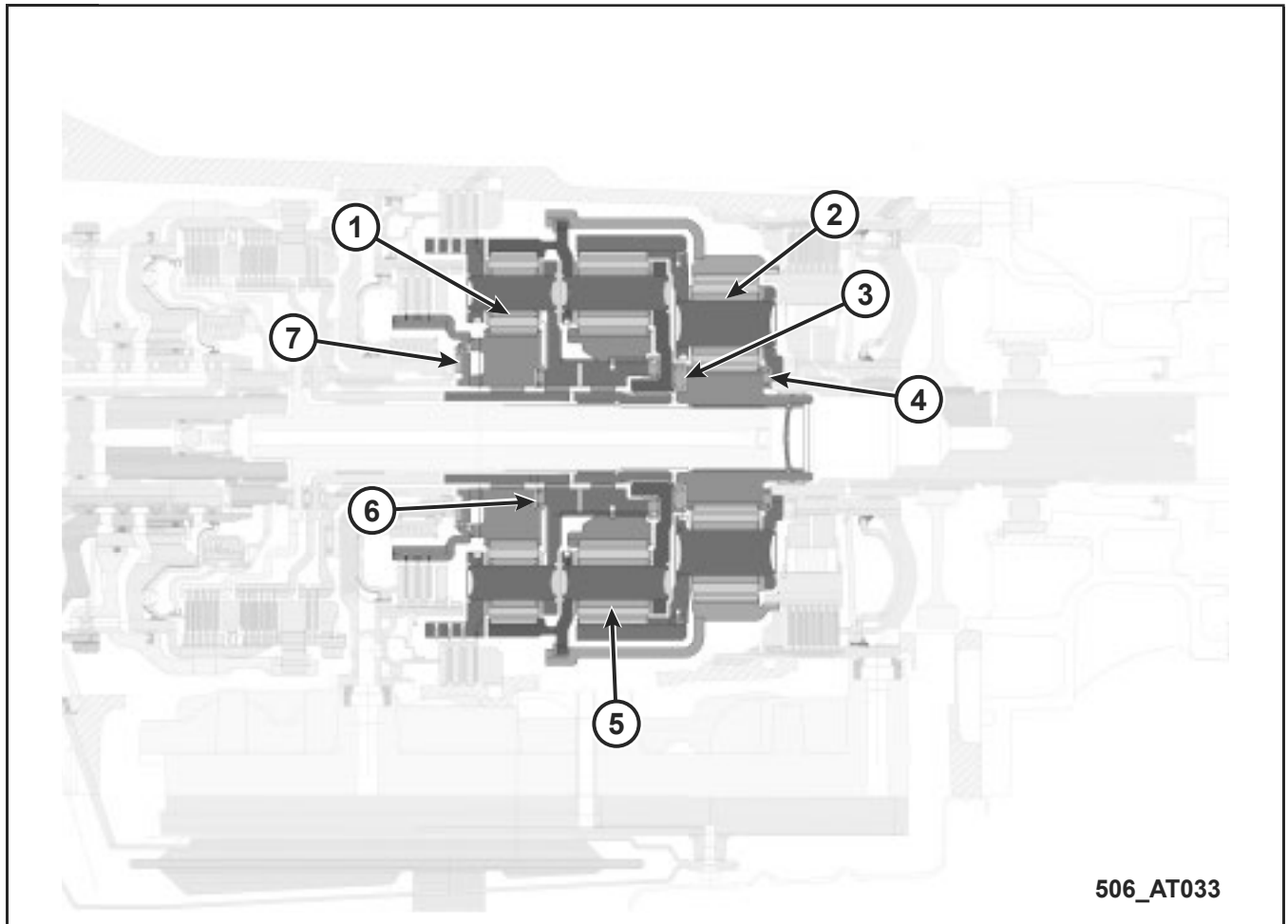

506_AT033

1. Reaction Planetary Pinion Bearings	5. Output Planetary Pinion Bearings
2. Input Planetary Pinion Bearings	6. Thrust Bearing #8
3. Thrust Bearing #10	7. Thrust Bearing #6
4. Thrust Bearing #11	

7. An 68RFE transmission makes noise in both forward and reverse gears. There is no noise in Park or Neutral and the noise is absent in 4th gear. Is the problem a gearset noise? Why?

8. Why would the noise go away in 4th gear?



Gearset Noise Diagnosis

OUTPUT SUPPORT AND FINAL DRIVE

Instructions: Place an X next to the items in the list below that support the output side of the gearset and always rotate at vehicle speed.

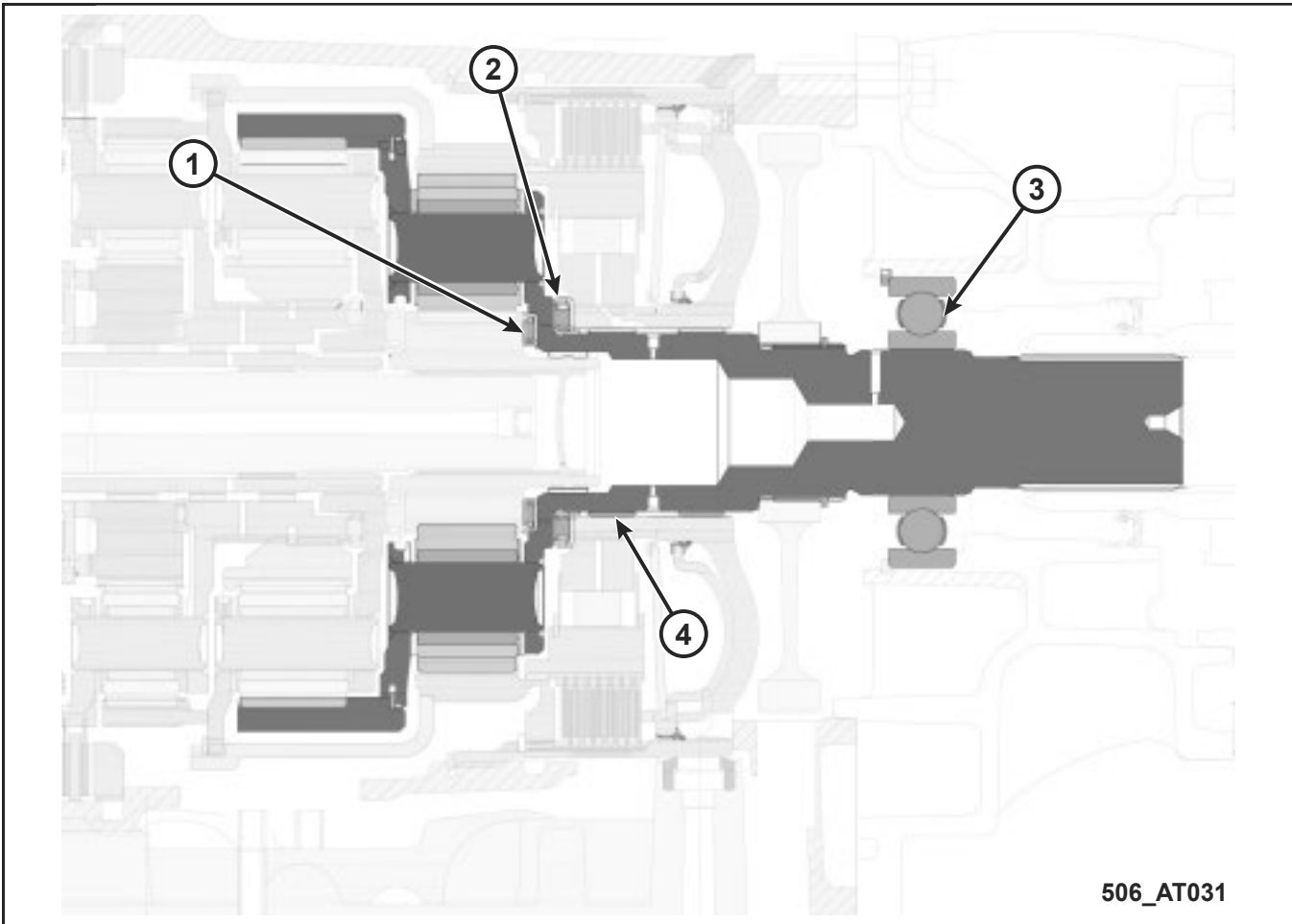

1. Thrust Bearing #11	3. Output Shaft Bearing
2. Thrust Bearing #12	4. Output Shaft Bushing

9. When would noise occur if the source was on the output side?

10. How does brake application affect output support noise?



LESSON 6 CLUTCH ELEMENTS

CLUTCH ELEMENTS

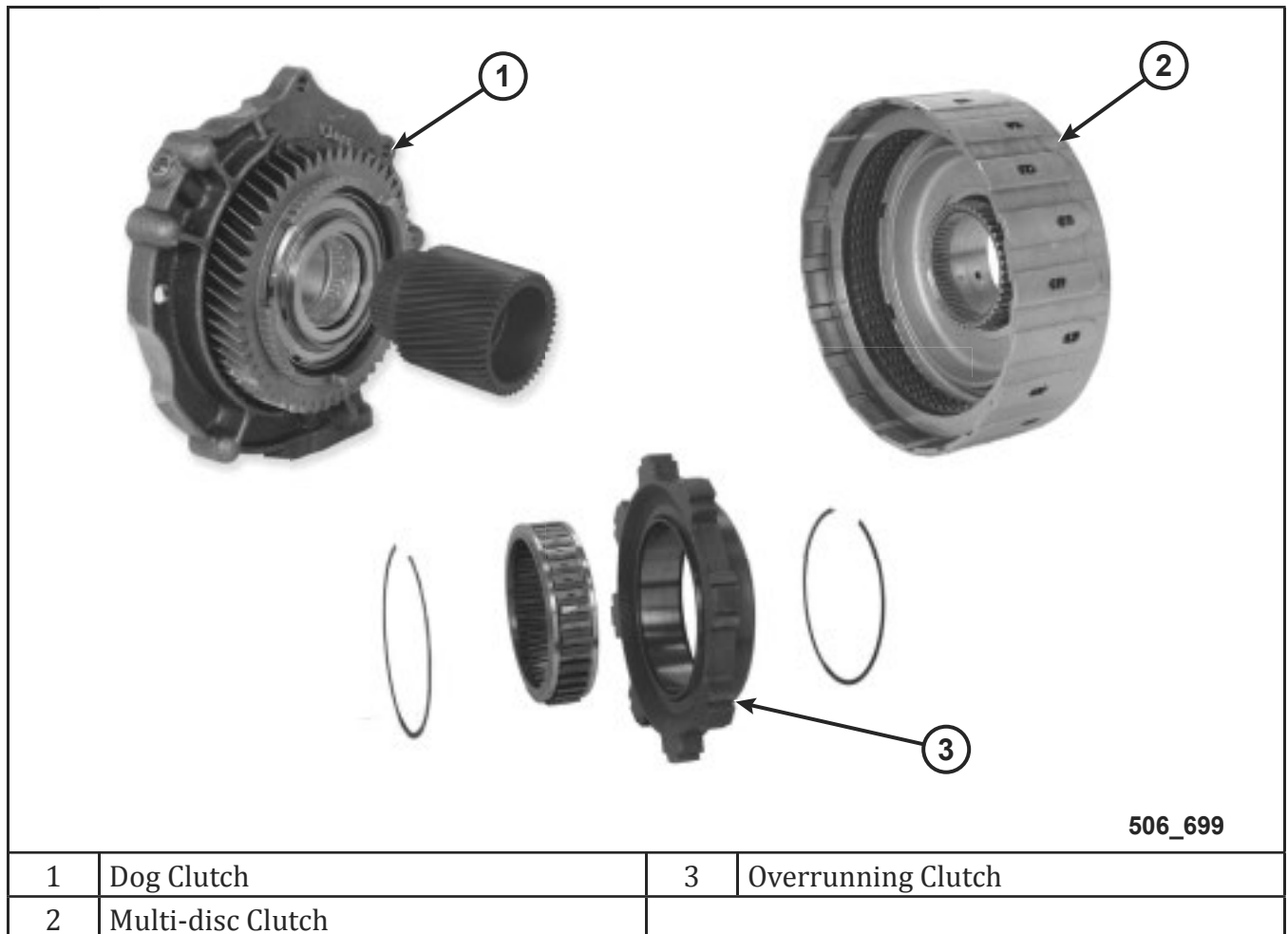

Figure 86 Clutch Types

Clutch elements are the components in the transmission that act on the gearsets and force them to create the various gear ratios. Clutch elements can be broadly divided into two groups: rotating and braking. The rotating clutch elements are used to drive a portion of the gearset at a specific speed. Most rotating clutch elements are directly connected to the turbine shaft. Braking clutch elements are used to hold a component and prevent it from rotating. Braking clutch elements are either connected to the case or to a component connected to the case.

Both groups of clutch elements (rotating and braking) can be further divided into types:

- Multi-disc clutch
- Dog clutch
- Overrunning clutch

Clutch Elements

The overrunning clutch is a purely mechanical clutch element. It does not require any type of control. It simply reacts to the rotational forces inside the gearset. Both the multi-disc and dog clutches require hydraulic control to perform their function. Control is generally provided through the valve body with the operation of the solenoids and the valves. Combinations of applied clutch elements are used to create gear ratios, and the combinations are shown in the clutch application chart. Solenoid control of the clutches is either shown in the clutch application chart or a separate solenoid application chart.

CLUTCH AND SOLENOID APPLICATION CHARTS

Clutch Application Charts

Table 2 Clutch Application Chart (8-speed longitudinal)

Gear	Braking		Rotating			Ratio
	A	B	C	D	E	
1st	X	X	X			4.69:1
1st (NIC)	X	CS	X			NIC
2nd	X	X			X	3.13:1
3rd		X	X		X	2.10:1
4th		X		X	X	1.67:1
5th		X	X	X		1.29:1
6th*			X	X	X	1.00:1
7th	X		X	X		0.84:1
8th	X			X	X	0.67:1
Reverse	X	X		X		3.30:1
Park	X	X				
*	6th gear is limp-home gear					
X	Clutch is applied					

Clutch application charts provide the sequence of application and release of the clutch elements used in a transmission. The design of the chart varies, but all list the available gears and the clutch elements that are required to provide each gear. Many also provide the gear ratio. Clutch application charts are very useful for diagnosis, especially when DTCs are not available.

For example, consider a transmission that has a tie-up condition when the TCM attempts a 4-5 shift. The tie-up condition indicates there is a timing issue where two clutch elements are on at the same time and preventing powerflow. A tie-up abruptly stops rotation in the gearset. Using the clutch application chart, the dynamics of the 4-5 shift can be understood.

Both the B and D clutch remain on in both 4th and 5th gears. Because they do not change state during the shift, they are unlikely to cause the condition. However, both C and E clutches do change state during the 4-5 shift. The E clutch must be released, and at the same time, the C clutch must be applied. If either the C application is too early or the E clutch release is too late, this could result in both clutches being applied at the same time, resulting in the tie-up.

The difficulty is determining which of the two clutches is the most likely source of the problem. The C clutch has been applied and released multiple times prior to the 4-5 shift (released during 1-2 and applied during 2-3). A timing issue with the C would generally appear earlier in the operation of the transmission. The E is the more likely source of the condition because the 4-5 shift is the first time the E is released.

Although the E clutch can be suspected as the source of the condition, the diagnosis must be continued to determine if the root cause is on the control side or a mechanical/hydraulic fault in the clutch assembly. This scenario would generally also result in a ratio DTC.

Clutch Elements

Solenoid Application Charts

Table 3 Solenoid Application Chart

Gear	Solenoid							
	Park (NC)	A (NC)	B (NC)	C (NO)	D (NO)	E (NO)	TCC (NC)	LPS (NO)
P		X	X*	X	X	X		
N	X	X	X*	X	X	X		
R	X	X	X	X		X		+/-
1st	X	X	X		X	X	+/-	+/-
2nd	X	X	X	X	X		+/-	+/-
3rd	X		X		X		+/-	+/-
4th	X		X	X			+/-	+/-
5th	X		X			X	+/-	+/-
6th	X						+/-	+/-
7th	X	X				X	+/-	+/-
8th	X	X		X			+/-	+/-
X	The solenoid is energized							
+/-	The current solenoid is variable (PWM)							
X*	Touch point pressure = the solenoid is energized briefly to fill the clutch circuit in anticipation of upcoming full clutch application							
NC	Normally-closed: when the solenoid is electrically off, the clutch is off							
NO	Normally-open: when the solenoid is electrically off, the clutch is on							

The solenoid application chart is used to supplement the diagnostic information provided by the clutch application chart. The solenoid application chart provides the sequencing of the solenoids that control the clutch elements in each gear.

Generally, the gears are listed down the left side, and the equipped solenoids are listed across the top. Sometimes the type of solenoid will also be listed on the chart.

NC indicates that the solenoid type is normally closed. When the NC solenoid is in its normal or de-energized (off) state, the solenoid blocks the feed pressure and the clutch is released (electrically off=clutch released). The de-energized solenoid also vents the clutch circuit through the solenoid exhaust. These solenoids can also be called normally venting solenoids.

NO on the chart indicates a normally open solenoid. When the NO solenoid is in its normal/ de-energized state, the solenoid allows feed pressure through the solenoid into the clutch apply circuit (electrically off = clutch applied), opposite of the NC solenoid. These solenoids can also be called normally applied solenoids.

Many charts use an X to indicate an energized solenoid. The chart provides the electrical state of the solenoid and not the state of the clutch (applied/released). With NC solenoids, an X indicates that the clutch is applied. However, NO solenoids are different, and the X indicates that the solenoid is on and the clutch is released.

Using the same 4-5 shift tie-up example from the clutch application chart, B and D clutches remain applied during the shift, C is applied, and E is released. The solenoid application chart shows that B solenoid is on in both gears, and because it is NC the clutch is applied. The D solenoid is off in both gears, and because it is NO, the clutch is applied. The C solenoid changes state from on in 4th gear to off in 5th gear. Because C solenoid is also an NO solenoid, the clutch transitions from released to applied when the solenoid was turned off. The E solenoid, also NO, changed state (opposite of C) from off to on, causing the clutch to release during the shift.

Again, the diagnosis from the clutch application chart indicated the most likely cause of the condition was related to the E clutch being released too late. The E solenoid could contribute to this by being energized too late (delayed). This could be the result of excessive resistance in the circuit, TCM malfunction, or solenoid malfunction (restricted flow). It could also be in the hydraulic circuits within the valve body.

Although the solenoid application chart is very useful in diagnostics, it does not always provide a complete picture of the control side of the clutch. This is why understanding hydraulic circuits is important. For example, transmissions equipped with a manual valve often provide reverse gear without requiring operation of the solenoids. The manual valve is also typically part of any limp-home strategy, providing hydraulic default gears.

Clutch Elements

HYDRAULIC CONTROLS

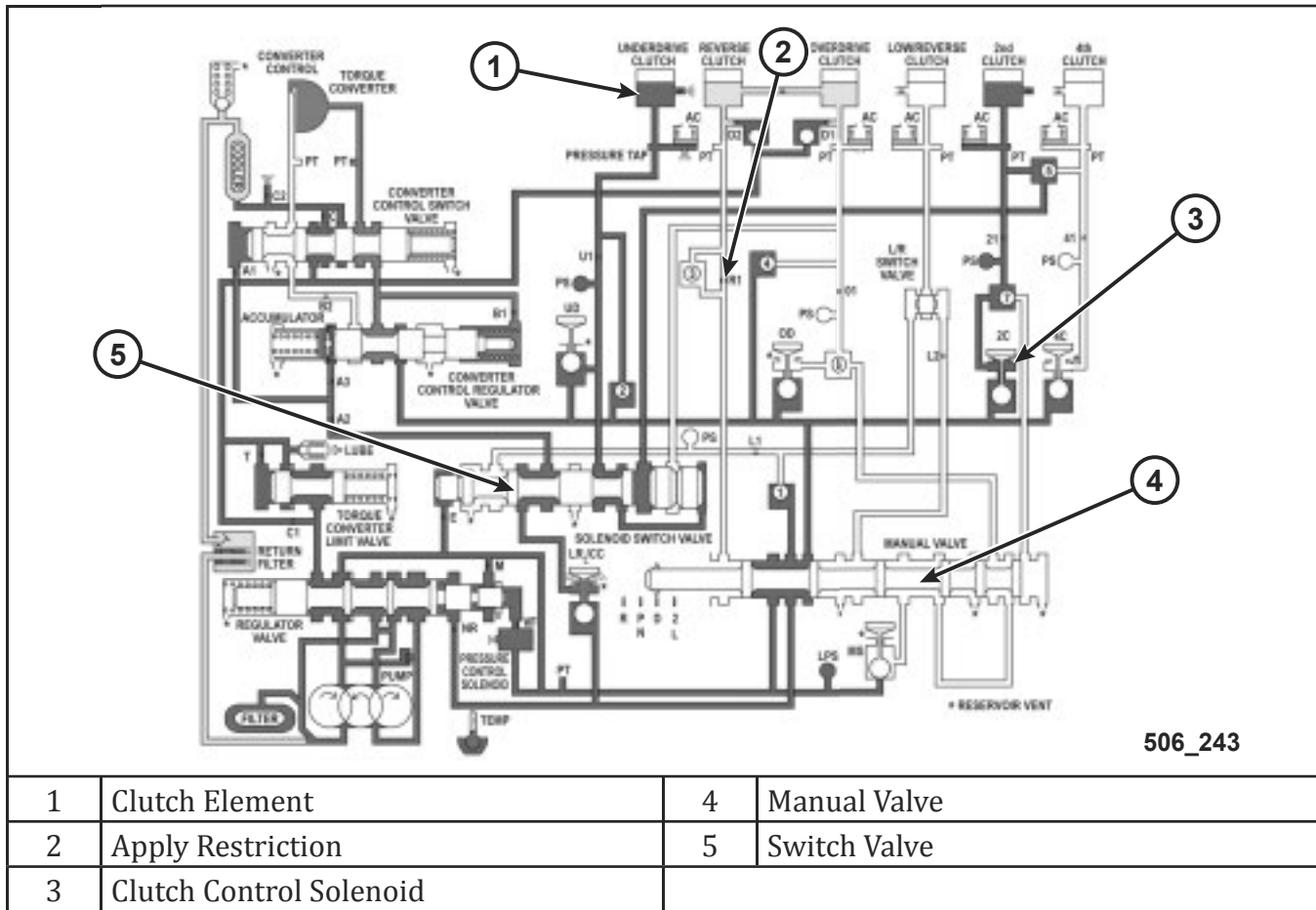

Figure 87 Hydraulic Controls

Automatic transmissions use hydraulic circuits to control the application and release of most clutch elements (excluding overrunning clutches). Clutch control generally includes:

- A controller that determines when to apply and release the clutch
- An electrical solenoid that controls hydraulic fluid to the clutch based on the controller electrical signal
- Valves and other components to direct the fluid to the correct clutch and adjust the shift quality

Some transmissions also include manual valves and other mechanical methods to control the application or release of clutches under certain conditions (for example, reverse and limp-home mode).

Hydraulic control attempts to achieve correct shift timing and shift quality. Shift timing provides the correct gear for the vehicle conditions (primarily engine load versus vehicle speed). Shift quality is the feel of the shift (firm/harsh, normal, or soft/slipping). Shift quality is very subjective and requires engineering to balance durability with customer comfort. A firm shift increases durability, but can be perceived as too harsh. A soft shift increases the friction load in the slipping clutch pack and can reduce durability; however, many customers prefer a softer shift instead of a shift that is too firm.

Solenoids

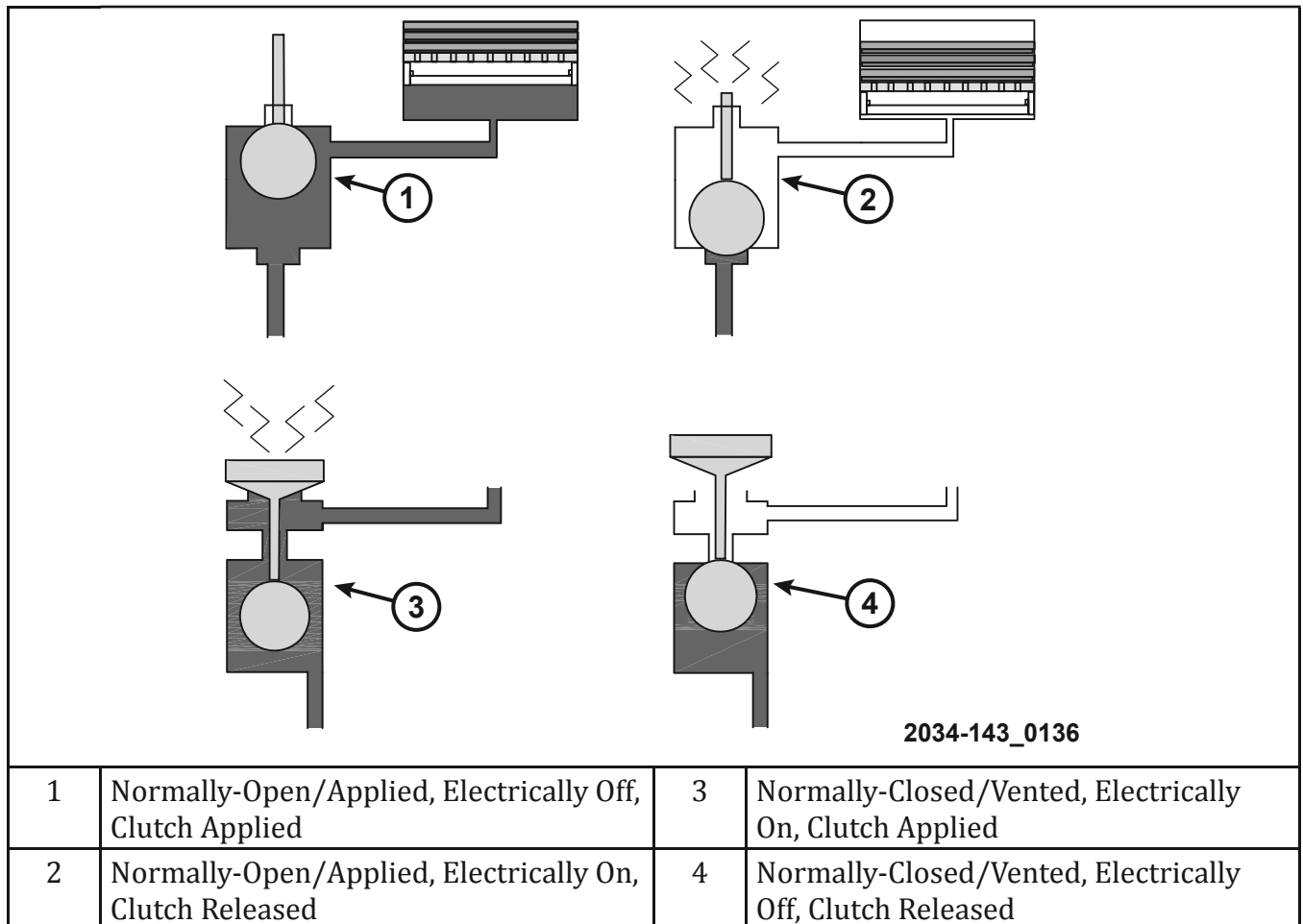

Figure 88 Normally Applied Solenoid Operation

The solenoids used to control clutches vary based on the transmission. There are two basic types of solenoids: on/off and pressure regulating. The on/off solenoids provide two states and are voltage controlled. The pressure regulating solenoid provides variable hydraulic control between fully off and fully on electrically. The pressure regulating solenoids have various names (variable force solenoid, pressure control solenoid, pulse-width-modulated, linear solenoid) depending on how they are designed; however, all achieve the same goal of varying the pressure applied to a clutch. Pressure regulating solenoids are extensively used for clutch control in newer transmissions.

Both types of solenoids are available in normally-open/applied and normally-closed/vented designs. The term normally indicates the de-energized state. Open or closed describes the state of the solenoid passage between the fluid source and the clutch apply circuit. Applied or vented is the state of the clutch apply circuit. Normally-open/applied solenoids connect the fluid source to the apply the clutch when de-energized. Normally-closed/vented solenoids block the fluid source from the clutch apply circuit when de-energized. In this position, the solenoid connects the clutch apply circuit to the solenoid vent, releasing the clutch.

Clutch Elements

Check Balls

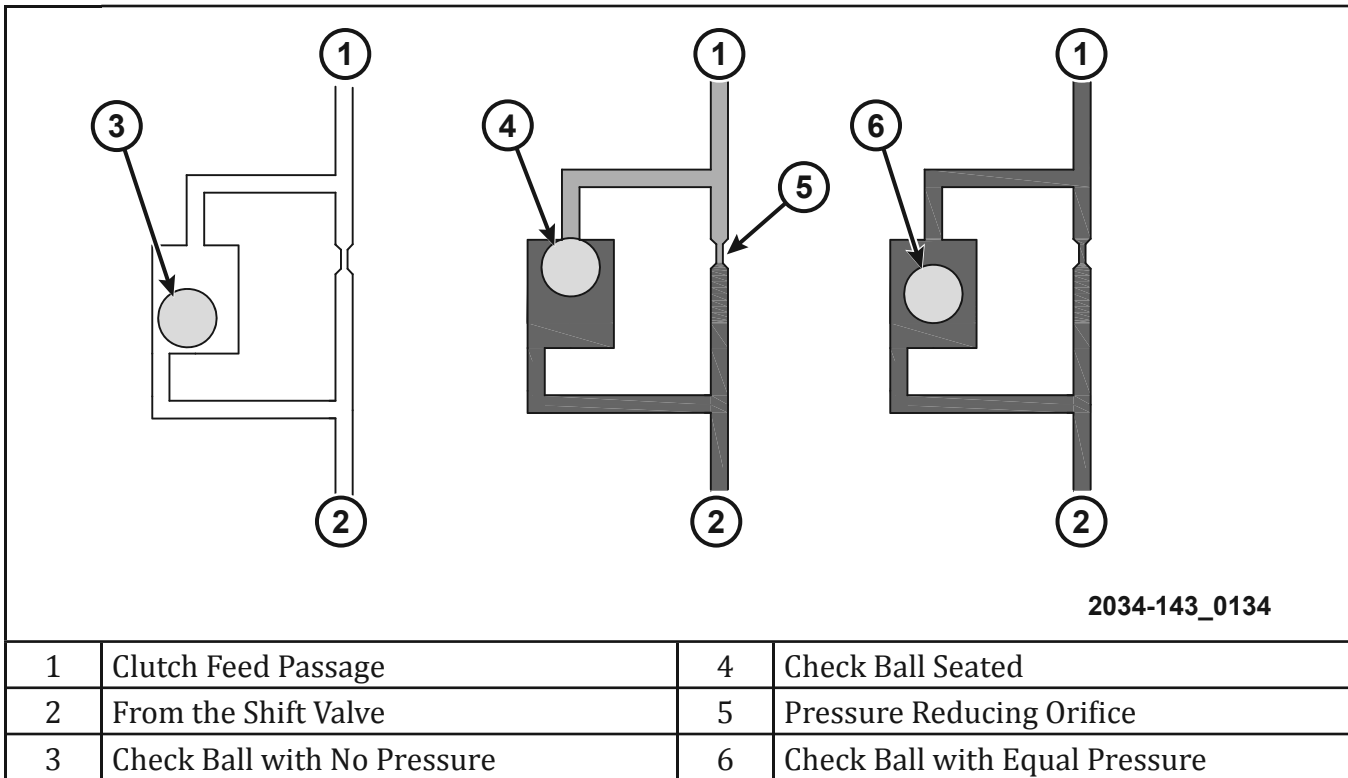

Figure 89 Check Ball Controlled Orifice Circuit Operation

Most transmissions use hydraulic system check balls. A check ball in the hydraulic system of an automatic transmission can be seated to block the flow of fluid or unseated to allow the flow of fluid as pressure increases or decreases.

A check ball can be used along with an orifice so that the following action occurs:

- When the check ball is seated, all fluid must flow through the orifice.
- When the check ball is unseated, fluid can flow through the orifice and also past the check ball.

Spool Valves

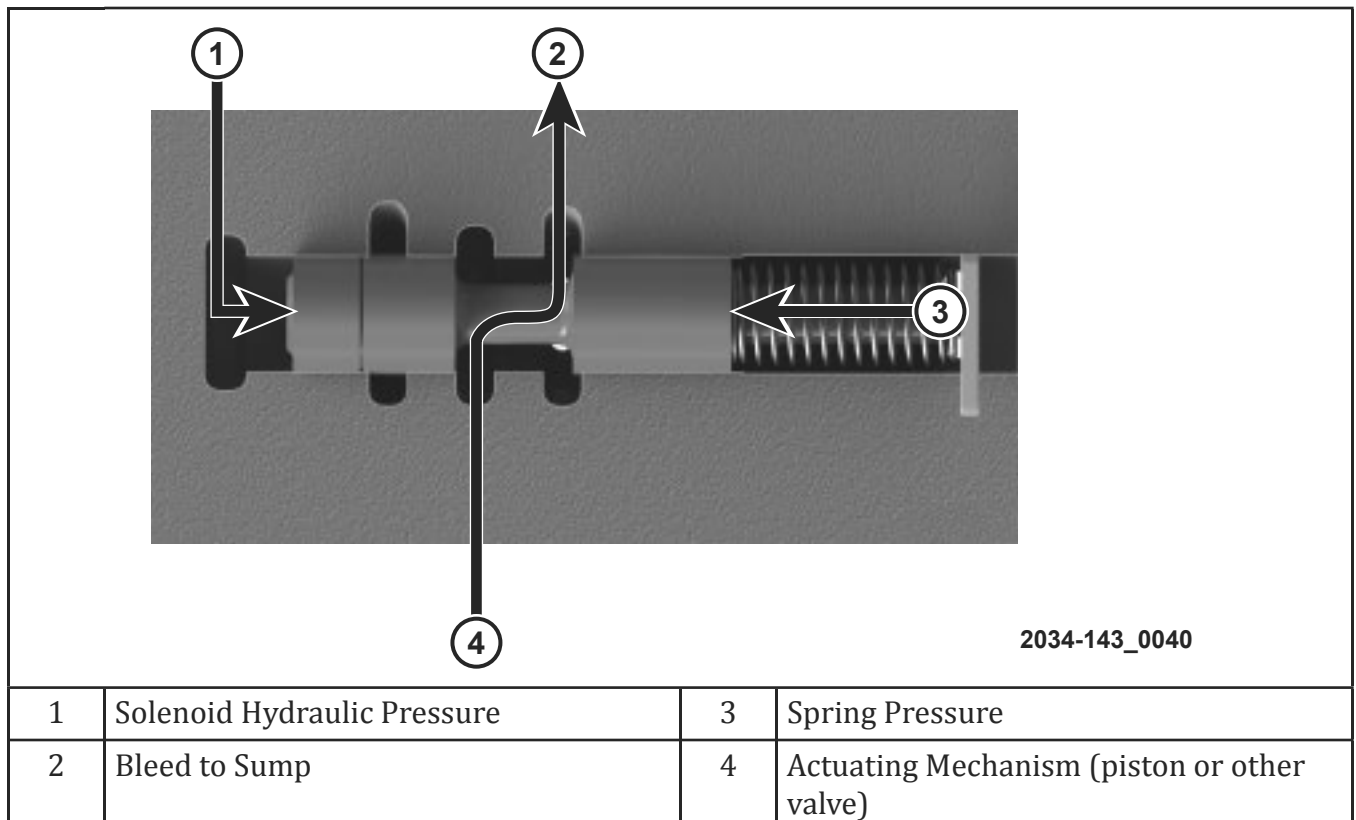

Figure 90 Spool Valve Operation

Most transmissions have hydraulic control systems that use spool valves. A spool valve has a face on each of its ends and one or more valleys located between its lands. A spool valve is positioned in its bore by opposing forces acting on its faces.

This spool valve connects two different oil passages and controls the oil flow between the two. The valve can move in one direction or the other in a bore, opening or closing another passage. The valve moves left or right, according to which force is greater.

When the spring force is greater than the hydraulic force, the valve is pushed to the left, closing the passage.

When the hydraulic force builds up enough force to overcome the spring force, as shown in the graphic, the hydraulic force strokes the valve to the right, compressing the spring even more and redirecting the fluid up into the passage. When there is a loss of pressure due to the redirection of oil, the spring force closes the passage again.

Clutch Elements

Accumulators

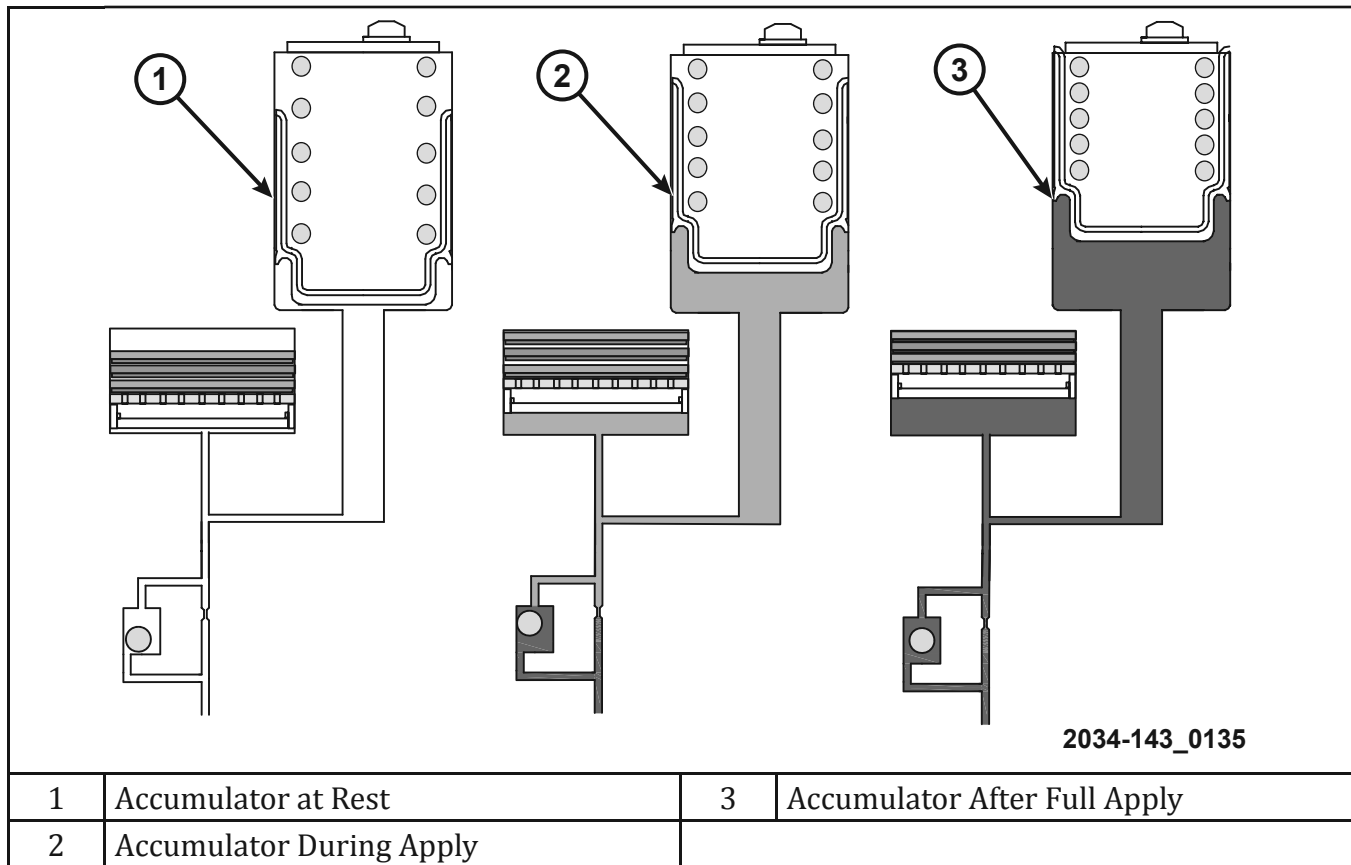

Figure 91 Accumulator Operation

Some transmissions use hydraulic system accumulators. An accumulator is a hydraulic device that cushions the application of a clutch. An accumulator consists of a piston and one or two springs located in a bore in the transmission case or valve body. When a clutch is hydraulically applied, clutch application is dampened when fluid fills the accumulator bore and pushes against the piston and springs of the accumulator.

Manual Valve

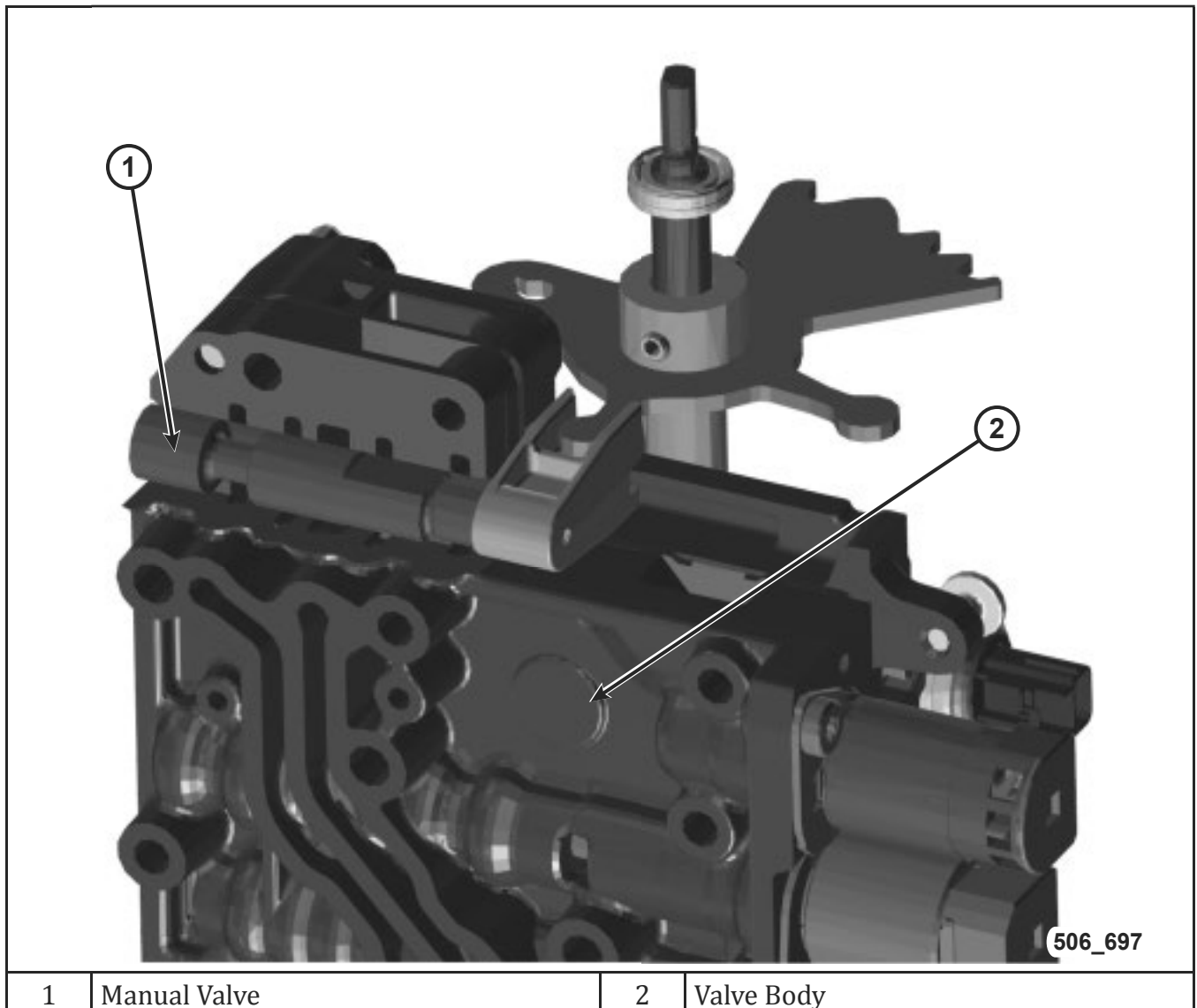

Figure 92 Manual Valve

The manual valve is fed by line pressure from the pressure regulator valve and is mechanically linked to the gear selector lever. The manual valve is usually located in the transmission valve body.

When a gear range is selected, the manual valve directs line pressure into the various circuits by opening and closing feed passages to the solenoids and clutches, depending on the specific transmission.

For example, some clutches required for Reverse are directly supplied from the manual valve.

When Drive is selected, the manual valve supplies solenoids and switching valves with line pressure for clutch application. Manual drive positions generally provide a direct passage to specific clutches.

Clutch Elements

Non-Manual Valve

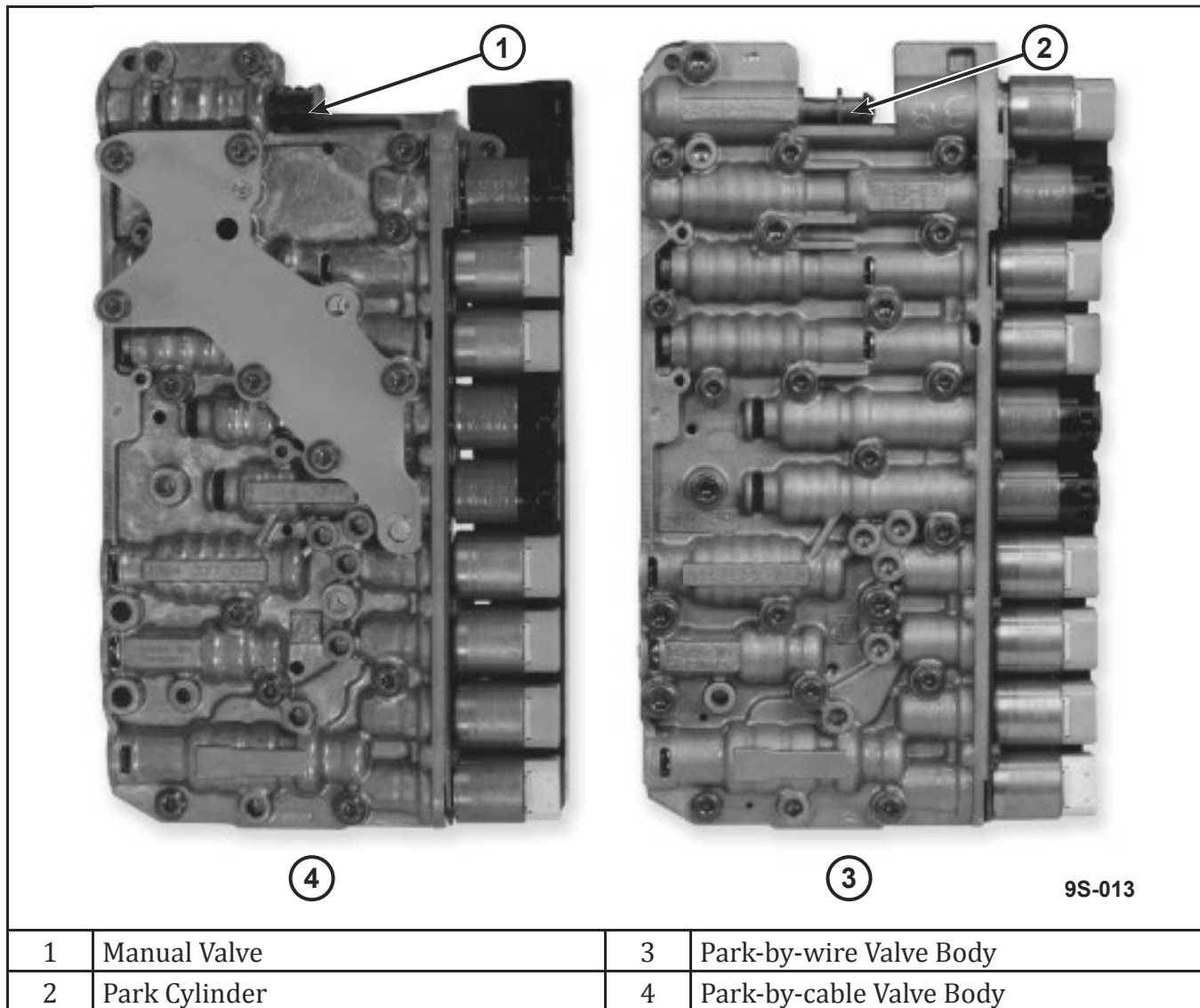

Figure 93 Valve Body Variants

The 948TE can be equipped with one of two valve bodies. The park-by-wire valve body has an additional solenoid, and the park-by-cable valve body has a manual valve. The park-by-cable system provides Reverse and one forward gear in limp-home mode. The park-by-wire system does not provide a limp-home mode.

Non-Manual Valve (continued)

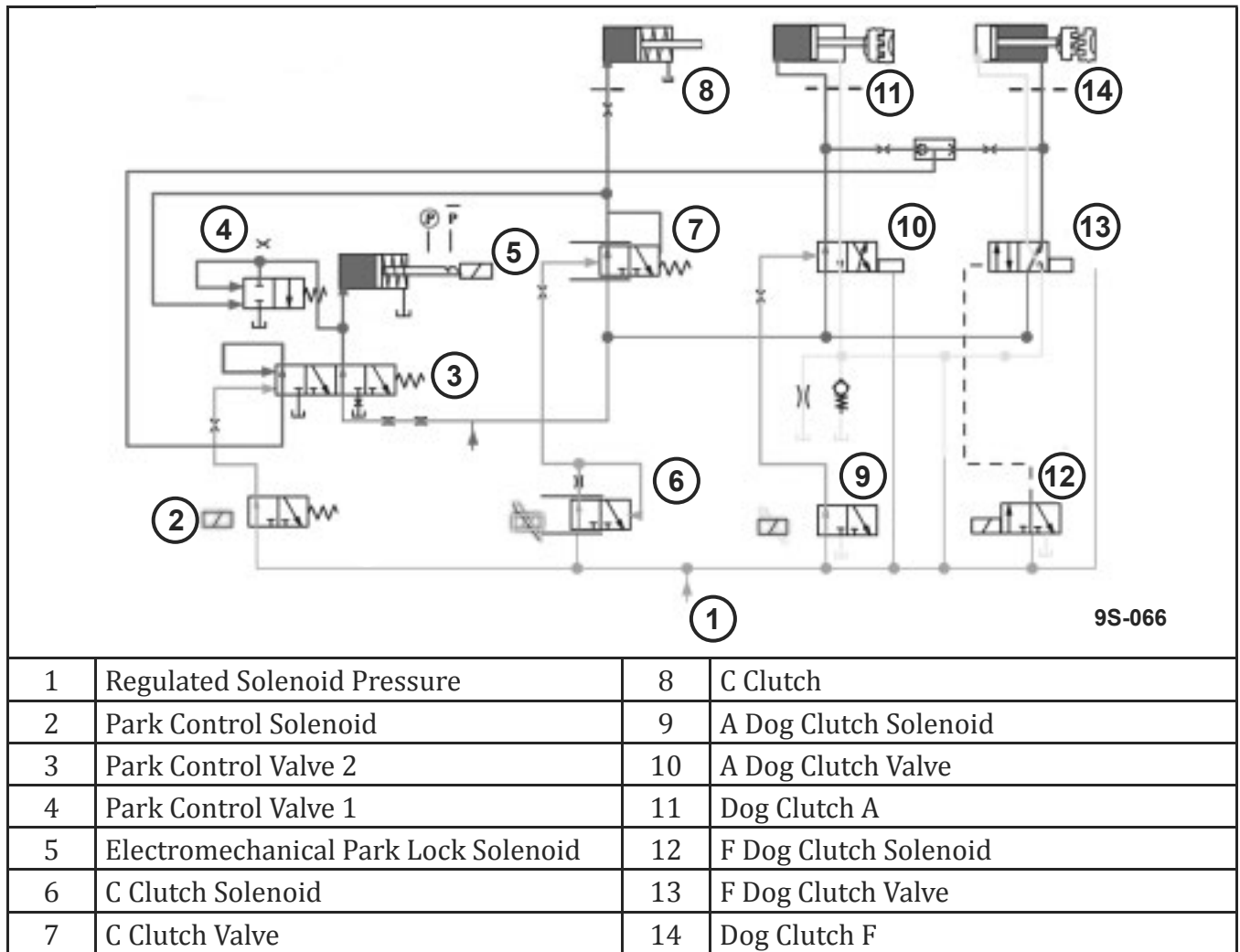

Figure 94 Park-by-wire Hydraulic Diagram

The park-by-wire valve body uses an on/off solenoid to position the park cylinder valves (PCV). The solenoid is off in Park and on in all other ranges. When the solenoid is on, the valves are positioned so that the park cylinder valve is moved out of the Park position and held by the mechanical solenoid. The system is designed to prevent the transmission from shifting to Park during an electrical issue. The pressure is maintained at the park cylinder valve by the A dog circuit when applied (gears 1–7), and by the F dog when released (gears 5–9). The applied C clutch maintains the pressure if an electrical fault occurs in the middle of transmission braking during a rock cycle.

If the transmission is not in Park and a malfunction occurs where either the solenoid power is lost or turned off by the TCM, the F dog hydraulic release circuit pressure prevents Park. This pressure maintains the park control valve 2 position when the park control solenoid is turned off. The release pressure maintains valve position until the engine is turned off or the transmission pump stops providing pressure.

Clutch Elements

Limp Modes

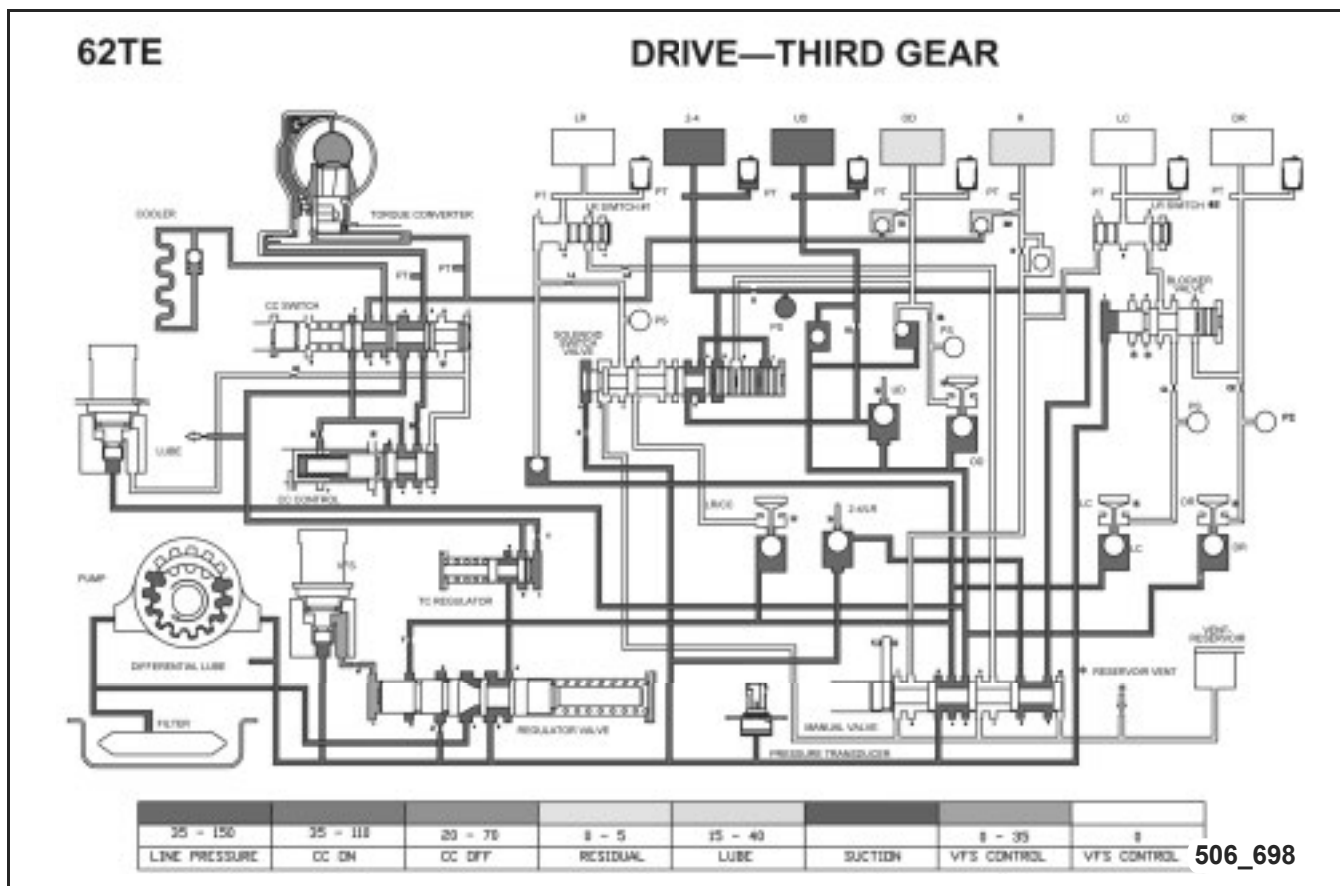

Figure 95 62TE 3rd Gear Limp-home Hydraulic Schematic

Most transmissions with electronic controls have a backup mode of operation when electrical power is lost or there is a concern that could damage the mechanical components of the transmission. This is usually called limp-in or limp-home mode. This backup mode allows the customer to get the vehicle home safely and without transmission damage.

Limp-home is achieved by using normally-open and normally-closed solenoids in the transmission in such a way so that when electrical power is not available, the transmission reverts to hydraulic control based on the manual valve position and de-energized solenoid state. Most transmissions provide Park, Reverse, Neutral and one forward gear, available in Drive, depending on the specific transmission.

In the graphic shown, notice how the 2-4 clutch is supplied right from the manual valve and has no solenoid, and the UD clutch has a normally-open solenoid, allowing the two clutches to apply without electric power.

Limp Modes Examples

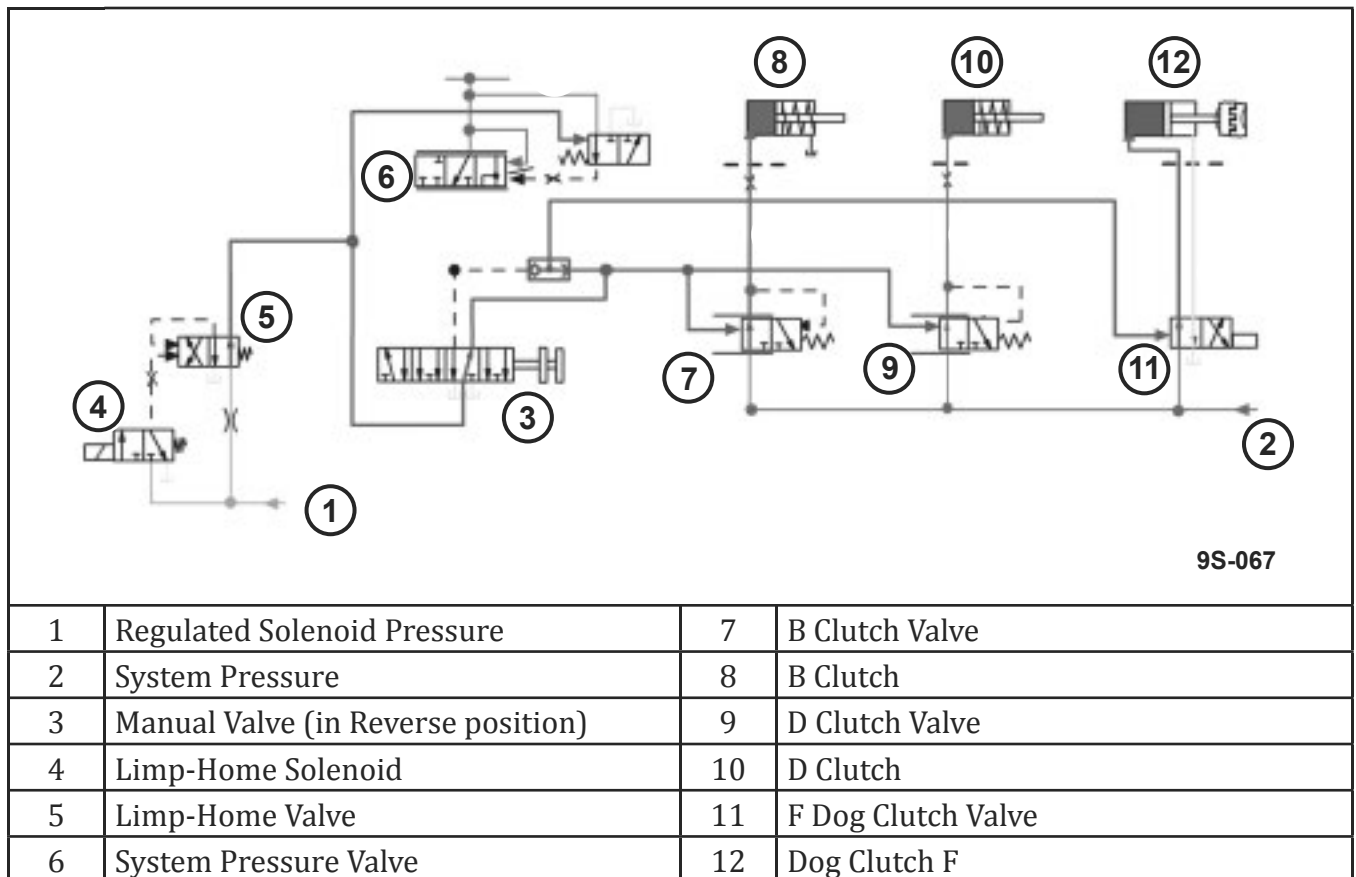

Figure 96 Limp-home Reverse Hydraulic Diagram Example

Nine-speed, park-by-cable transmissions have a Reverse limp-home mode. During normal operation, the limp-home mode solenoid is on and positions the limp-home valves to block fluid to the limp-home circuits. When the solenoid is de-energized, fluid is allowed into the limp-home circuit, which moves the system pressure valve to maximize pressure. It also directs fluid to the manual valve and the clutches required for Reverse (B, D, and F dog).

The Drive limp-home mode is similar to Reverse limp-home mode because the manual valve is used to apply the clutches for Drive.

Some newer transmissions do not have a manual valve. Some of these transmissions do not provide a limp-home mode.

CLUTCH OPERATION

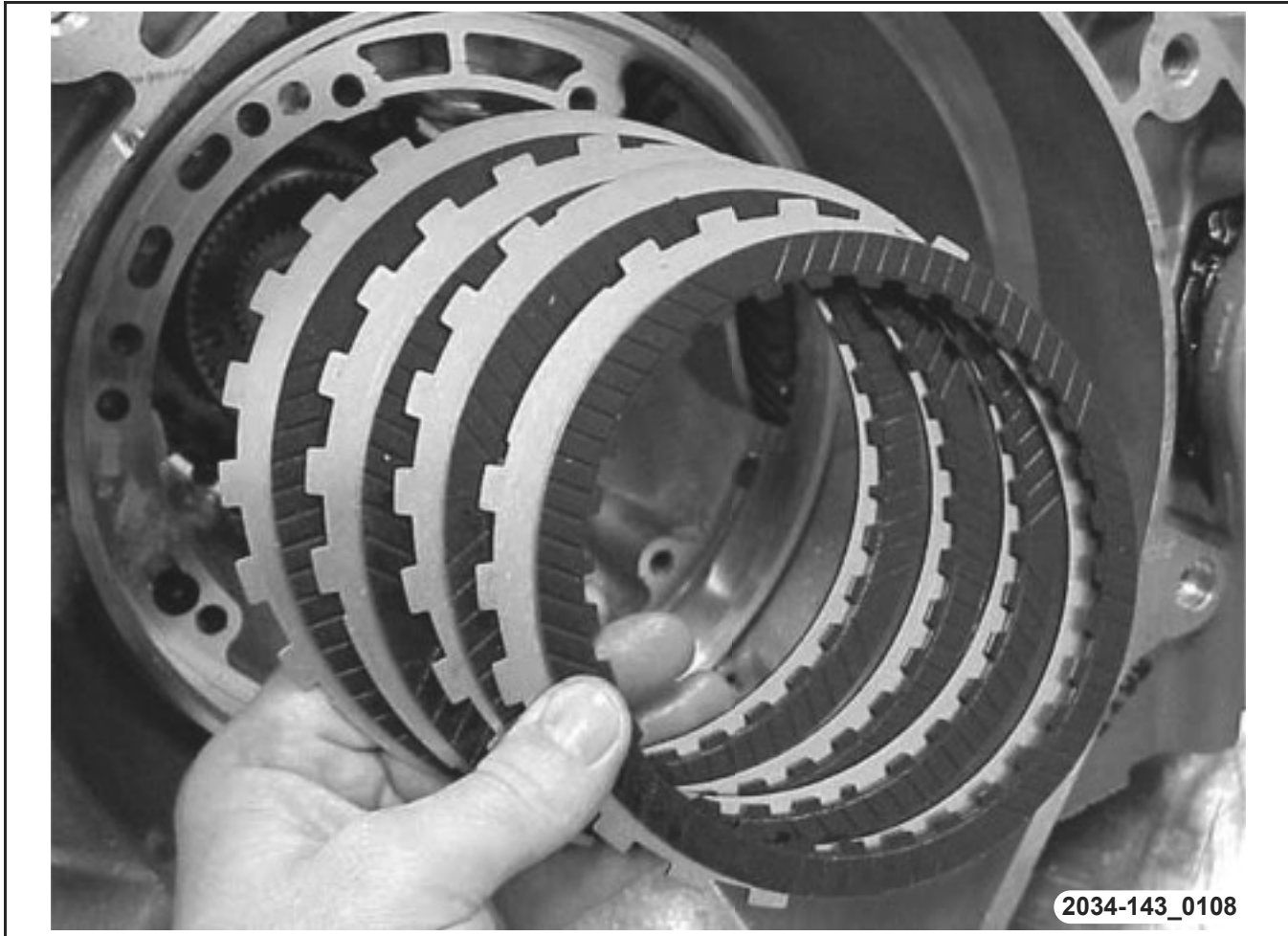

Figure 97 Multi-disc Clutch Pack

Most automatic transmissions use multi-disc clutch assemblies. The clutches are used to drive or hold members of the planetary gearset. Multi-disc clutches are commonly referred to as clutch packs.

Multi-Disc Clutch Operation

During clutch engagement, pressurized fluid enters the area behind the clutch apply piston. The fluid forces the piston against the friction discs and steel plates. The friction discs and steel plates become locked together, forming a unit. The friction discs connect to a hub, the steel plates connect to a retainer, and the clutch rotates as a unit to transfer power through the assembly.

When hydraulic fluid is exhausted from behind the piston by use of a check ball or vent, the return spring pushes the piston away from the friction discs and clutch plates. The friction discs and clutch plates are no longer locked together, and no power is transferred through the clutch.

Snap Ring

Figure 98 Tapered Snap Ring (typical)

Snap rings are used in transmissions to retain components such as reaction plates, gears, or bearings, and to limit the travel of a piston or clutch pack assembly when actuated. In some cases, the snap ring is a selectable thickness and is used to adjust clutch pack clearance. Snap rings may also have a wave feature to help cushion the application of a clutch. Other snap rings are tapered to ensure that the snap ring seats completely into its groove.

Clutch Elements

MULTI-DISC CLUTCH

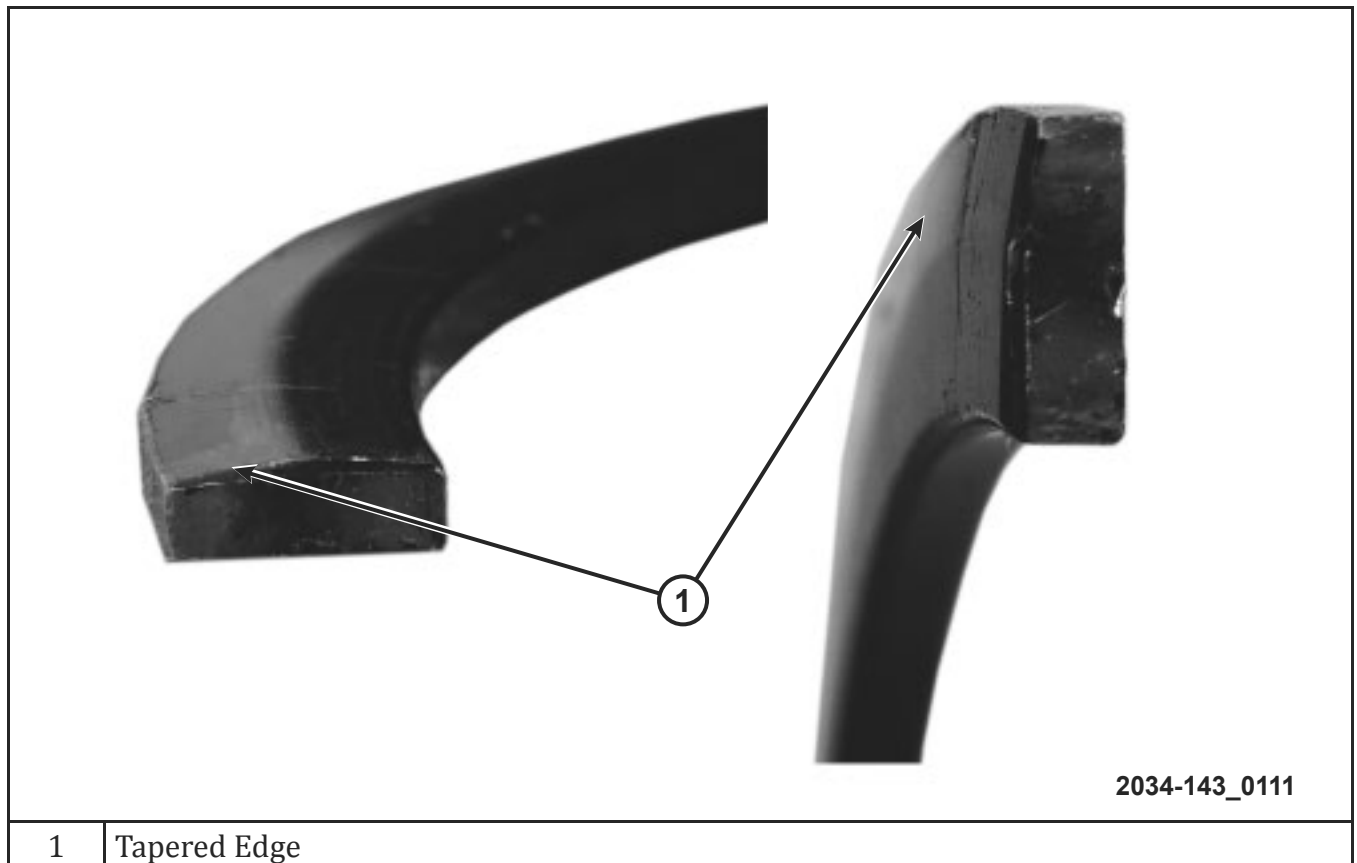
Multi-Disc Clutch Components

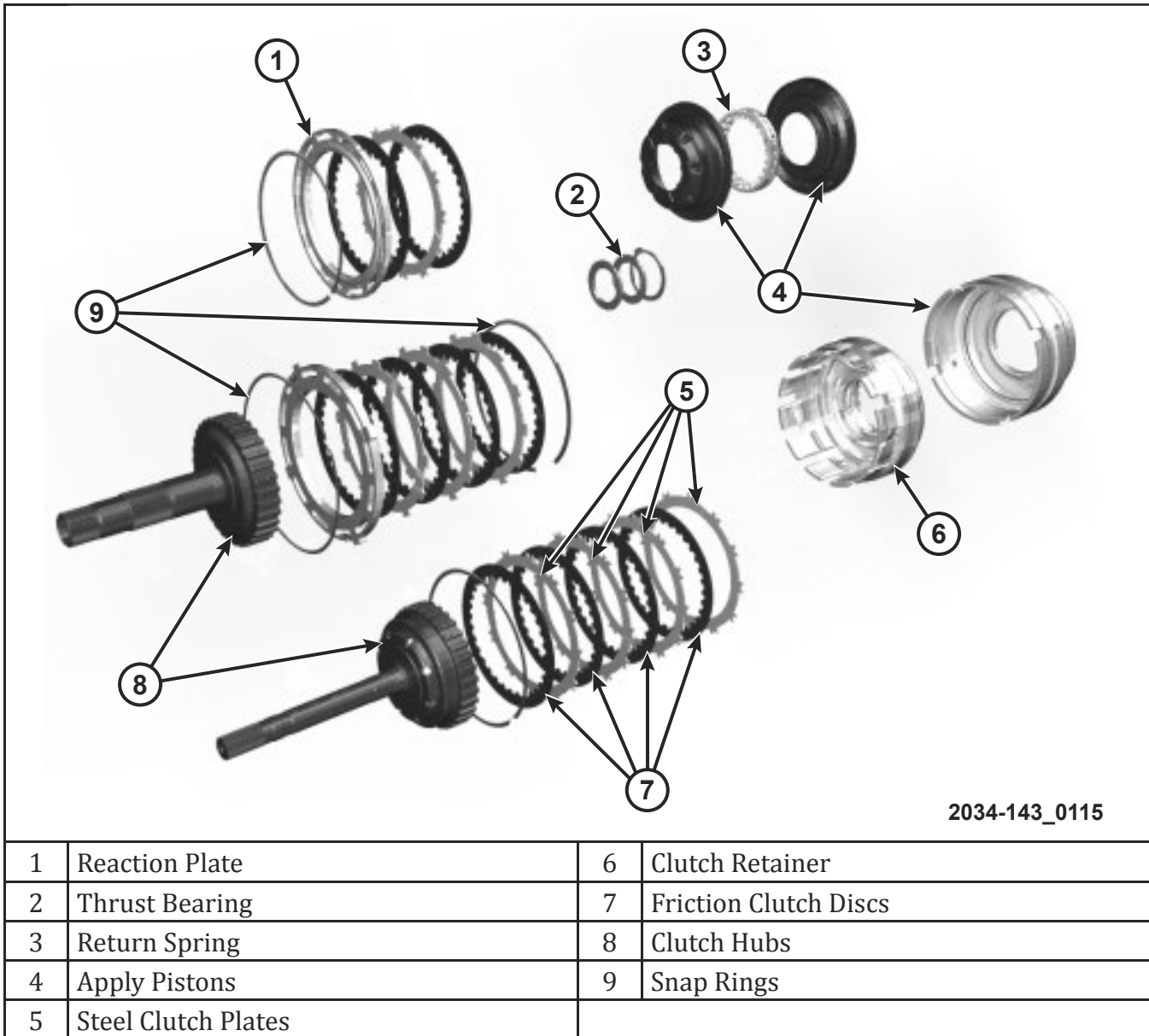

Figure 99 Typical Clutch Pack Construction (RFE input housing shown)

Clutch Retainer

The clutch retainer is the housing for all clutch components. The inner diameter contains large splines, which spline with lugs on the steel clutch plates.

Friction Discs

Clutch friction discs (frictions) are metal plates with integrated friction lining material, similar to the friction material used in brake pads. The discs have internal splines that engage splines on the clutch hub. Some drive discs use a design with friction material on both sides of the metal plate. Other drive discs have a design with friction material on one side only.

Separator Plates

The clutch separator plates (steels) look like the drive discs, but they do not have friction lining. Also, they have external splines instead of internal ones. These splines engage the splines in the clutch retainer. The friction discs and separator plates form a sandwich of alternating layers and lock together the retainer (or drum) and hub, and parts connected to each (planetary members), when the clutch is applied.

Clutch Elements

Clutch Hub

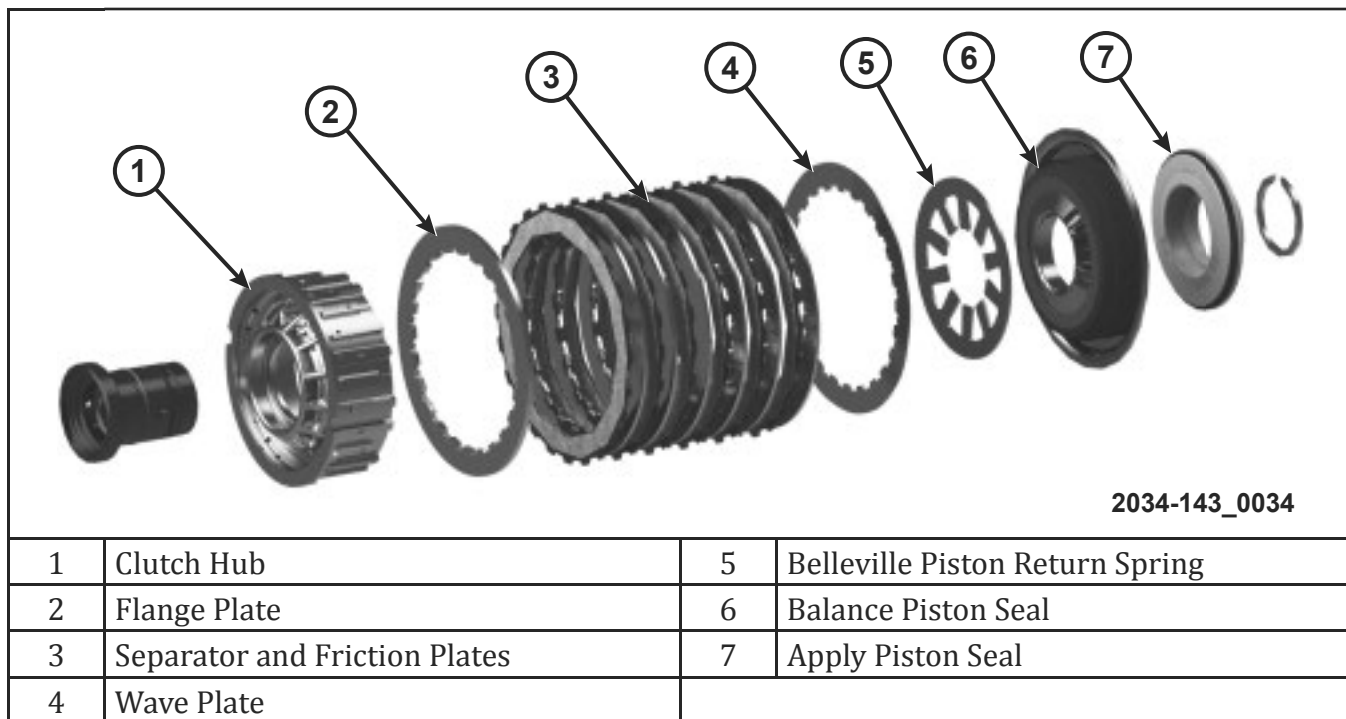

Figure 100 Clutch Hub (8HP45 C clutch shown)

The clutch hub may be comprised of a part within the clutch pack, or it may be part of another component, such as the planetary ring gear/annulus. The hub fits into the inside diameter of the set of friction discs and clutch plates. External splines on the hub engage the internal teeth of the friction discs. The clutch hub may also be splined to the transmission input shaft or to a part of the planetary gearset.

Return Spring

The clutch return spring is used to push the apply piston away from the clutch pack after hydraulic pressure is released by a check ball or vent. Return springs may be one of several different designs. Types of return springs include: large coil, a series of small individual coils, or a Belleville spring.

Pressure/Reaction Plate

The reaction plate serves as a stop (end of travel) for the set of friction discs and separator plates when the clutch is applied. When the clutch is applied and compresses, the reaction plate stops against a snap ring and reacts to the force, transmitting torque to a splined component.

Apply Plate

The clutch pressure plate, located against the apply piston, transmits force from the piston to the clutch pack as the piston is actuated. The end steel separator plate serves as the pressure plate in many applications. The pressure plate is often accompanied by a wave plate that helps cushion the clutch application. Harsh shifts may occur if the wave plate is left out during assembly.

Apply Piston

Figure 101 Clutch Pistons (8HP45 shown)

The clutch apply piston is a disc that fits into a piston bore in the lower portion of the clutch drum. The piston is moved by hydraulic pressure. Movement of the apply piston clamps the friction discs and clutch plates together. A piston has outer and inner piston seals that fit around the respective diameters of the piston to prevent fluid loss and consequent pressure loss when the piston is applied. With some pistons, the outer and inner piston seals are bonded to the body of the piston.

Balance Chamber

The apply piston chamber typically has fluid within it even when the clutch is disengaged. If the clutch is rotating, centrifugal force causes that fluid to press against the outer edges of the piston chamber. This force creates a small amount of drag in the clutch pack, which can reduce fuel economy and the clutch disc life.

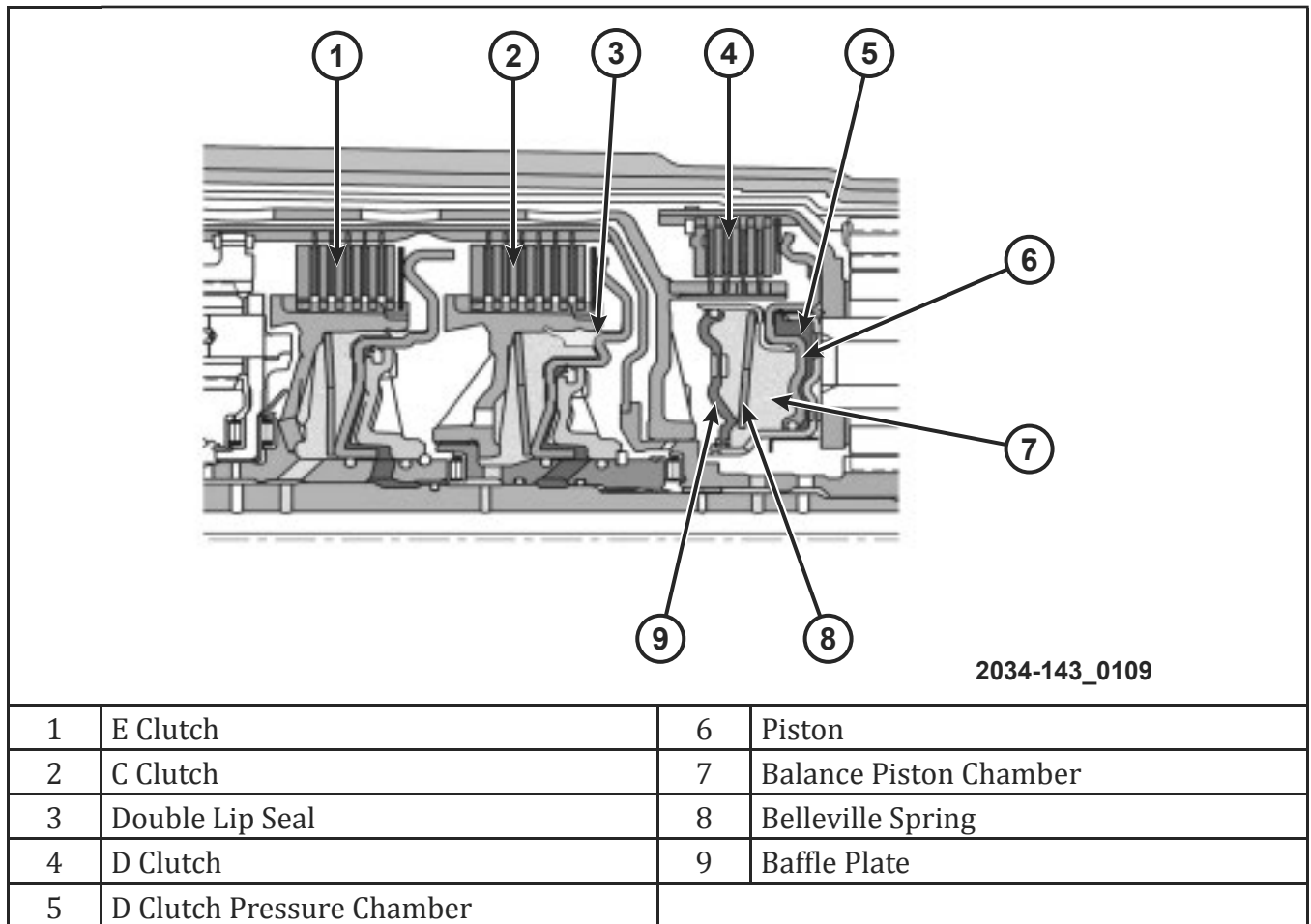
A balance chamber holds fluid on the release side of a clutch apply piston. Because both sides of the apply piston are rotating at the same speed, the same amount of centrifugal force pressure is generated on both sides of the piston, eliminating any potential drag.

Clutch Elements

Piston Seal Types

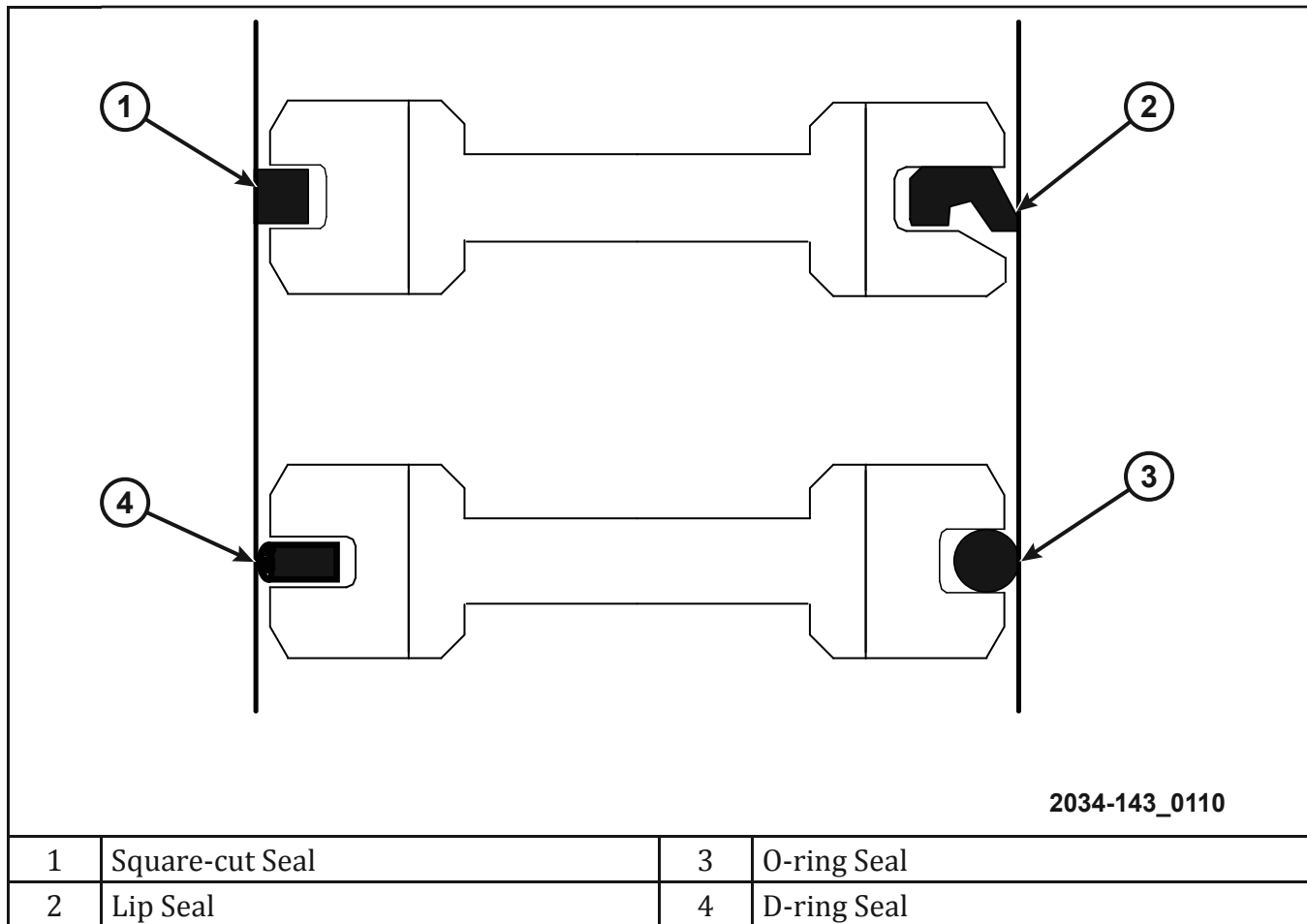

Figure 102 Rubber Seal Types

Today's automatic transmission clutch circuits use various types of rubber seals to seal off fluid under pressure. Elsewhere in the transmission, rubber seals prevent fluid from leaking out of the transmission, and they are also used to prevent dissimilar fluids from mixing or contaminating each other.

The rubber seals are compositions of silicone, polymers, and other elastomers to ensure the seal is both flexible and long-lasting. The graphic shows some of the more common rubber seal types.

OVERRUNNING CLUTCHES

Roller-Type

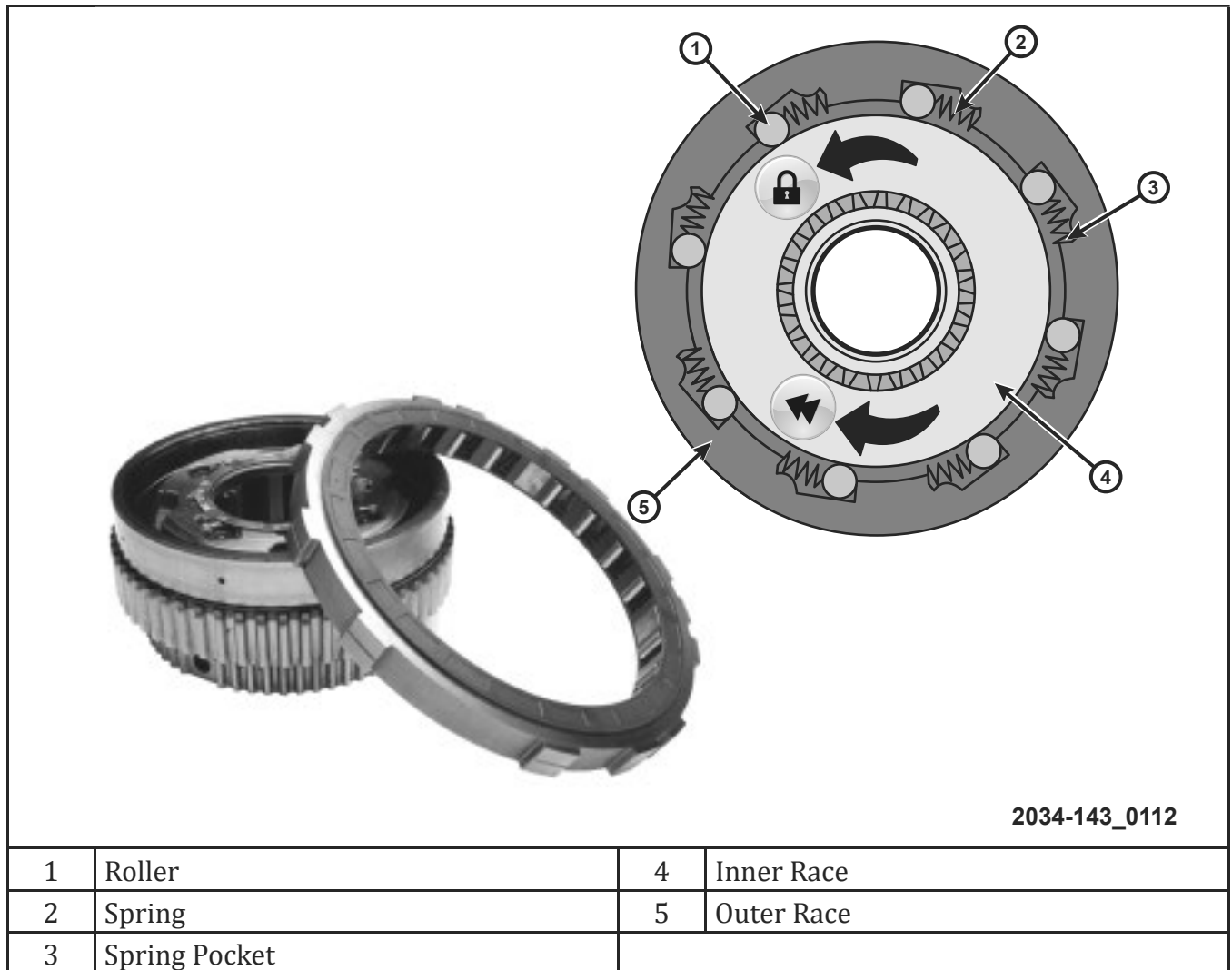

Figure 103 Roller-type Overrunning Clutch

Overrunning clutches (one way clutches) are mechanical holding devices. They can be used to hold planetary gearset members to improve the shift quality and timing of the transmission/transaxle. An overrunning clutch is also used with the stator of a torque converter to improve efficiency. There are a few different types of overrunning clutches, although all types operate the same.

A typical roller clutch consists of inner and outer races, rollers, and springs. The clutch performs its holding function when the rollers become wedged between the inner and outer races.

Sprag-Type

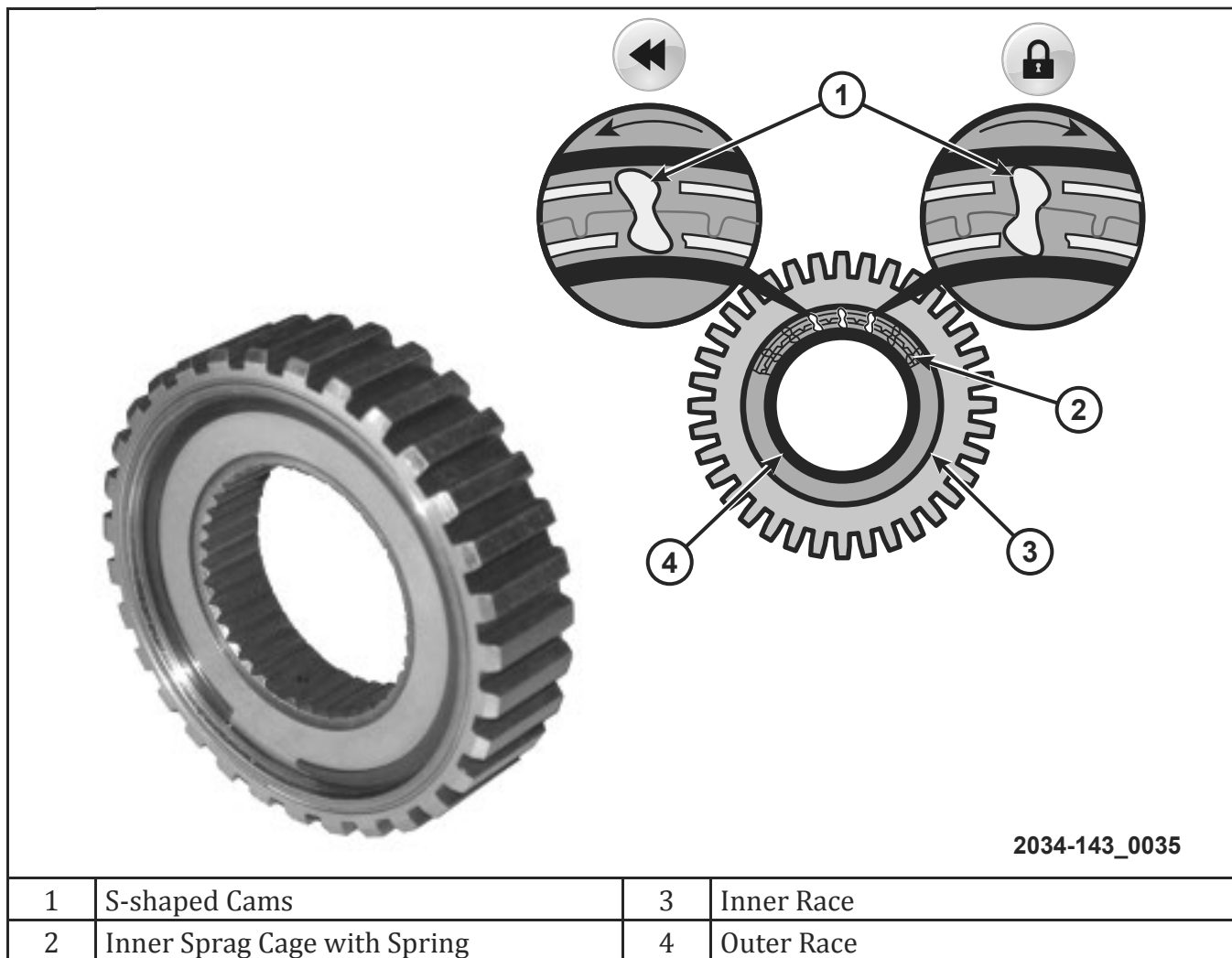

Figure 104 Sprag-type Overrunning Clutch

Another type of overrunning clutch is known as the sprag clutch. This type of clutch uses small metal pieces (known as sprags) instead of rollers to perform the holding action.

The overrunning clutch works by preventing rotation of the planetary gearset members in one direction. In one example, the outer race is attached to transmission case, and the inner race is attached to the planetary gearset member. When turned in one direction, the clutch rotates freely and allows attached members to rotate freely. When turned in the opposite direction, the clutch locks up and acts as a holding member. Overrunning clutches may be used as holding or driving members.

DOG CLUTCHES

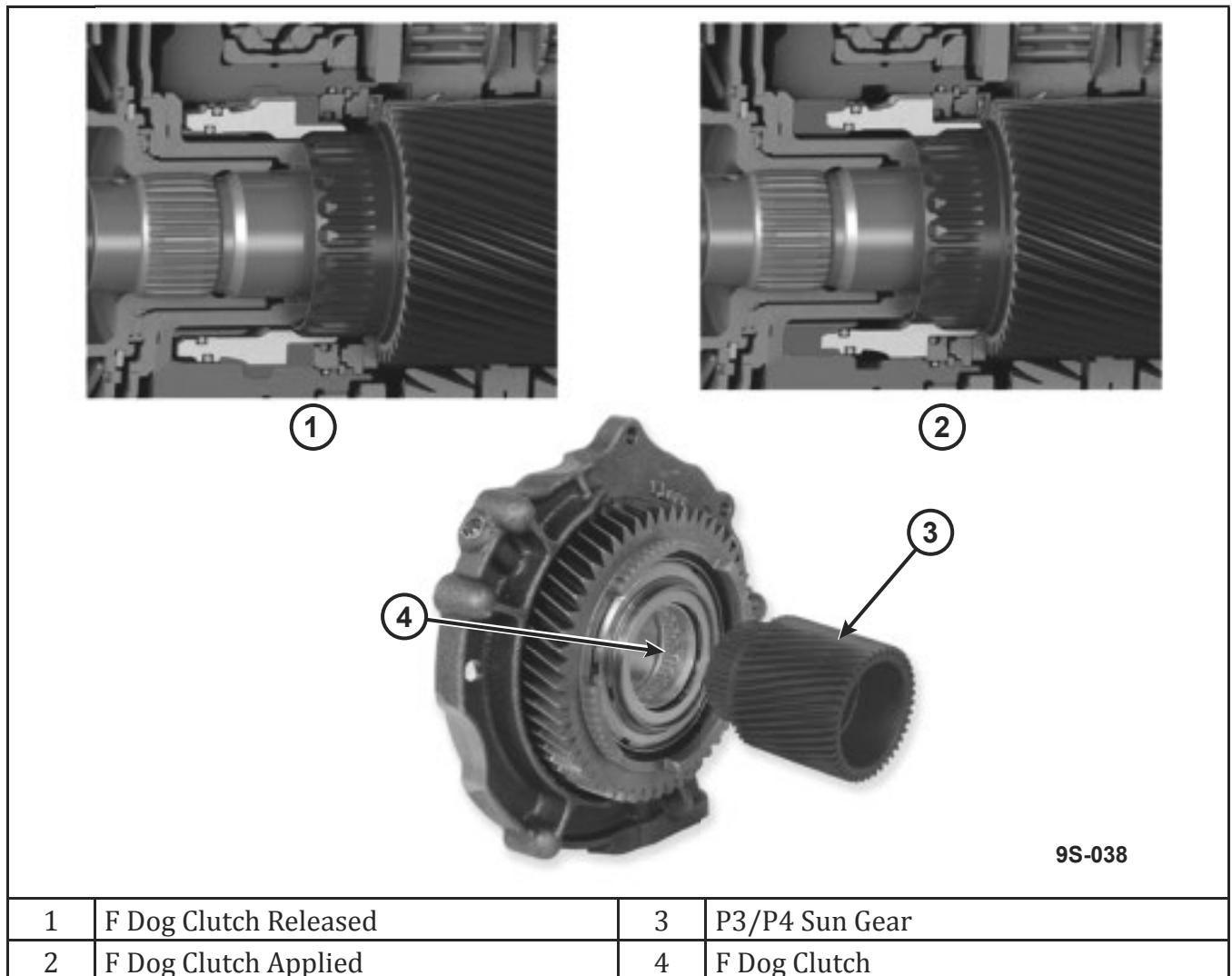

Figure 105 F Dog Clutch

Dog clutches do not have disc-style clutch packs that can provide slip to match component speed. The dog clutches in the 948TE cannot be applied during downshifts without consideration for speed differences between the splined components. If the dog clutch speed is different than the component to which it is engaging, noise and damage to the transmission occurs. The transmission control module (TCM) can send a torque increase or decrease request to the powertrain control module (PCM) over the controller area network-C (CAN-C) to allow speed matching.

Clutch Elements

CLUTCH LUBRICATION

Lubrication Passages

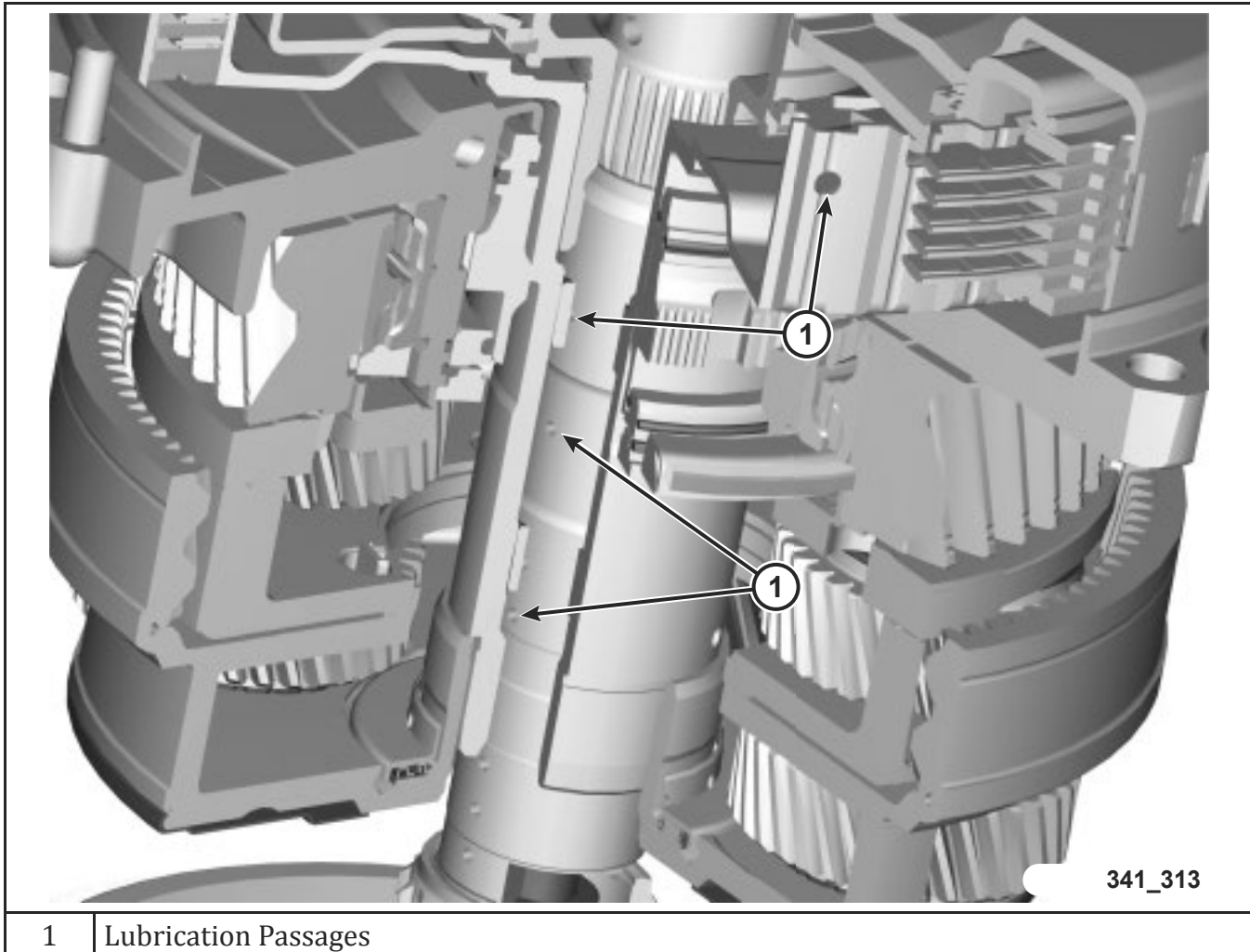

Figure 106 Clutch Lubrication Passages

The hydraulic circuits that supply lubrication to the gearset components also feed lubrication to the clutch elements. This lubrication is especially important for multi-disc clutches because they are designed to slip at times during operation. The lubrication to the multi-disc clutch plates provides two functions: reduce friction to allow slip, and transfer heat from the clutch. Insufficient lubrication can rapidly cause clutch element failure.

In general, the fluid is fed to the centerline of the rotating assembly and then migrates outward. Multi-disc clutches have holes in the hubs to allow the fluid to enter the clutch pack. The friction material also has cut channels in the surface that are designed to distribute the fluid on the material and also allow the fluid to escape as the clutch is applied.

NOISE

Clutch Noise

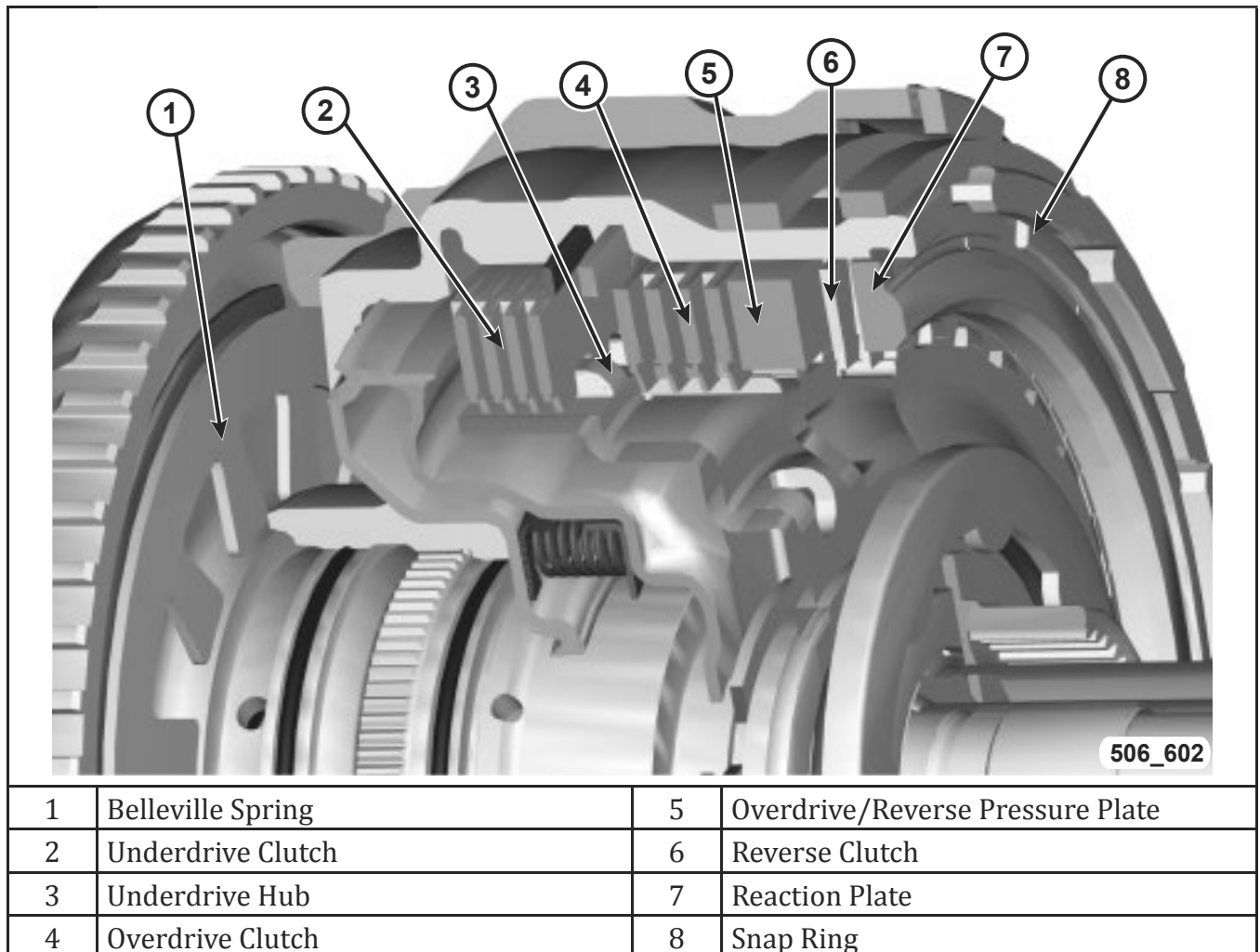

Figure 107 Clutch Components

Clutch noise is usually related to what gear is applied. Because of typical automatic transmission operation, it is necessary to have a clutch application chart to isolate the root cause of a clutch noise and what clutch it is related to. In many cases, two or more clutches can be identified to be applied for a specific gear.

Noise can be caused by the following clutch types:

- Multi-plate
- Overrunning
- Dog

A multi-plate clutch may make a hiss or squeal (metal to metal) noise on apply or release. This is usually due to excessive slippage of the clutch before it fully applies, or if it is releasing slowly.

Clutch Elements

Overrunning clutches may squeal, chatter, or clunk on apply. Regardless of roller or sprag type, this is usually due to pits or imperfections in the inner and outer races. Worn rollers or sprags can also cause an overrunning clutch to slip or apply erratically, causing a clunk, or multiple clunks when attempting to hold.

Dog clutches may grind or clunk on apply if engagement is slow. Dog clutches use gears, so they are usually in or out of engagement. If a non-dog clutch release is slow and speed matching, which is crucial for dog clutch operation, is not accomplished, a noise may occur, but not actually be caused by the noisy dog clutch.

DEMONSTRATION 6 SOLENOID APPLICATION CHART

Instructions: In this demonstration, the instructor will ensure that all students understand how to use the solenoid application chart for diagnostics. In order to perform this demonstration, we will be diagnosing a 3-4 shift problem where the transmission will not shift to 4th gear. The instructor will help navigate through the questions and provide any required information.

62TE Solenoid Application Chart							
Gear	Ratio	Solenoid Application					
		U D	D C	L R	O D	L C	D C
1st Gear	4.12:1		O	O		O*	
2nd Gear	2.84:1		O	O			O
3rd Gear**	2.28:1					O*	
4th Gear (P)	1.57:1						O
4th Gear	1.45:1		O		O	O*	
5th Gear	1:1		O		O		O
6th Gear	0.68:1	O			O		O
Reverse	3.21:1					O	
** = Default Gear (P) = Prime O = Energized O* = Applied During Coast Only							

1. Which solenoids are associated with 4th gear?

2. Which solenoids turn on or off to shift from 3rd to 4th gear?

3. How do you determine if a solenoid is normally-open?

Solenoid Application Chart

4. How do you determine if a solenoid is normally-closed?

5. Which clutch solenoids on the 3-4 shift are normally-open solenoids?

6. Which clutch solenoids on the 3-4 shift are normally-closed solenoids?

7. Are any of the 4th gear solenoids working properly in other gears?

8. Which solenoid needs further investigation?

9. Is a solenoid faulty if the clutch does not apply?



ACTIVITY 16 CLUTCH HYDRAULIC DIAGNOSIS

Assemble the Input Housing

1. Install the input clutch assembly to the Input Clutch Pressure Fixture, 8391.



Clutch Hydraulic Diagnosis

2. Ensure that the number two thrust bearing (2) is installed in the center of the input housing clutch hub.

NOTE: The number two thrust bearing is a snap fit into the clutch hub. There are five tabs with dimples that can be pressed in by hand.

3. Install the underdrive shaft assembly.
4. Rotate and wiggle the underdrive hub to line up the clutch splines.
5. Ensure that the clutch hub is seated all the way against the number two thrust bearing.
6. Install the number three thrust washer (1) to the underdrive hub assembly (3). Ensure the five tabs are seated properly.

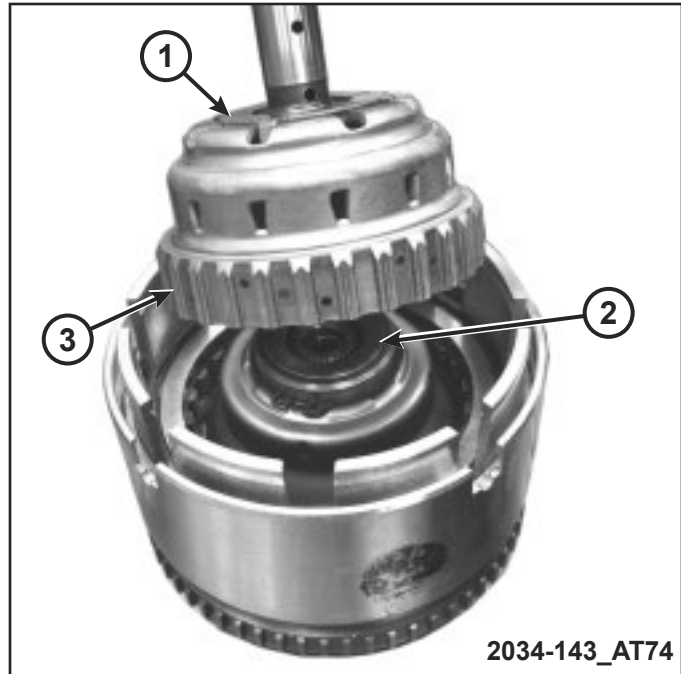

7. Install the number three thrust plate (1) by aligning the three tabs with the holes on the top of the overdrive shaft assembly (2).
8. Use transmission assembly gel to retain the thrust plate to the overdrive hub.
9. Install the overdrive hub assembly.
 - a. What do you notice about this hub assembly?

- b. What does this mean for order of assembly?

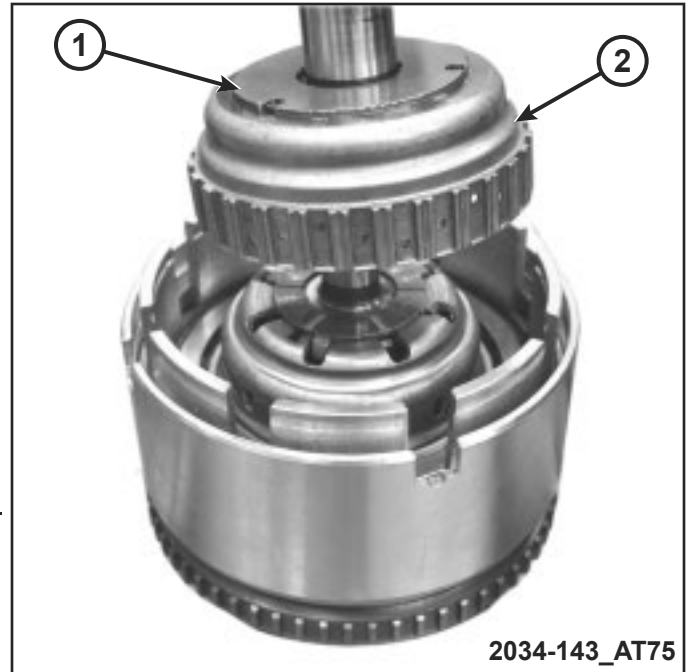

Clutch Hydraulic Diagnosis

10. Install the OD clutch pack.
11. Install four frictions and three steels. Start with a friction and end with a friction.



12. Install the OD pressure plate waved snap ring into the bottom of the outer grooves.



13. Install the OD/reverse pressure plate with the large step facing down, towards the OD clutch pack.



14. Install the OD pressure plate flat snap ring around the outside edge.
15. Push down on the OD pressure plate to install the snap ring into the groove.



Clutch Hydraulic Diagnosis

16. Install the reverse clutch pack, which consists of two frictions and one steel. Start with a friction disc and end with a friction disc.



17. Install the reverse clutch reaction plate with the flat side down, towards the reverse clutch.



18. Tap down the reaction plate to allow installation of the reverse clutch snap ring. When it is down far enough, you can see the groove completely.
19. Install the reverse clutch snap ring.
 - a. What would the symptom be if this snap ring fails?



Clutch Hydraulic Diagnosis

20. Use two screwdrivers at points (1) and (2) to gently pry up on the reverse reaction plate and seat it against the top snap ring. This loosens up the reverse clutch.
21. Install the reverse clutch splines of the front sun gear assembly into the reverse clutch. Turn and shake lightly to get both reverse friction plates lined up, then remove.

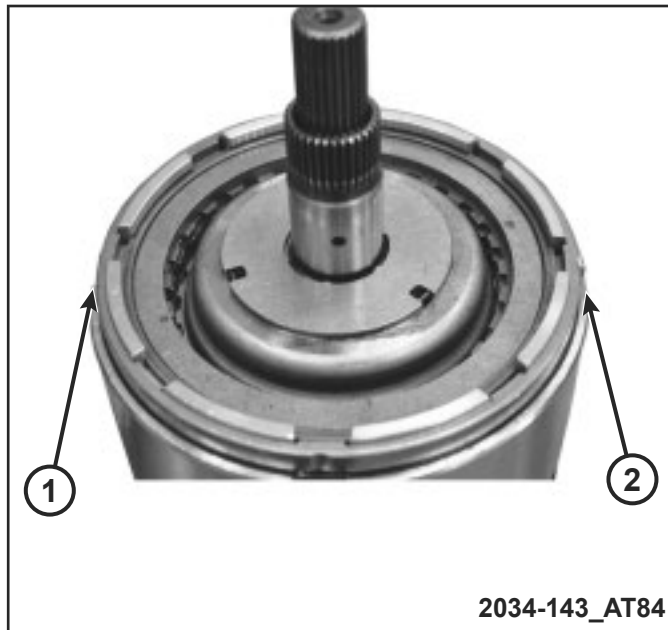

Instructions: A 62TE will not move in Drive, but it will move in Reverse.. Use the chart below to answer the following questions.

62TE Clutch Application Chart															
Gear	Ratio	Main Line Clutches					Compounder			Solenoid Application					
		UD	OD	R	2/4	L/R	LC	DC	ORC	U D	D C	L R	O D	L C	D C
1st Gear	4.12:1	X				X	X*		H		O	O		O*	
2nd Gear	2.84:1	X				X		X			O	O			O
3rd Gear**	2.28:1	X			X		X*		H					O*	
4th Gear (P)	1.57:1	X			X			X							O
4th Gear	1.45:1	X	X				X*		H		O		O	O*	
5th Gear	1:1	X	X					X			O		O		O
6th Gear	0.68:1		X		X			X		O			O		O
Reverse	3.21:1			X		X	X							O	

X = Applied ** = Default Gear
 O = Energized (P) = Prime
 H = Holding O* X* = Applied During Coast Only

22. Which clutch is this symptom associated with?

23. Which solenoid or solenoids are associated with this clutch?

24. Is the associated clutch solenoid a normally-open solenoid?

Clutch Hydraulic Diagnosis

25. Where are the clutch solenoids located in this transmission, and how did you determine that?
-

Instructions: Use the hydraulic schematics in service information to answer the following questions.

26. Are any valves directly involved in the application of this clutch?
-

27. Are any check balls directly involved in the application of this clutch and where are they located?
-

28. Is there an accumulator directly involved in the application of this clutch and where is it located?
-

29. Where is the clutch located in the transmission assembly?
-

30. Can you verify clutch operation with the transmission in the vehicle and how?
-

31. Can you verify clutch operation with the input clutch assembly out of the case and how?
-



ACTIVITY 17 CLUTCH MECHANICAL DIAGNOSIS

Instructions: A 62TE will not move in Drive, but it will move in Reverse.. Using the chart below, answer the following questions.

62TE Clutch Application Chart															
Gear	Ratio	Main Line Clutches					Compounder			Solenoid Application					
		UD	OD	R	2/4	L/R	LC	DC	ORC	U D	D C	L R	O D	L C	D C
1st Gear	4.12:1	X				X	X*		H		O	O		O*	
2nd Gear	2.84:1	X				X		X			O	O			O
3rd Gear**	2.28:1	X			X		X*		H					O*	
4th Gear (P)	1.57:1	X			X			X							O
4th Gear	1.45:1	X	X				X*		H		O		O	O*	
5th Gear	1:1	X	X					X			O		O		O
6th Gear	0.68:1		X		X			X		O			O		O
Reverse	3.21:1			X		X	X							O	
		X = Applied		** = Default Gear											
		O = Energized		(P) = Prime											
		H = Holding		O* X* = Applied During Coast Only											

- Which clutch is this symptom associated with?

- The input clutch assembly is removed from the transmission and is placed into the air check tool. The suspect clutch passes the air check test. When the suspect clutch pack clearance is measured, it is found to be excessive. What could be the mechanical cause of this clutch slipping?



ACTIVITY 18 CLUTCH NOISE DIAGNOSIS

Instructions: A vehicle equipped with a 948TE is brought into service with a concern of a noise during normal driving. Upon test driving the vehicle, the technician discovers that the grinding noise occurs during the 5-4 downshift. Use the 948TE clutch application chart to determine what clutches are related to the concern, then answer the following questions.

948TE Clutch Application Chart

Gear	Ratio	A Dog	B	C	D	E	F Dog
		Driving	Driving	Braking	Braking	Driving	Braking
P/N					X		X
R	3.80		X		X		X
1	4.70	X			X		X
2	2.84	X		X			X
3	1.91	X	X				X
4	1.38	X				X	X
5	1.00	X	X			X	
6	0.81	X		X		X	
7	0.70	X			X	X	
8	0.58			X	X	X	
9	0.48		X		X	X	
4 Default*						X	X
Rock Cycle**	Braking			X	X		X
	N-1 Transition	Delayed Apply			X	Slipping	X
	N-2 Transition	Delayed Apply		Applied	Released	Slipping	X
* Default is only available on park-by-cable systems.							
** These modes are only used during a R-D rocking cycle							
506_007							

- Which clutch is this symptom associated with?

- If the hydraulic pressure to the clutch was reduced, could this cause the symptom?

Clutch Noise Diagnosis

3. If the gear teeth were worn, could this cause the concern?

4. Identify the area of concern on the graphic below placing an X next to the number in the table below.

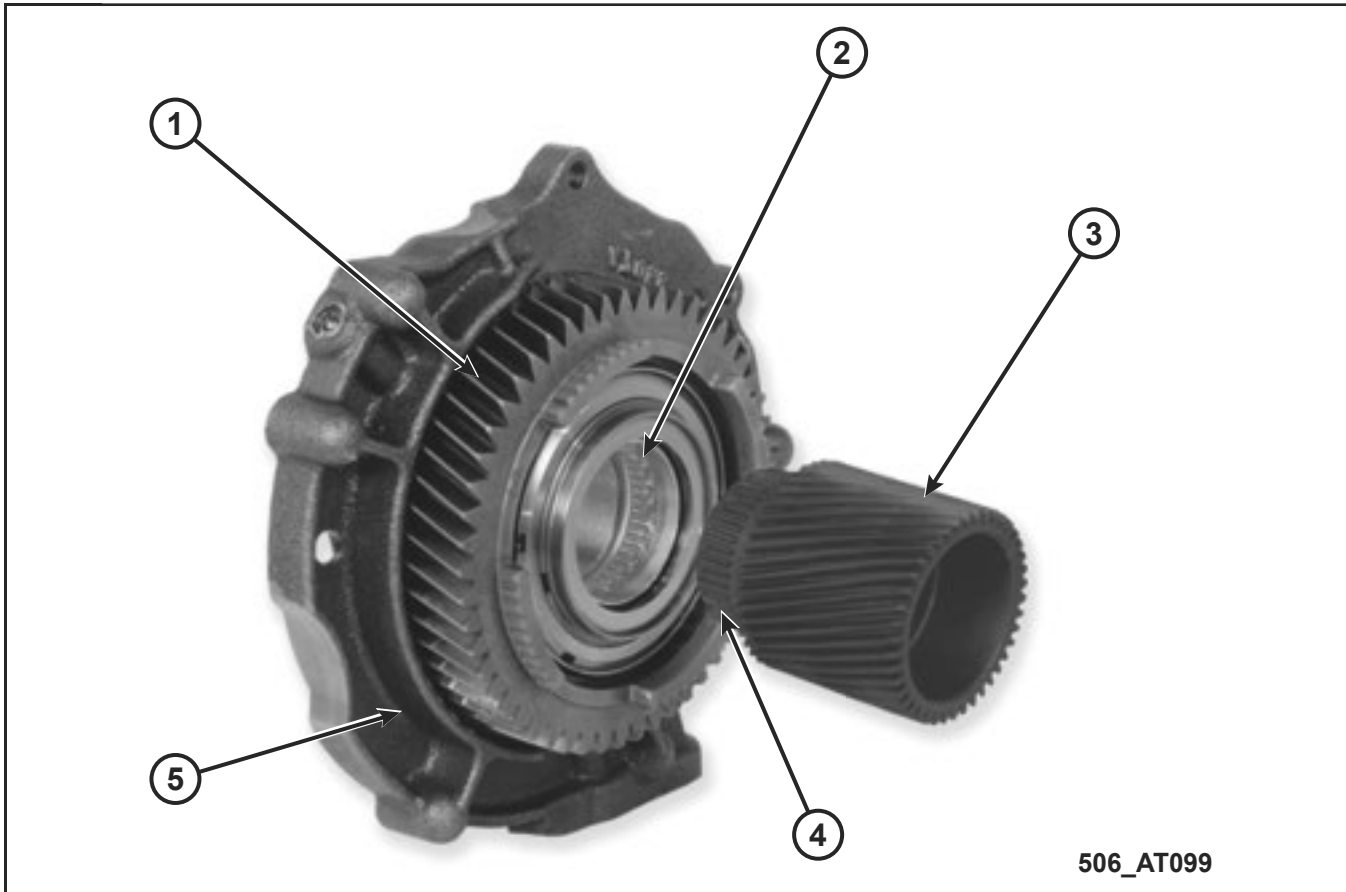

1 Output Gear	4 Sun Gear Splines
2 Dog Clutch Splines	5 Sun Gear Support
3 Sun Gear	



Notes: _____

ACTIVITY 19 TRANSMISSION ASSEMBLY

Instructions: Assemble the transmission using the instructions below.

NOTE: This is NOT a service procedure. This procedure was designed for training purposes only. This is a set of instructions to guide you through the in-class activity. Always refer to service information when servicing a vehicle.

1. Install the rear carrier assembly into the transaxle case.



Transmission Assembly

2. Install the bearing shim.
3. Install the output transfer gear and bearing assembly using Installer, 6261.

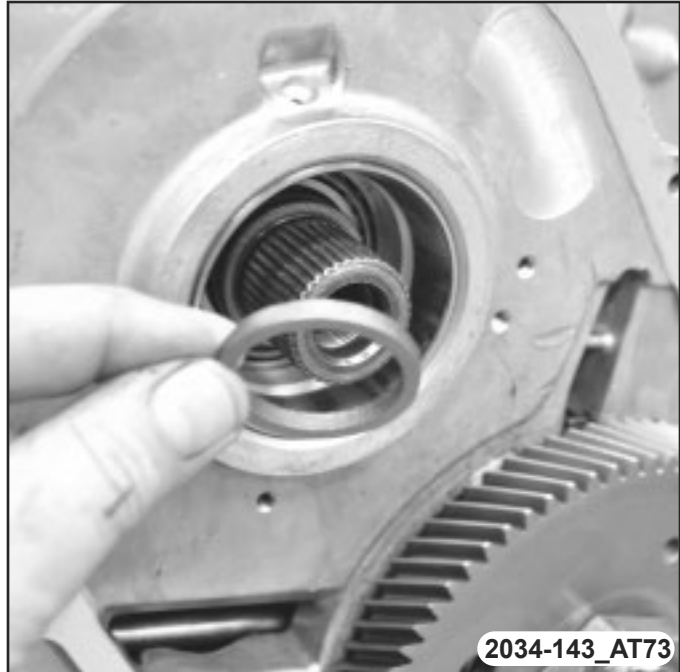

4. Install the output transfer gear retaining bolt and washer.
 5. Install Gear Holder, 9739, onto the output transfer gear.
 6. Tighten the output transfer gear retaining bolt.
 - a. What is the torque specification for this bolt?
-

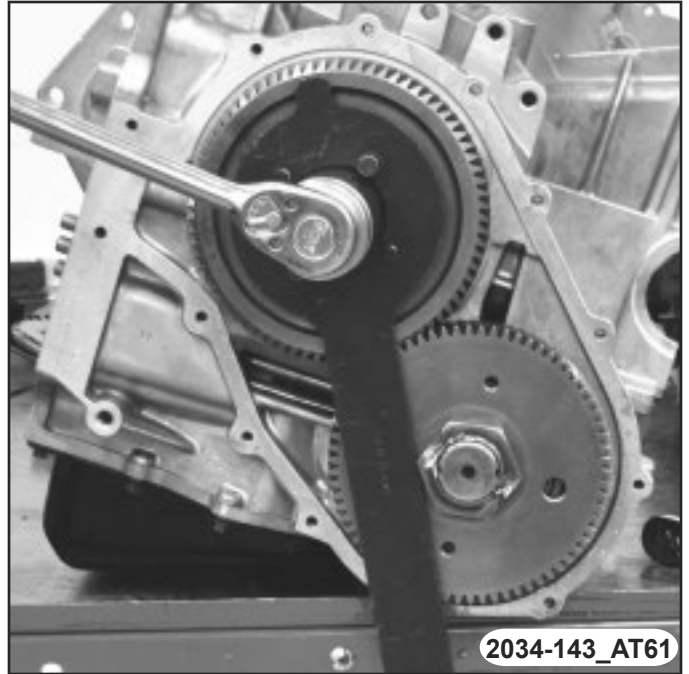

Transmission Assembly

7. Install the output gear stirrup with the serrated side out, and install the retaining strap.
 8. Install the strap bolts, but do not tighten.
 9. Rotate the stirrup clockwise against flats of the retaining bolt and tighten the stirrup strap bolts.
 - a. If this stirrup fails, what would be the symptom?
-
-

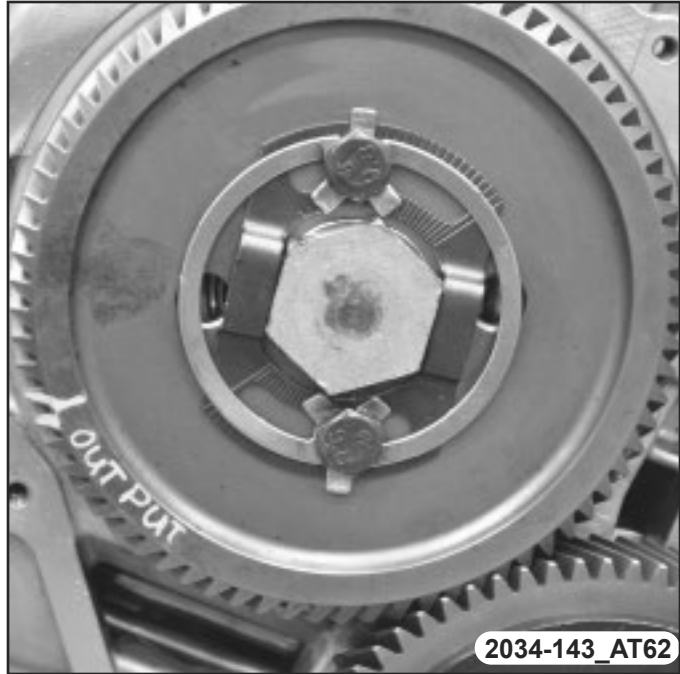

10. Install the oil baffle.
- a. What do you think the symptom would be if the oil baffle was not installed?
-

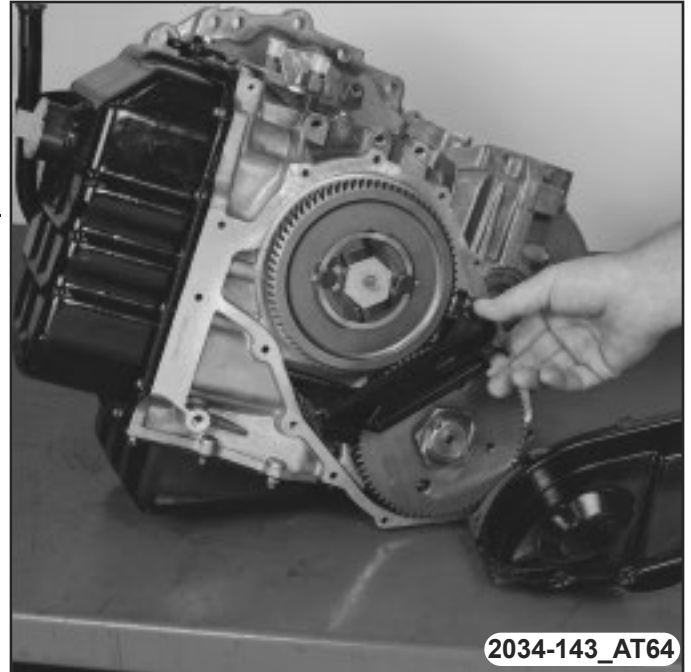

11. Install the transfer gear cover.
- a. What is the bolt torque specification?
-

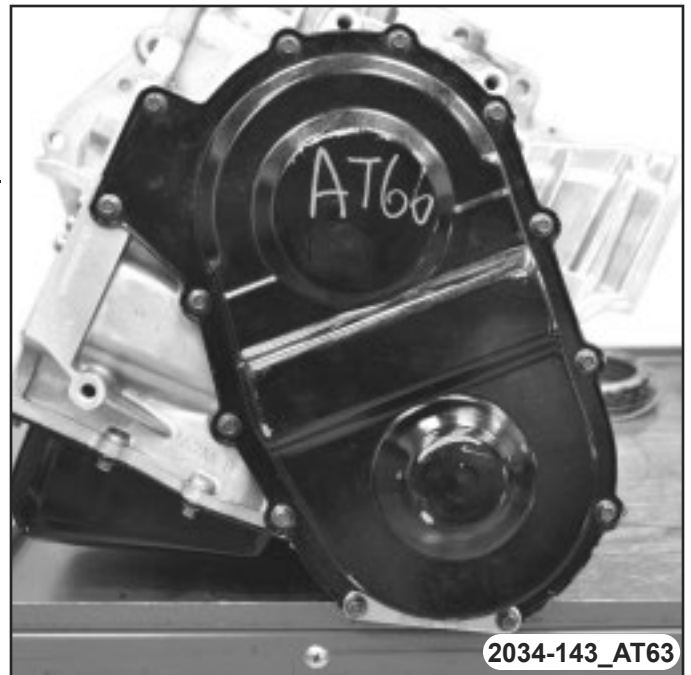

Transmission Assembly

Assemble the Main Line

12. Install the low/reverse clutch pack. Leave the uppermost friction disc out until after the snap ring is installed.

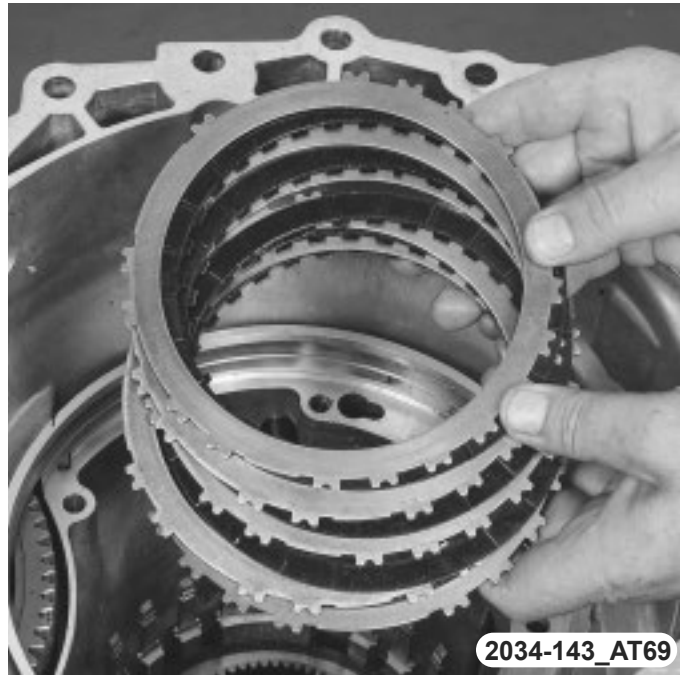

13. Install the low/reverse reaction plate flat snap ring. Do not scratch the clutch plate.
- a. What would the symptom be if this snap ring fails?



Transmission Assembly

14. Install the remaining low/reverse clutch disc.
15. Install the low/reverse reaction plate, bevel or lug side facing up.



16. Install the tapered snap ring with the tapered side facing up.
17. The opening of the snap ring should be between the 9 and 10 o'clock positions when installed.
 - a. What would the symptom be if this snap ring fails?

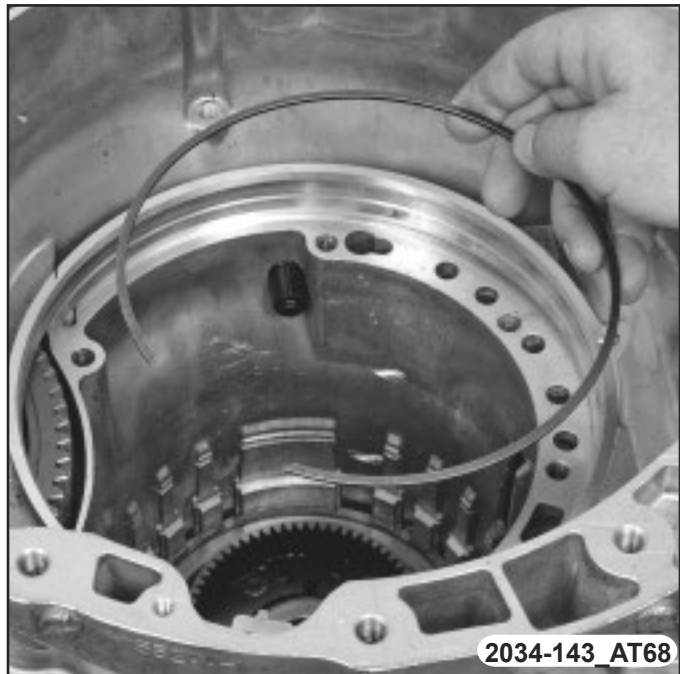

18. Install the 2/4 clutch pack.

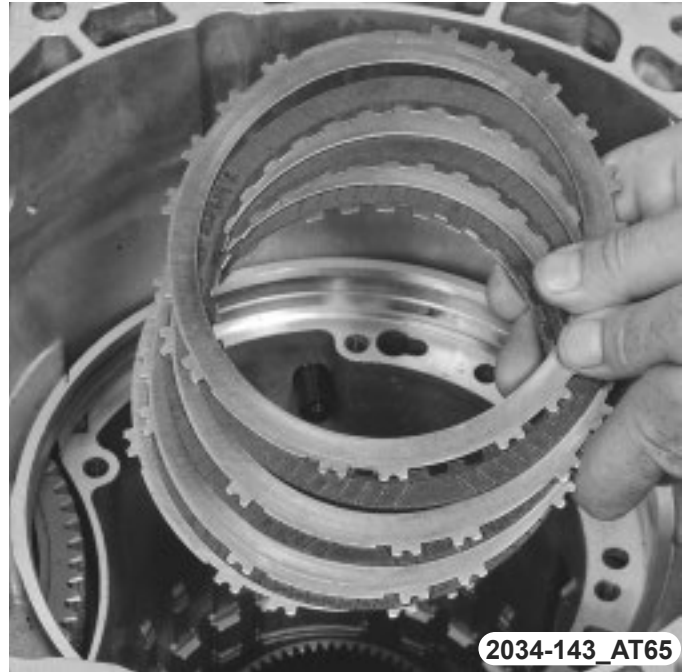

19. Orient the 2/4 clutch return spring to the retainer.
- a. How does the 2/4 return spring fit into the 2/4 piston?
-
-

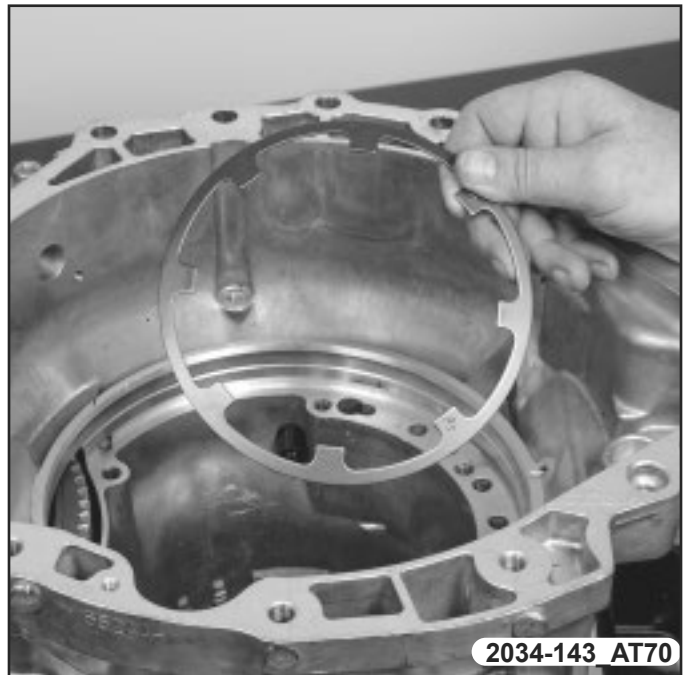

Transmission Assembly

20. Install the 2/4 clutch retainer to the transaxle.
- a. Why is there a hole in the 2/4 piston retainer?
-
-

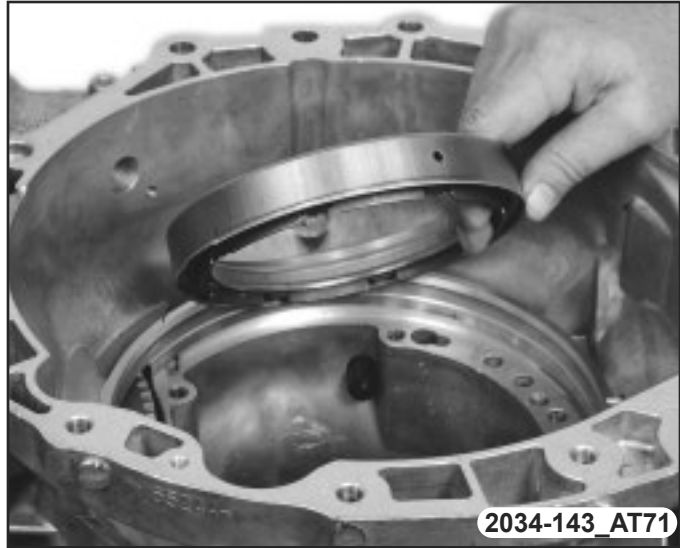

21. Using Spring Compressor, 5058A, compress the 2/4 clutch return spring just past the snap ring groove.
22. Install the snap ring.
- a. What would the symptom be if this snap ring fails?
-

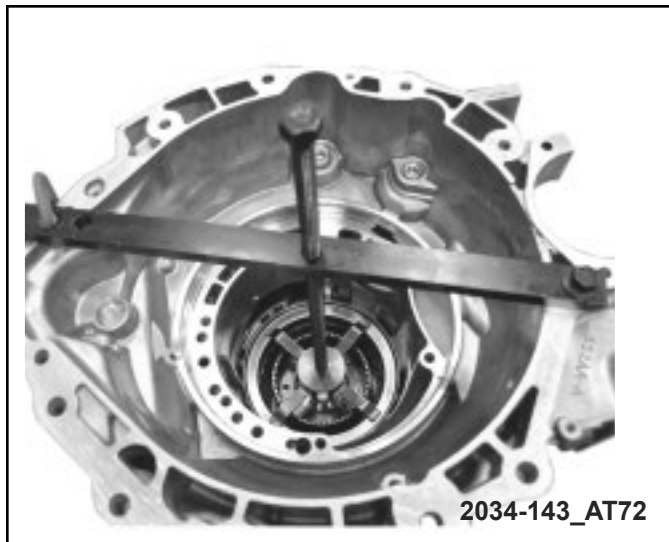

23. Install the rear sun gear and the number seven thrust bearing.
24. The number seven thrust bearing goes between the rear sun gear and the rear carrier assembly.

NOTE: The number seven thrust bearing has three anti-reversal tabs and is common with the number five thrust bearing. The orientation should allow the bearing to seat flat against the rear sun gear. A small amount of transmission assembly gel can be used to hold the bearing to the rear sun gear.



Transmission Assembly

Assemble the Main Line

25. Install the front carrier/rear annulus assembly and number six thrust bearing.
26. The number six thrust bearing is secured to the carrier annulus assembly using transmission assembly gel.



27. Install the front sun gear assembly (1) and number four thrust washer (2).
28. Rotate and wiggle the front sun gear assembly to line up the 2/4 clutch discs.

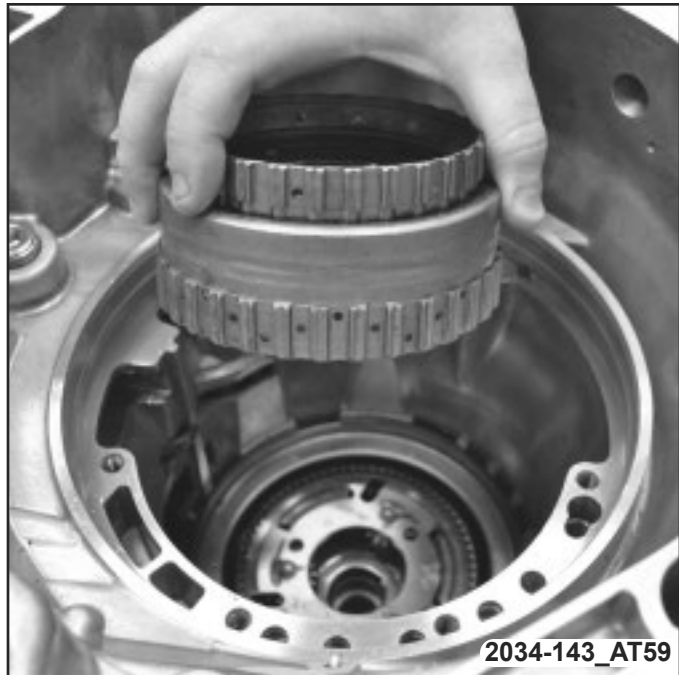

- 29. Ensure that the reverse clutch discs are lined up with the front sun gear hub splines.
- 30. Install the input housing assembly.
- 31. To help line up the reverse clutch discs, rotate the housing back and forth while wiggling.



- 32. When the input housing and front sun gear hub are lined up, the speed sensor tone ring is centered when viewed through the speed sensor hole in the case.
 - a. What is another way to know if the input housing is fully seated?

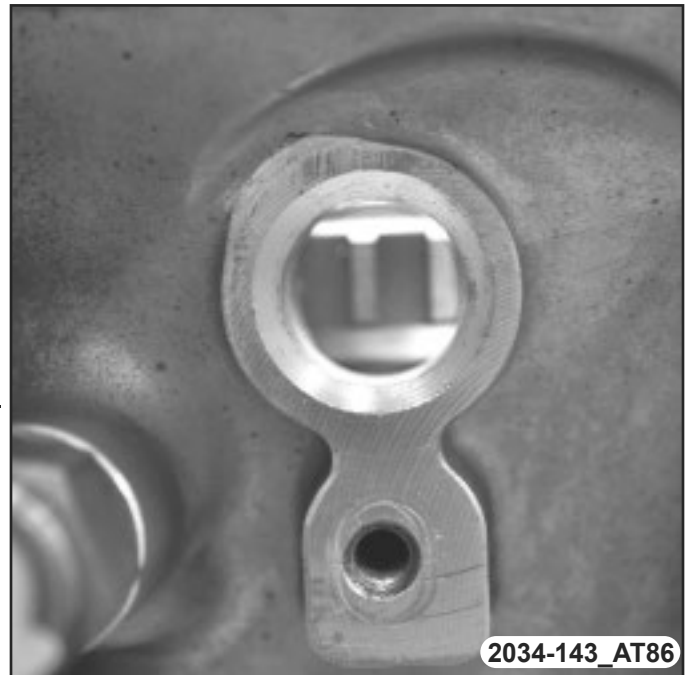

Transmission Assembly

33. Install the cooler pressure bypass valve with the O-ring end towards rear of case.



34. Install the selective thrust plate and the number one thrust bearing with the tanged side out.

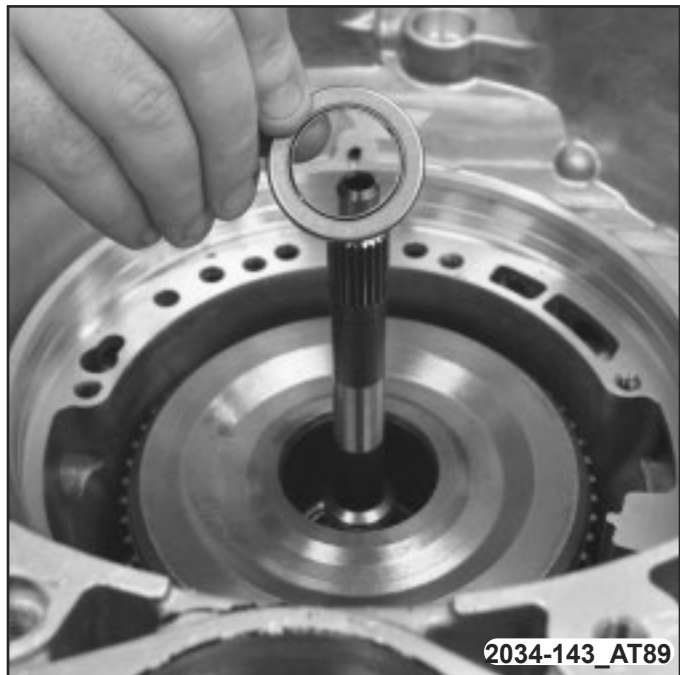

35. Install the oil pump gasket.

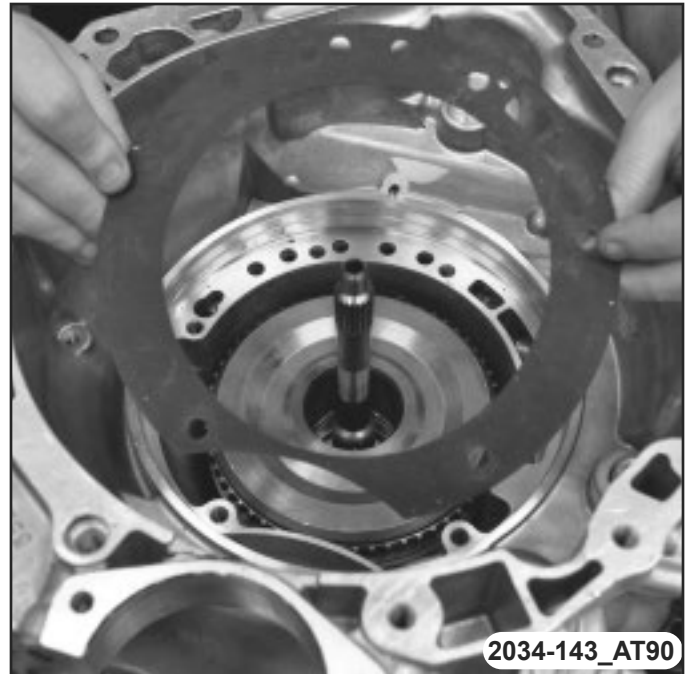

36. Install the oil pump assembly.
37. Torque the oil pump bolts.
a. What is the torque specification?
-



Transmission Assembly

Install the Valve Body Assembly

38. Install all six accumulators and cushion springs into the case.
- a. Are there any differences in the six assemblies on this transmission?
-
- b. Would shifts be affected if the accumulator springs were different and they were incorrectly installed?
-
39. Ensure the oil transfer tubes are installed into the case and compounder.

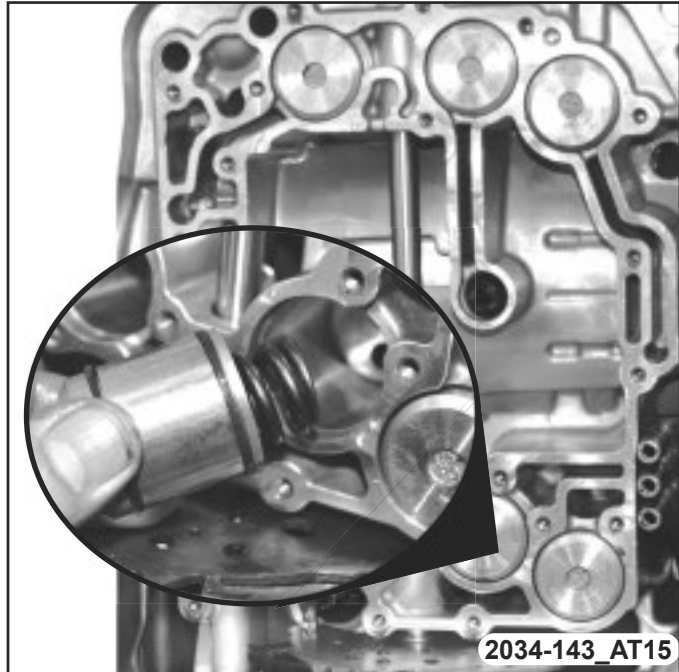

40. Install the 2/4 clutch oil supply seal into the case.

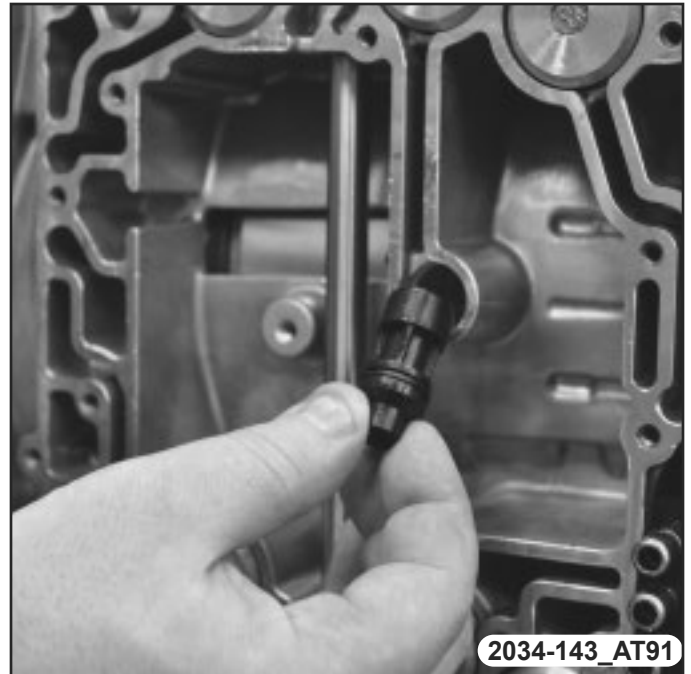

Transmission Assembly

41. Install the Air Test Plate Tool, 9741.
 42. Air test the main line clutches.
 - c. Was there any difference between the clutch air check results between disassembly and assembly?
-

43. What is the purpose of clutch air checking during assembly?
-
-

44. Remove clutch air test plate tool.

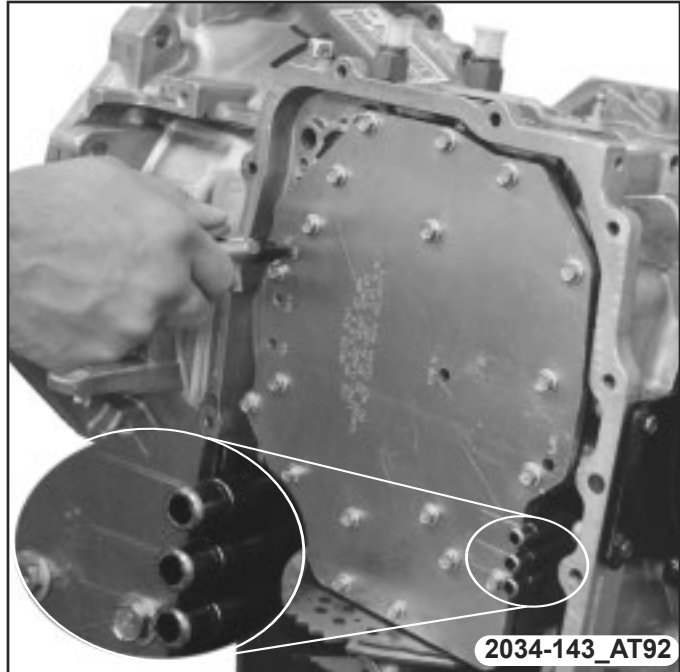

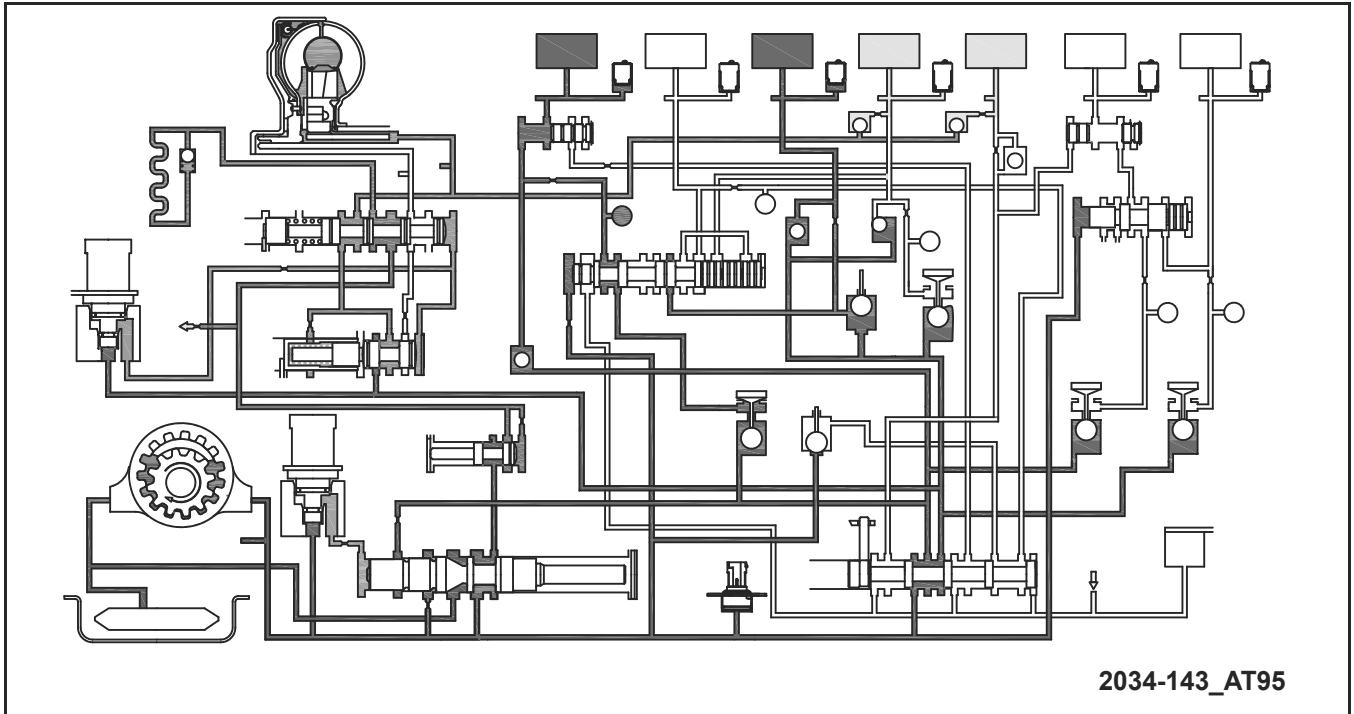

45. Circle the part of the hydraulic schematic that you just tested.
46. Install the valve body onto the oil transfer tubes and the manual valve at the rooster comb.

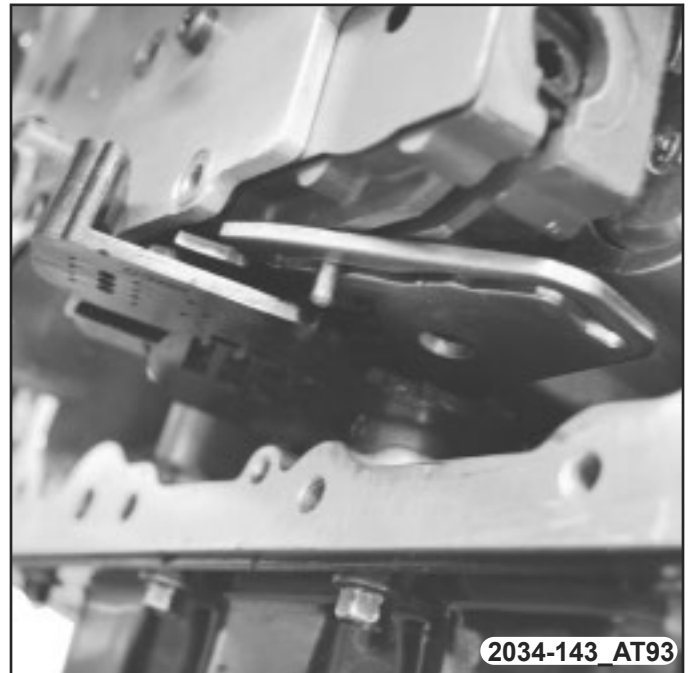

Transmission Assembly

47. Install the valve body bolts and tighten to 7 N•m (50 in.-lbs.).
48. Install the detent spring.
49. Install the bolt holding the detent spring and tighten to 7 N•m (50 in.-lbs.).



50. Install the electrical connector at the pressure transducer sensor (1) and at the range sensor (2).

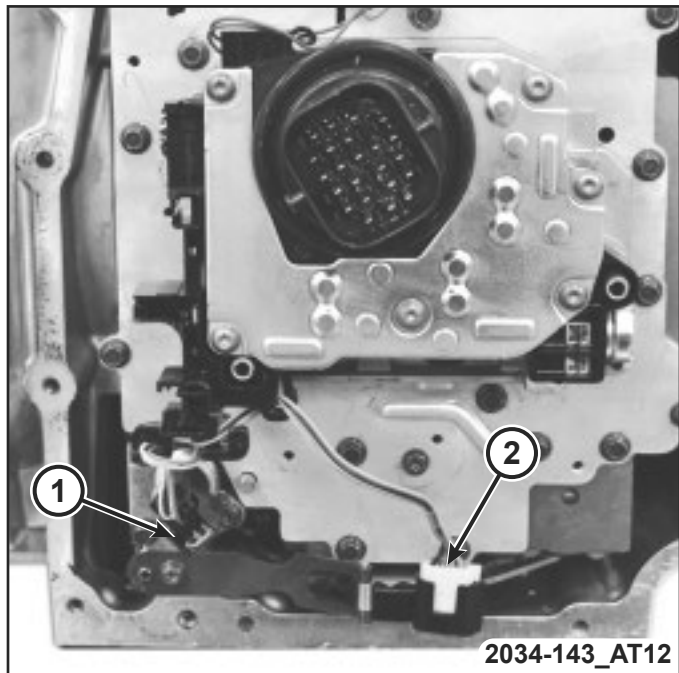

- 51. Install the valve body oil pan.
- 52. Install the valve body oil pan bolts (1) and tighten to 12 N•m (105 in.-lbs.).
- 53. Install the main line pressure tap plug (2).

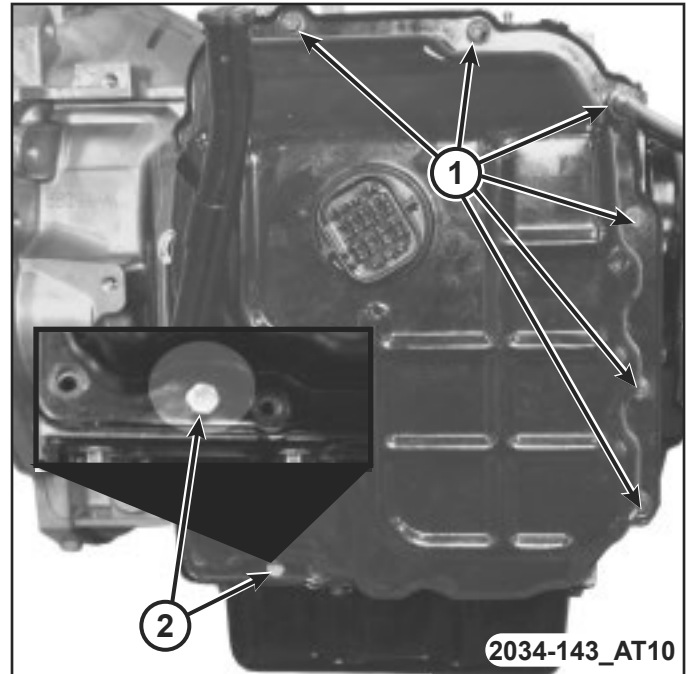

- 54. Install the speed sensors (1, 2, and 3) and tighten the bolts to 12 N•m (105 in.-lbs.).
 - a. From what component does the transfer speed sensor (2) get its reading?
-

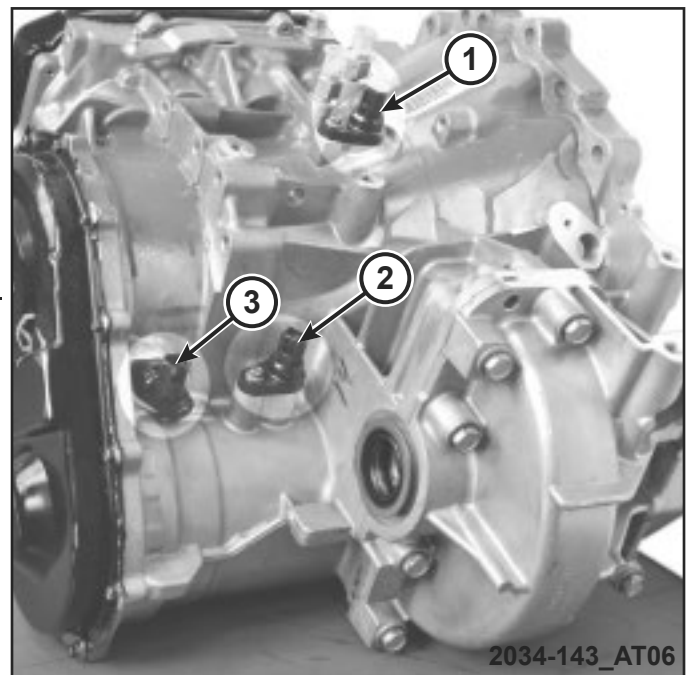

APPENDIX

BASIC HYDRAULIC CIRCUITS

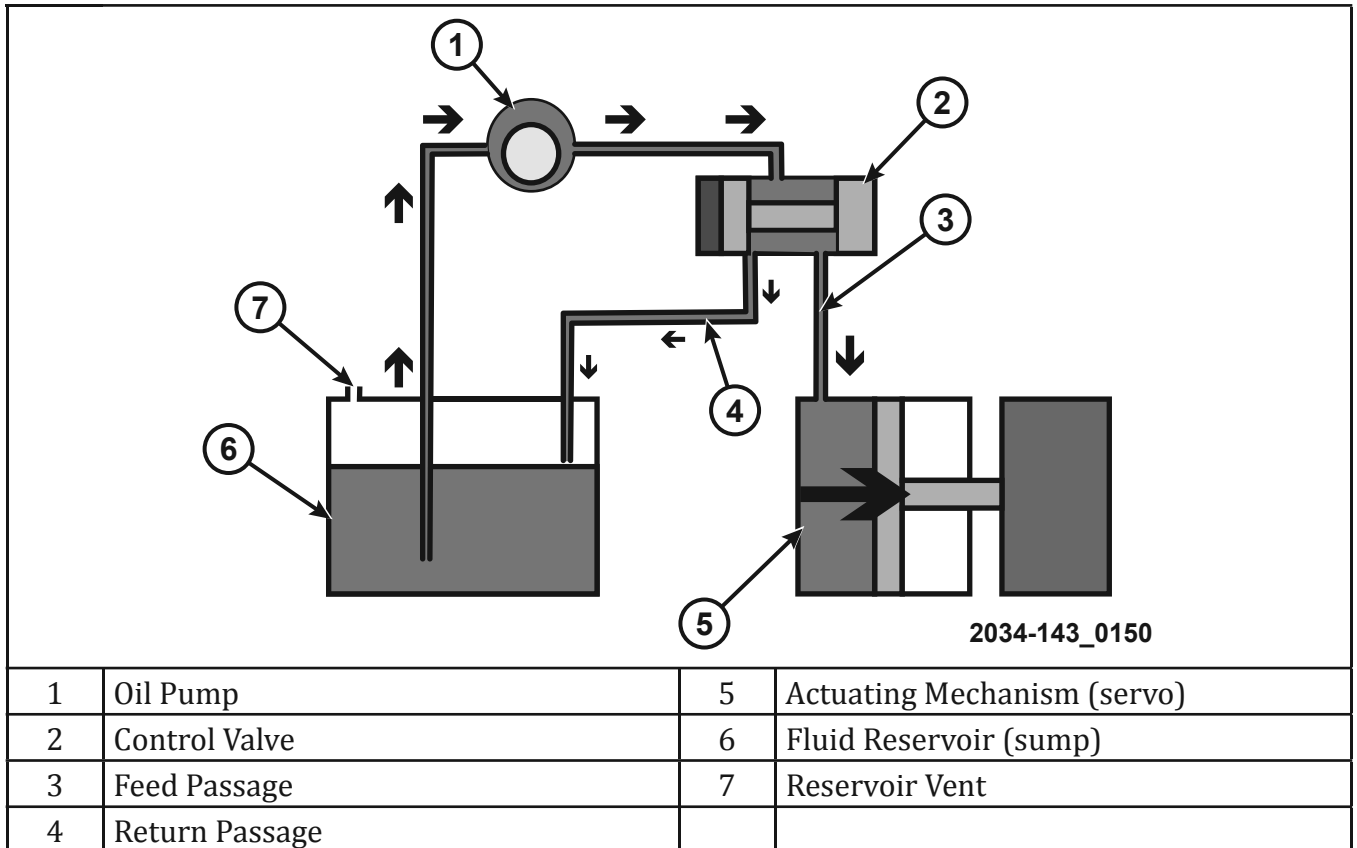

Figure 108 Basic Hydraulic Circuit

Today's automatic transmissions contain a complex maze of hydraulic circuits. To diagnose the automatic transmission's hydraulic system, a better understanding of how the basic hydraulic circuit works is needed.

The basic hydraulic circuit contains a pump, sealed hydraulic passages (lines or pipes), control valves, and an output device or actuator. The pump is used to maintain a continuous source of oil flow to move the oil through the system. The hydraulic passages carry the oil to the control valves. The control valves regulate the oil pressure and control the direction and flow of the oil to the actuator to do the work.

Oil Pump

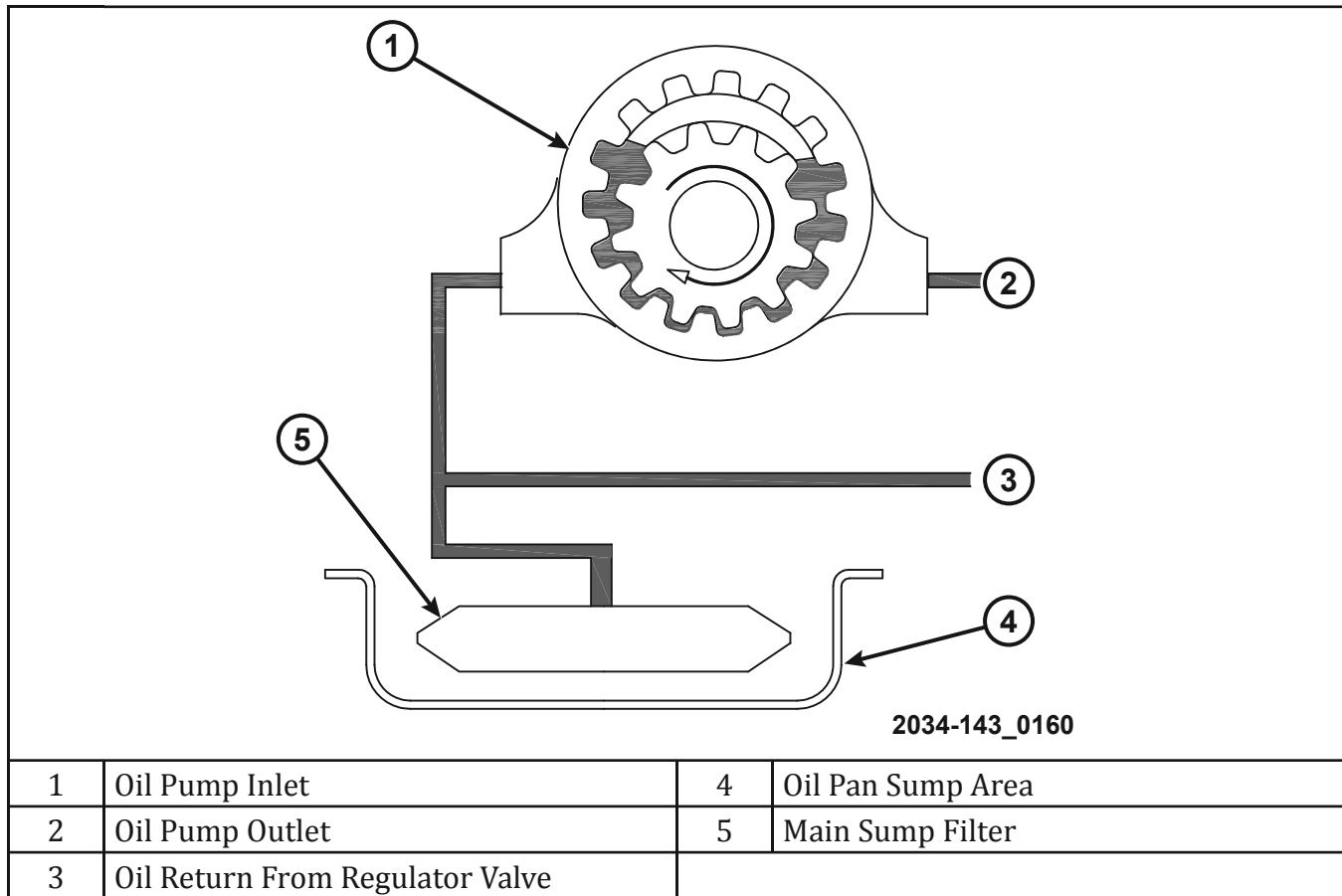

Figure 109 Oil Pump Operation

The rotating pump gears create a low-pressure area on the inlet side of the pump. Atmospheric pressure, entering through the transmission vent assembly, pushes the fluid through the filter and into the pump inlet. Fluid entering the pump passes between the teeth of the rotating gears. The area between the teeth of the rotating gears decreases, squeezing the fluid into the smaller discharged area on the outlet side of the pump. This resistance to fluid flow pressurizes the fluid as it enters the hydraulic system.

Types of Valves

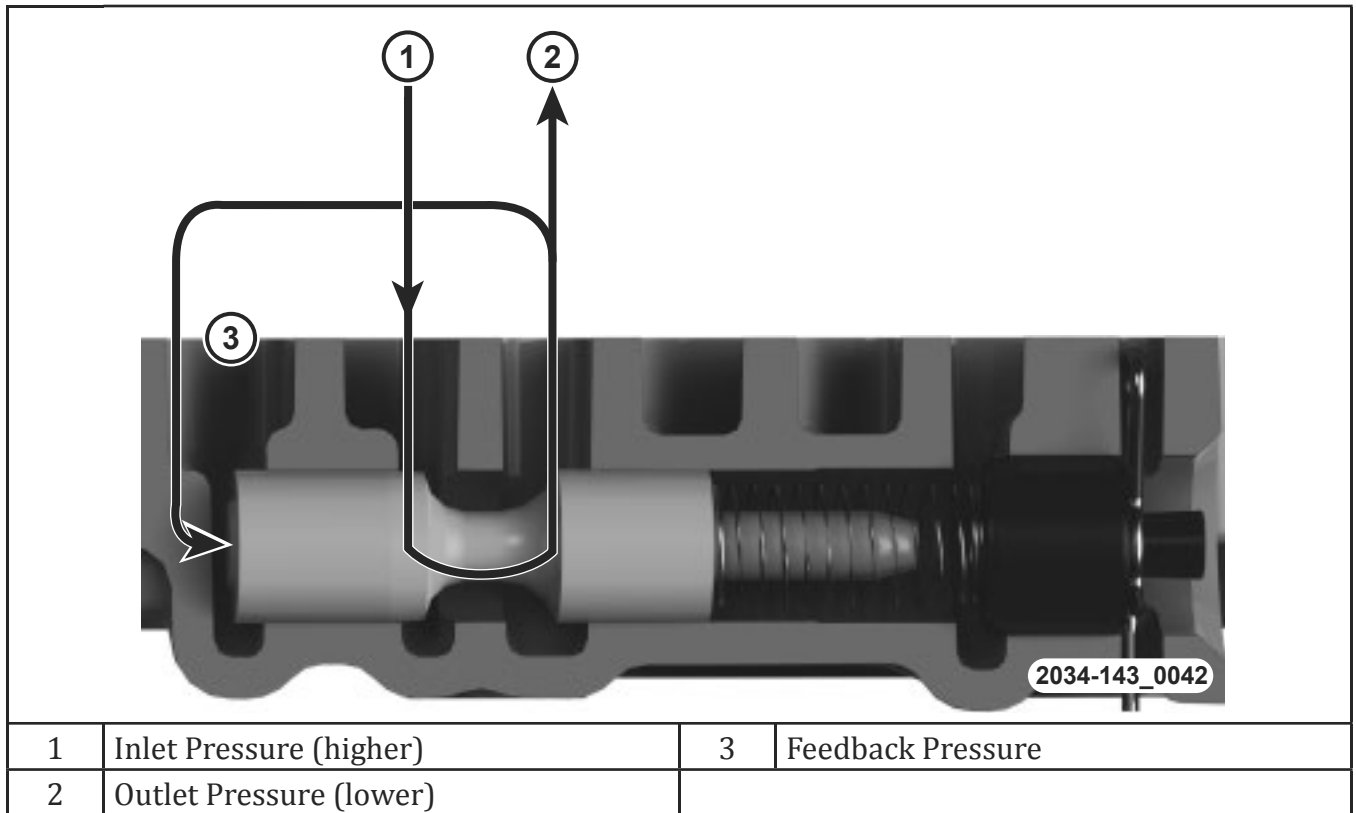

Figure 110 Pressure Reducing Valve

After the pump has started to move and compress the oil, the system needs some sort of control valve to direct and regulate the fluid. The pump will pump oil to its capacity all the time. It is up to the valves to regulate the flow and pressure in the system. The opposing forces that position a valve can be any of the following combinations:

- Hydraulic pressure vs. spring pressure
- Hydraulic pressure vs. hydraulic pressure
- Hydraulic pressure vs. spring tension assisted by hydraulic pressure

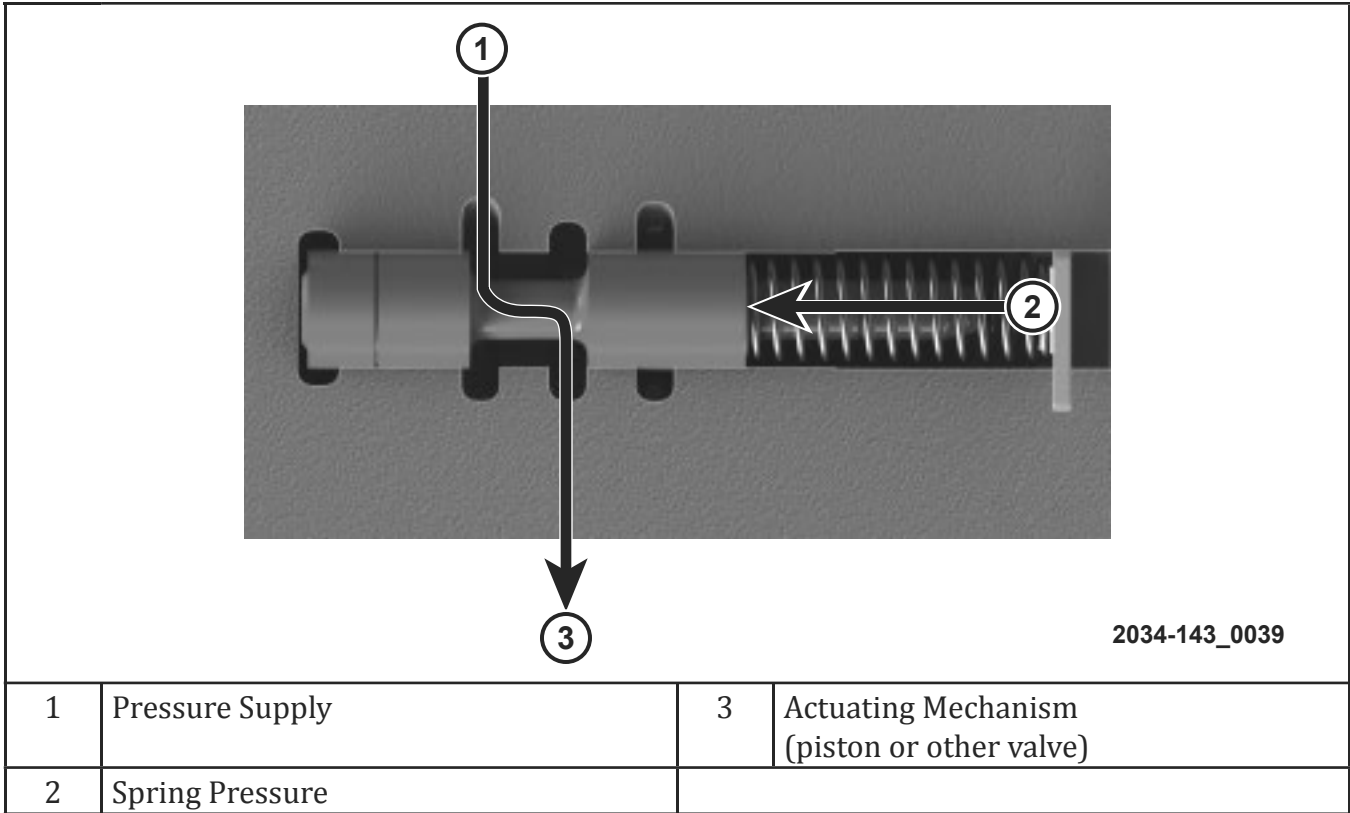

Figure 111 Balance Valve in the Rest Position

Most transmissions have hydraulic systems that use valves with a spool valve design. Each valve has a face on each of its ends and one or more valleys located between lands. A valve is positioned in its bore by opposing forces acting on its faces.

This balance valve connects two different oil passages and controls the oil flow between the two. The valve can move in one direction or the other in a bore, opening or closing another passage. The valve moves left or right, according to which force is greater.

When the spring force is greater than the hydraulic force, the valve is pushed to the left, closing the passage.

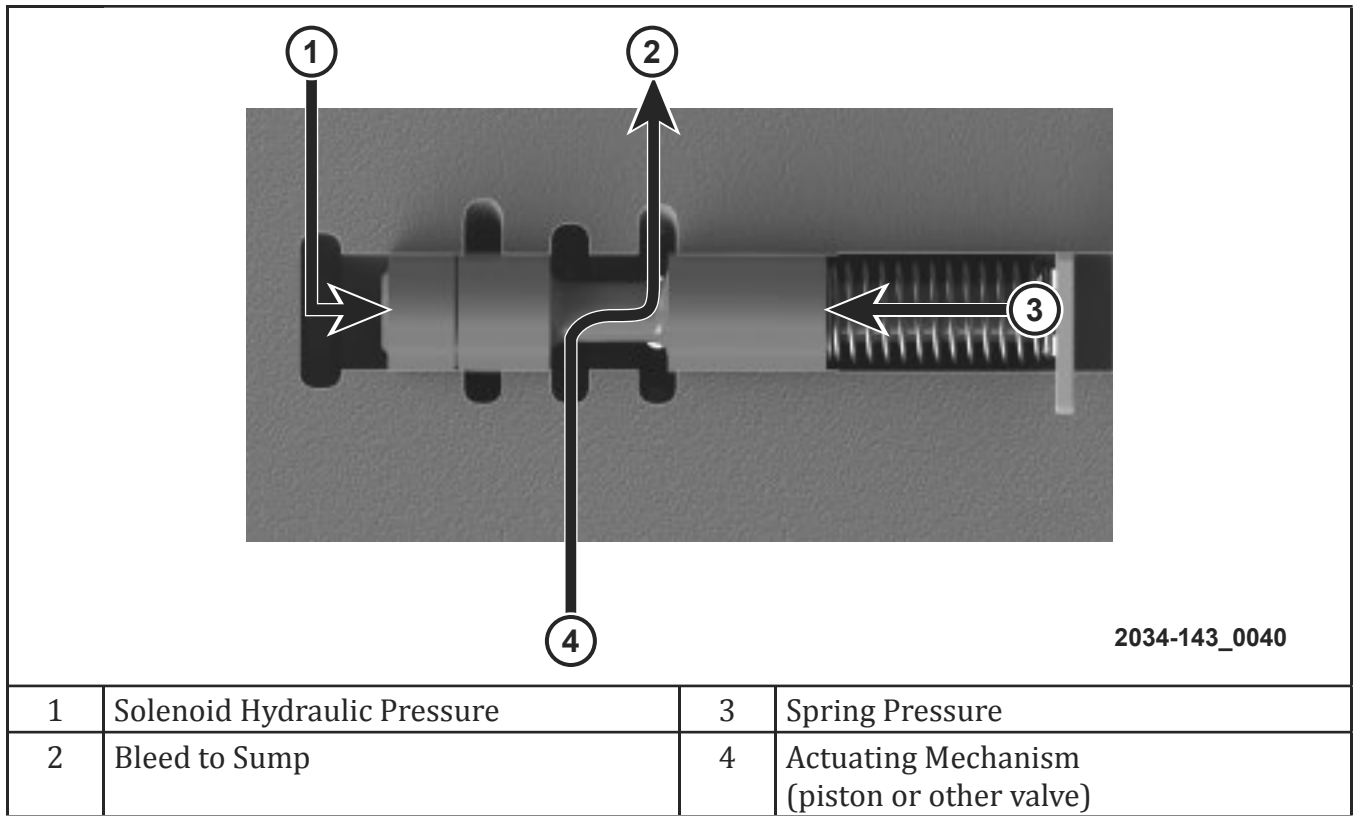

Figure 112 Balance Valve in the Fully Stroked Position

When the hydraulic force builds up enough force to overcome the spring force, the hydraulic force strokes the valve to the right, compressing the spring even more and redirecting the fluid up into the passage. When there is a loss of pressure due to the redirection of oil, the spring force closes the passage again.

Table 4 Domestic Hydraulic Schematic Legend











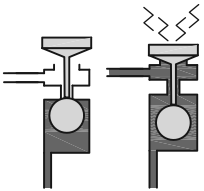
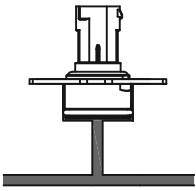
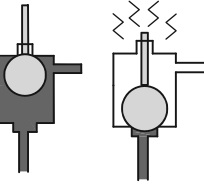
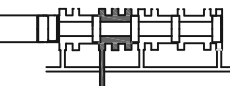
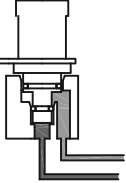
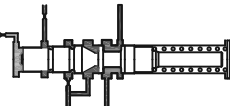
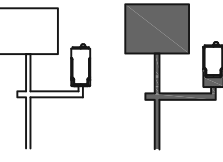
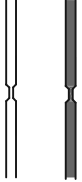
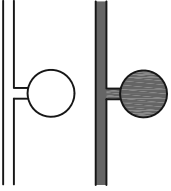
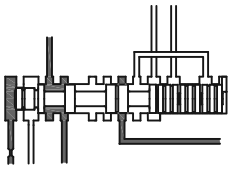
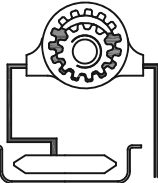
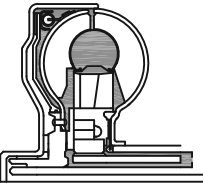
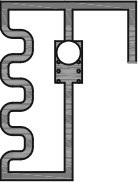
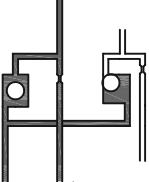
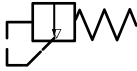





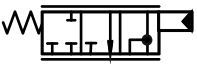

	<p>Normally-Vented Solenoid</p>		<p>Pressure Transducer</p>
	<p>Normally-Applied Solenoid</p>		<p>Manual Valve</p>
	<p>Variable Force Solenoid</p>		<p>Pressure Regulator Valve</p>
	<p>Clutch and Accumulator Circuit</p>		<p>Orifice</p>
	<p>Pressure Switches</p>		<p>Switch Valve</p>
	<p>Pump and Filter Assembly</p>		<p>Torque Converter</p>
	<p>Fluid Cooler and Bypass Valve</p>		<p>Check Ball Valves</p>

Table 5 ISO Hydraulic Schematic Legend

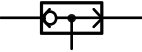
	Pressure Regulating Valve		Pump
	Hydraulic Piston		Sump Filter
	Hydraulically-controlled Directional Control Valve (2 Positions/3 Channels)		In-line Filter
	Spring-loaded Hydraulically-controlled Valve (3 Positions/3 Channels)		Fluid Cooler
	Spring-loaded Directional Control Valve (2 Positions/5 Channels)		Torque Converter
	Electrical Solenoid Valve (2 Positions/3 Channels)		Pressure Retention Valve (Spring-loaded Check Ball)
	Rocker Ball Valve (Shuttle Valve)		Return to Sump
	Check-ball-controlled Orifice		Accumulator
	Orifice		One-way Orifice

GLOSSARY

adaptive strategies	Dynamic control over shift operation based on driving conditions and driver input.
cavitation	The formation of cavities or bubbles in a fluid that is being pumped. This occurs when the fluid level is too low and the inlet pipe draws air into the pumping system. This can also occur when the fluid level is too high and contacts the rotating components of the gear train (think of beating an egg with a whisk).
contact point pressure	The pressure necessary to fill the B1 clutch piston to allow it to just touch the release point.
controlled slip	Regulated amount of slip on the B clutch in neutral idle control.
de-energized	An electrical solenoid is not being supplied any current.
detent	A device that holds a component into a position.
differential	A set of gears that allows the driving wheels to turn at different speeds.
double-stroke vane pump	A dual inlet and outlet chambered positive-displacement pump that consists of vanes mounted to a rotor that turns inside of a cavity.
electronic shifter	The electronic shifter system that uses sensors and bus communication instead of a traditional shift cable to control direction of movement.
electrostatic discharge	The human body, if electrically charged, but not properly grounded, discharges an electrostatic spark (this endangers electronic components).
facing	A friction material attached to at least one side of a clutch disc.
filled-for-life	Transmission fluid maintenance strategy stating: under normal operating conditions, it is not necessary to check the fluid level or change the fluid and filter.
freewheel	To turn without transferring torque.
gear	A wheel with teeth that engages another wheel with teeth.
gear ratio	The ratio of two meshed gears. To calculate gear ratio, divide the number of teeth on the driven gear by the number of teeth on the driving gear.
gear reduction	The input speed is higher than the output speed, increasing torque.
Hall-effect sensor	A transducer that varies its output voltage in response to a magnetic field.
helical gear	A gear with curved or spiral cut teeth.
holding clutch	A clutch that is splined to the case. When applied, the clutch causes a member of the gearset to stop rotating.
holding valve	Regulates the opening of the clutch valve to control shift feel.
molded lead frame	Molded plastic formed to the valve body that contains the internal harness and sensors.
multi-disc clutch pack	Type of clutch that has several driving members stacked with several driven members. Consisting of alternating steel and friction discs.

neutral idle control	A transmission strategy that disengages the transmission from engine torque when the vehicle is at a stop in a forward gear range.
planetary gearset	A gear system that consists of outer gears, or planet gears, revolving around a central, or sun gear, that also uses an outer gear or annulus, which meshes with the planet gears.
position valve	Supplies hydraulic pressure to the driving clutches and maintains pressure in the driving clutch circuits if an electrical failure occurs.
Ravigneaux gearset	A double planetary gearset using two sun gears with a long and short set of planetary pinion gears and one annulus gear.
rotating clutch	A clutch that is housed in a rotating drum or housing and provides input torque to the gear train.
sequential shifting	A pattern of gear shifts that maintain a sequential order (for example, 1st, 2nd, 3rd, 4th or 4th, 3rd, 2nd, 1st).
Simpson gearset	A planetary gearset consisting of two planetary gearsets that share a common sun gear.
spline	A raised area on a shaft that engages another component.
standpipe	A fluid plug that incorporates a length of pipe in the center that stands up inside the fluid reservoir, used for setting fluid level at specific temperature.
tapered roller bearing	A tapered or coned bearing using long, round rollers between two races.
thermal expansion	The expansion and contraction of metal components due to temperature changes.
torque	A turning or twisting force.
torsional vibrations	Angular vibration of an object, such as the components transmitting the torque, can generate non-smooth or alternating torques. The components in the transmission are not infinitely stiff, these alternating torques cause vibration around the axis of rotation.
transmission control module assembly (TCMA)	Includes the transmission control module, molded internal wire harness, and four input sensors.
variable force solenoid	A solenoid that is controlled by a pulse-width-modulated signal to control the amount of fluid pressure in a hydraulic circuit.
vortex flow	The swirling rotary flow of fluid between the torque converter impeller, stator, and turbine vanes.



FIAT CHRYSLER AUTOMOBILES

WORLDWIDE

The special service tools referred to herein are required for certain service operations. These special service tools or their equivalent, if not obtainable through a local source, are available through the following outlet:

Mopar Essential Tools and Service Equipment Snap-on Business Solutions

Telephone 1-855-298-2687

2801-80th Street Kenosha, WI 53143, U.S.A.

FAX 1-855-303-8985



ESSENTIAL TOOLS AND SERVICE EQUIPMENT

www.moparesentialtools.com



**WE ENCOURAGE
PROFESSIONALISM**



**THROUGH TECHNICIAN
CERTIFICATION**



**TRAINING PROGRAM
DEVELOPMENT DEPARTMENT**



No part of this publication may be reproduced, stored in a retrieval system or transmitted, in any form or by any means, electronic, mechanical, photocopying, recording, or otherwise, without the prior written permission of FCA US LLC.

Copyright© 2016 FCA US LLC